

WALL2_UP GATEVALVE

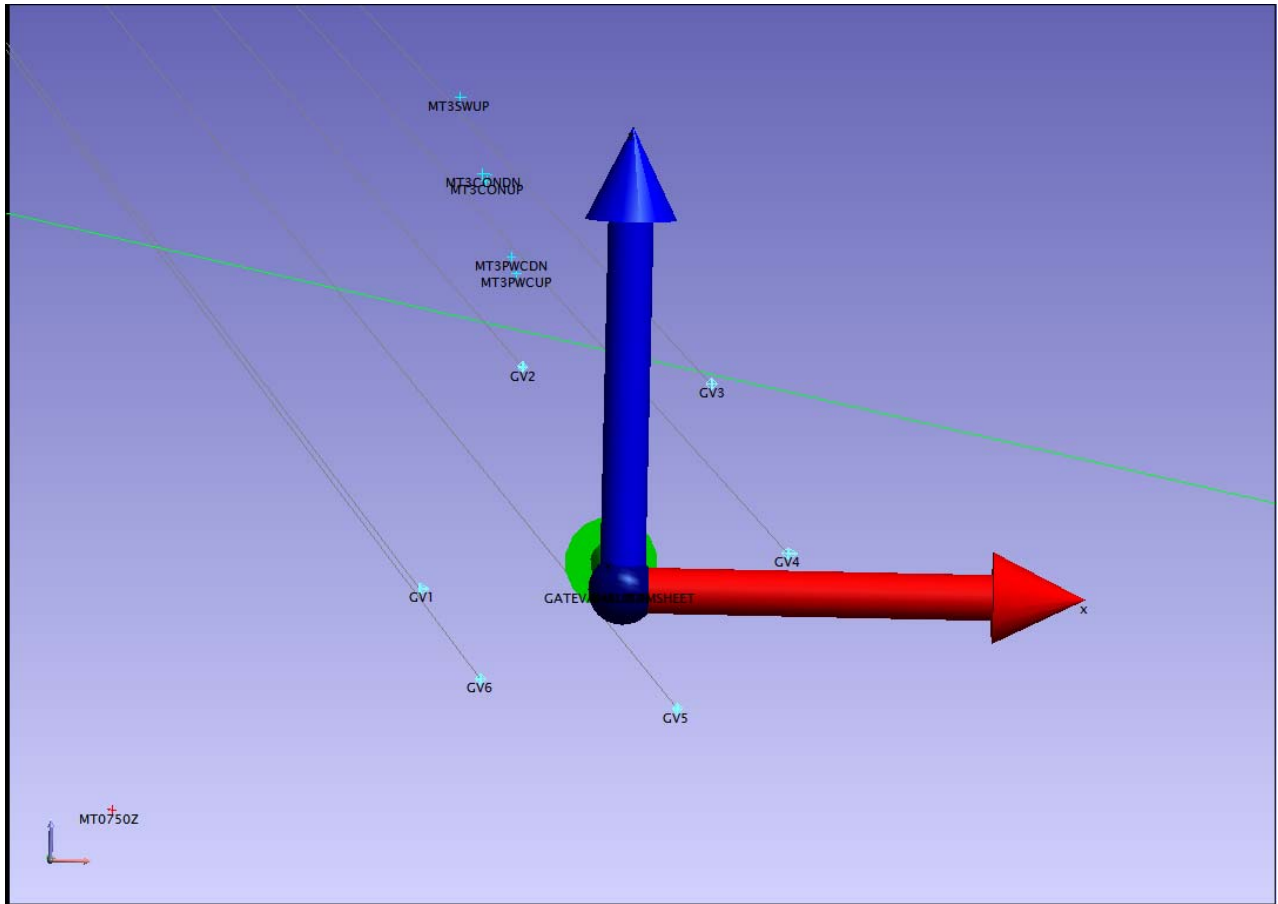

GATEVALVE ACTUALS AS-SET LOCAL						
Point Name	X	Y	Z	X	Y	Z
	[Inches]	[Inches]	[Inches]	[Metres]	[Metres]	[Metres]
GATEVALVE_CT OLD CONTROL	0.062	16.689	-0.142	0.00157	0.42390	-0.00361
GATEVALVE_CT NEW CONTROL	0.096	16.689	-0.135	0.00244	0.42390	-0.00343

14Feb07 Adjusted Control (FSCS_z).XYZ-Control (m).FSCS_z (ROTATED AROUND Z-AXIS CCW)

167356	-20.286	0.849	45.149	-20.331	0.846	45.142	-0.044	-0.002	-0.007	0.045
MT0750Z	-10.805	2.064	-5.130	-10.828	2.063	-5.140	-0.023	-0.000	-0.010	0.025
167358	-55.869	25.371	44.852	-55.913	25.369	44.845	-0.044	-0.002	-0.007	0.045
167355	-30.877	25.108	-18.652	-30.904	25.105	-18.661	-0.027	-0.003	-0.009	0.029
167357	19.971	24.241	45.213	19.927	24.238	45.204	-0.043	-0.003	-0.009	0.044
167366	-181.038	344.919	42.461	-181.081	344.919	42.450	-0.043	-0.000	-0.011	0.045

As-sets are shown relative to the Ideal Beam Sheet Position (Site coordinates for beam line: MTEST_r8.ces)

GATEVALVE ACTUALS AS-SET FSCS (Z)			
Point Name	X	Y	Z
	[Metres]	[Metres]	[Metres]
GATEVALVE_CT	30291.601254	32011.227116	227.155352

NOTES: Coordinates for the device are in the FSCS(z) coordinate system.

(+X - axis) is East, (+Y - axis) is North, (+Z - axis) is Vertical elevation

+ve Roll is cw rotation about the +Y-axis

+ve Pitch is the Vertical angle above the X-Y plane

+ve Yaw is the cw rotation about the +ve Z-axis

MT3PWC REFERENCE

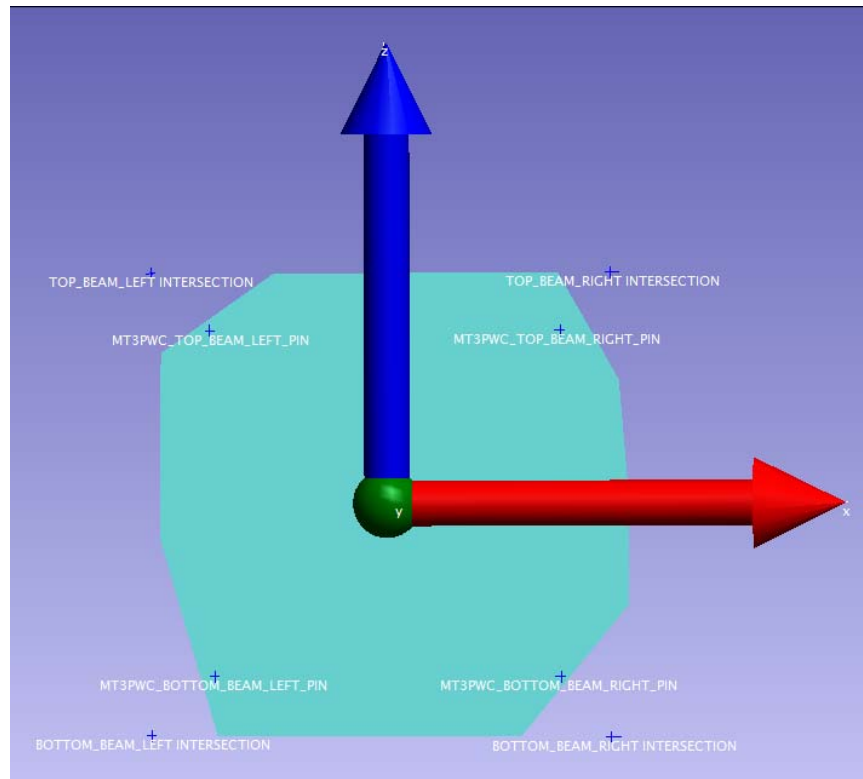



Reference is based on Best-fit Transformation to nominal pin values.

MT3PWC REFERENCE VALUES						
Point Name	X	Y	Z	X	Y	Z
	[Inches]	[Inches]	[Inches]	[Metres]	[Metres]	[Metres]
MT3PWC_TOP_BEAM_LEFT_PIN	-3.762	0.002	3.755	-0.09555	0.00006	0.09537
MT3PWC_BOTTOM_BEAM_LEFT_PIN	-3.739	-0.002	-3.743	-0.09498	-0.00006	-0.09507
MT3PWC_BOTTOM_BEAM_RIGHT_PIN	3.751	0.002	-3.758	0.09528	0.00006	-0.09544
MT3PWC_TOP_BEAM_RIGHT_PIN	3.750	-0.002	3.746	0.09525	-0.00006	0.09515
MT3PWC_CT_PINS	0.000	0.000	0.000	0.00000	0.00000	0.00000
MT3PWC_TOP_BEAM_LEFT INTERSECTION	-5.028	-0.999	4.995	-0.12770	-0.02536	0.12689
MT3PWC_BOTTOM_BEAM_LEFT INTERSECTION	-5.030	-1.005	-5.010	-0.12777	-0.02552	-0.12726
MT3PWC_BOTTOM_BEAM_RIGHT INTERSECTION	4.982	-0.994	-5.054	0.12654	-0.02525	-0.12836
MT3PWC_TOP_BEAM_RIGHT INTERSECTION	4.985	-0.993	4.997	0.12661	-0.02523	0.12691
MT3PWC_CT_INTERSECTION	-0.023	-0.998	-0.018	-0.00058	-0.02534	-0.00045

As-sets are shown relative to the Ideal Beam Sheet Position (Site coordinates for beam line: MTEST_r8.ces)

MT3PWC ACTUALS AS-SET LOCAL						
Point Name	X	Y	Z	X	Y	Z
	[Inches]	[Inches]	[Inches]	[Metres]	[Metres]	[Metres]
MT3PWC_TOP_BEAM_LEFT_PIN	-3.749	6.257	3.728	-0.09522	0.15893	0.09470
MT3PWC_BOTTOM_BEAM_LEFT_PIN	-3.717	6.231	-3.769	-0.09441	0.15826	-0.09573
MT3PWC_BOTTOM_BEAM_RIGHT_PIN	3.773	6.188	-3.774	0.09584	0.15718	-0.09587
MT3PWC_TOP_BEAM_RIGHT_PIN	3.763	6.205	3.729	0.09558	0.15760	0.09472
MT3PWC_CT_PINS	0.018	6.220	-0.021	0.00045	0.15799	-0.00054
MT3PWC_TOP_BEAM_LEFT INTERSECTION	-5.022	5.268	4.971	-0.12757	0.13380	0.12625
MT3PWC_BOTTOM_BEAM_LEFT INTERSECTION	-5.013	5.233	-5.035	-0.12732	0.13292	-0.12789
MT3PWC_BOTTOM_BEAM_RIGHT INTERSECTION	4.999	5.180	-5.066	0.12698	0.13157	-0.12867
MT3PWC_TOP_BEAM_RIGHT INTERSECTION	4.990	5.210	4.984	0.12674	0.13233	0.12660
MT3PWC_CT_INTERSECTION	-0.012	5.223	-0.036	-0.00029	0.13266	-0.00093

MT3PWC ACTUALS AS-SET FSCS(Z)			
Point Name	X	Y	Z
	[Metres]	[Metres]	[Metres]
MT3PWC_TOP_BEAM_LEFT_PIN	30291.040560	32013.216354	227.252323
MT3PWC_BOTTOM_BEAM_LEFT_PIN	30291.041520	32013.215778	227.061891
MT3PWC_BOTTOM_BEAM_RIGHT_PIN	30291.227113	32013.257632	227.061754
MT3PWC_TOP_BEAM_RIGHT_PIN	30291.226746	32013.258086	227.252342
MT3PWC_CT_PINS	30291.133985	32013.236963	227.157078
TOP_BEAM_LEFT INTERSECTION	30291.014708	32013.184592	227.283889
BOTTOM_BEAM_LEFT INTERSECTION	30291.015178	32013.183651	227.029750
BOTTOM_BEAM_RIGHT INTERSECTION	30291.263236	32013.239690	227.028961
TOP_BEAM_RIGHT INTERSECTION	30291.262793	32013.240511	227.284234
FIT TO POINTS	30291.138979	32013.212111	227.156708
	ROLL(mrad)	PITCH(mrad)	YAW(mrad)
	-0.97	-3.04	5.71

NOTES: Coordinates for the device are in the FSCS(z) coordinate system.

(+X - axis) is East, (+Y - axis) is North, (+Z - axis) is Vertical elevation

+ve Roll is cw rotation about the +Y-axis

+ve Pitch is the Vertical angle above the X-Y plane

+ve Yaw is the cw rotation about the +ve Z-axis

MT3CON

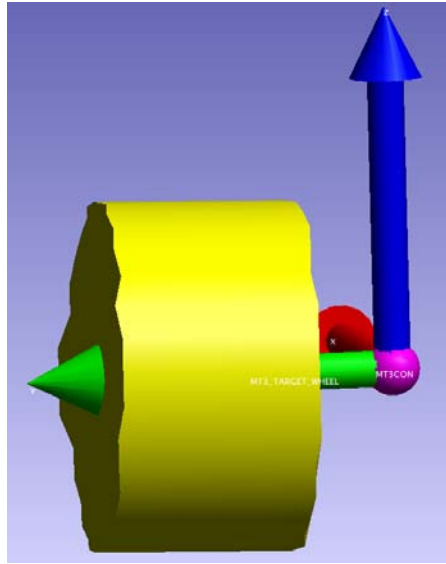

MT3CON REFERENCE VALUES						
Point Name	X	Y	Z	X	Y	Z
	[Inches]	[Inches]	[Inches]	[Metres]	[Metres]	[Metres]
MT3CON_CT	0.000	-0.000	-0.000	0.00000	-0.00000	-0.00000
MT3CON_UP	0.000	-1.638	0.000	0.00000	-0.04161	0.00000
MT3CON_DN	0.000	1.638	-0.000	0.00000	0.04160	-0.00000

As-sets are shown relative to the Ideal Beam Sheet Position (Site coordinates for beam line: MTEST_r8.ces)

MT3CON ACTUALS AS-SET LOCAL						
Point Name	X	Y	Z	X	Y	Z
	[Inches]	[Inches]	[Inches]	[Metres]	[Metres]	[Metres]
MT3CON_CT	0.041	3.267	0.002	0.00105	0.08298	0.00006
MT3CON_UP	0.037	1.630	-0.050	0.00093	0.04140	-0.00127
MT3CON_DN	0.046	4.904	0.055	0.00118	0.12456	0.00139

MT3CON ACTUALS AS-SET FSCS(Z)			
Point Name	X	Y	Z
	[Metres]	[Metres]	[Metres]
MT3CON_CT	30290.999095	32013.822403	227.157343
MT3CON_UP	30291.008346	32013.781866	227.156034
MT3CON_DN	30290.989843	32013.862941	227.158653
	ROLL(mrad)	PITCH(mrad)	YAW(mrad)
		32.0	2.95

NOTES: Coordinates for the device are in the FSCS(z) coordinate system.

(+X - axis) is East, (+Y - axis) is North, (+Z - axis) is Vertical elevation

+ve Roll is cw rotation about the +Y-axis

+ve Pitch is the Vertical angle above the X-Y plane

+ve Yaw is the cw rotation about the +ve Z-axis

MT3SW FRD#11451

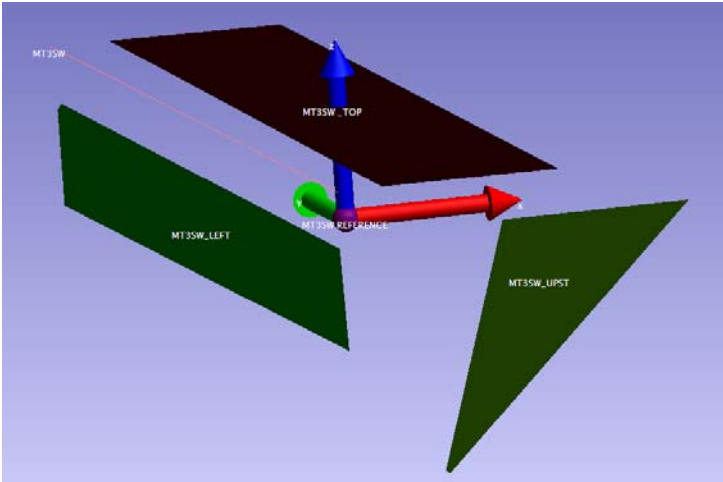

FRD 11451
H Correction 8"
V Correction 6.25"
Station Correction 60"



MT3SW REFERENCE VALUES						
Point Name	X	Y	Z	X	Y	Z
	[Inches]	[Inches]	[Inches]	[Metres]	[Metres]	[Metres]
MT3SW_UP	0.000	-60.000	0.000	0.00000	-1.52400	0.00000
MT3SW_CT	0.000	0.000	0.000	0.00000	0.00000	0.00000
MT3SW_DN	0.000	60.000	0.000	0.00000	1.52400	0.00000
MT3SW_TOP	0.000	0.000	6.250	0.00000	0.00000	0.15875
MT3SW_BEAM_RIGHT	8.000	0.000	0.000	0.20320	0.00000	0.00000

As-sets are shown relative to the Ideal Beam Sheet Position (Site coordinates for beam line: MTEST_r8.ces)

MT3SW ACTUALS AS-SET LOCAL						
Point Name	X	Y	Z	X	Y	Z
	[Inches]	[Inches]	[Inches]	[Metres]	[Metres]	[Metres]
MT3SW_UP	-0.014	-0.143	0.006	-0.00036	-0.00363	0.00015
MT3SW_CT	-0.005	59.857	0.001	-0.00013	1.52037	0.00003
MT3SW_DN	0.003	119.857	-0.003	0.00008	3.04437	-0.00008
	ROLL(mrad)	PITCH(mrad)	YAW(mrad)			
	0.78	-0.08	0.14			

MT3SW ACTUALS AS-SET FSCS (Z)			
Point Name	X	Y	Z
	[Metres]	[Metres]	[Metres]
MT3SW_UP	30290.877629	32014.340892	227.157141
MT3SW_CT	30290.534150	32015.825680	227.156159
MT3SW_DN	30290.190670	32017.310469	227.155177
	ROLL(mrad)	PITCH(mrad)	YAW(mrad)
	0.78	-0.08	0.14

NOTES: Coordinates for the device are in the FSCS(z) coordinate system.

(+X - axis) is East, (+Y - axis) is North, (+Z - axis) is Vertical elevation

+ve Roll is cw rotation about the +Y-axis

+ve Pitch is the Vertical angle above the X-Y plane

+ve Yaw is the cw rotation about the +ve Z-axis

MT3BS AS-SET USING PLANES

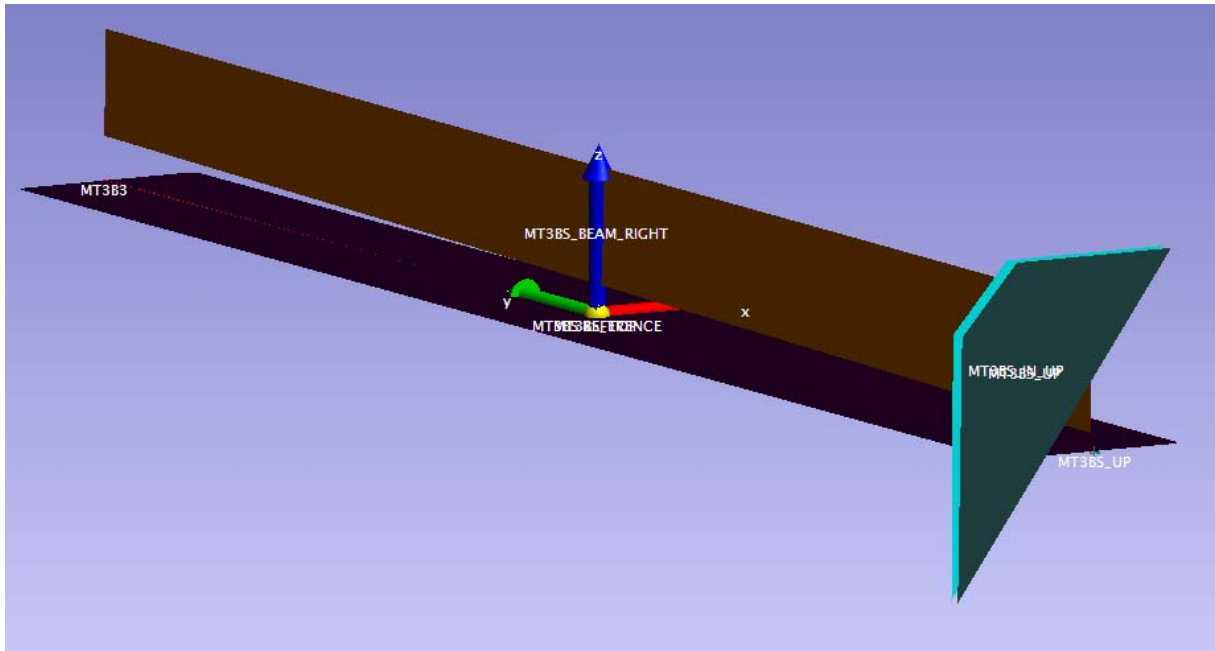



FRD# N/A
 H CORR. 7.0"
 V CORR. 11.0"
 STA CORR. 54.125"

MT3BS REFERENCE VALUES						
Values to large flanges						
Point Name	X	Y	Z	X	Y	Z
	[Inches]	[Inches]	[Inches]	[Metres]	[Metres]	[Metres]
MT3BS_TOP	0.000	0.000	11.000	0.00000	0.00000	0.27940
MT3BS_BEAM_RIGHT	7.062	0.000	0.000	0.17938	0.00000	0.00000
MT3BS_UP	0.000	-55.188	0.000	0.00000	-1.40178	0.00000
MT3BS_CT	0.000	0.000	0.000	0.00000	0.00000	0.00000
MT3BS_DN	0.000	55.188	0.000	0.00000	1.40178	0.00000

As-sets are shown relative to the Ideal Beam Sheet Position (Site coordinates for beam line: MTEST_r8.ces)

MT3BS ACTUALS AS-SET LOCAL						
Point Name	X	Y	Z	X	Y	Z
	[Inches]	[Inches]	[Inches]	[Metres]	[Metres]	[Metres]
MT3BS_UP	-0.031	-0.087	0.527	-0.00079	-0.00221	0.01339
MT3BS_CT	0.055	55.100	0.637	0.00140	1.39954	0.01618
MT3BS_DN	0.140	110.287	0.748	0.00356	2.80130	0.01900

NOTE: THE VERTICAL VALUES APPEAR RATHER LARGE. IT WAS AN ASFOUND SO THE NUMBERS MAY BE REAL. REALLY SHOULD BE LOOKED AT AGAIN.

MT3BS ACTUALS AS-SET FSCS(Z)			
Point Name	X	Y	Z
	[Metres]	[Metres]	[Metres]
MT3BS_UP	30290.078891	32017.789534	227.168364
MT3BS_CT	30289.764884	32019.155660	227.170379
MT3BS_DN	30289.450874	32020.521798	227.172393
	ROLL(mrad)	PITCH(mrad)	YAW(mrad)
	-1.50	2.00	1.54

NOTES: Coordinates for the device are in the FSCS(z) coordinate system.

(+X - axis) is East, (+Y - axis) is North, (+Z - axis) is Vertical elevation

+ve Roll is cw rotation about the +Y-axis

+ve Pitch is the Vertical angle above the X-Y plane

+ve Yaw is the cw rotation about the +ve Z-axis

MT3Q3 FRD#20126

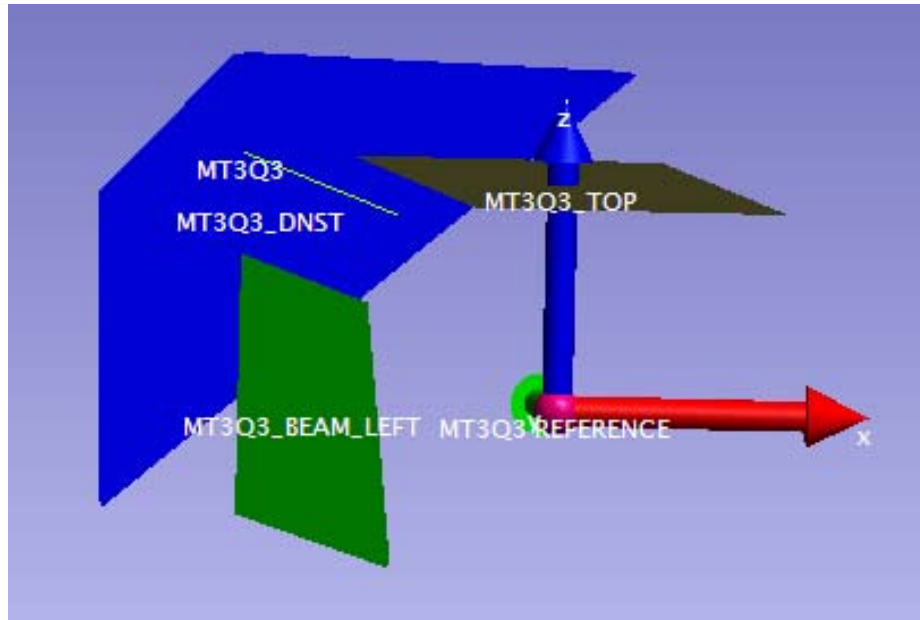

FRD#20126
H CORR. 8.25"
V CORR. 7.25"
STA CORR. 60"

MT3Q3 REFERENCE VALUES						
Point Name	X	Y	Z	X	Y	Z
	[Inches]	[Inches]	[Inches]	[Metres]	[Metres]	[Metres]
MT3Q3_UP	0.000	-60.000	0.000	0.00000	-1.52400	0.00000
MT3Q3_CT	0.000	0.000	0.000	0.00000	0.00000	0.00000
MT3Q3_DN	0.000	60.000	0.000	0.00000	1.52400	0.00000
MT3Q3_TOP	0.000	0.000	7.250	0.00000	0.00000	0.18415
MT3Q3_BEAM_RIGHT	8.250	0.000	0.000	0.20955	0.00000	0.00000

As-sets are shown relative to the Ideal Beam Sheet Position (Site coordinates for beam line: MTEST_r8.ces)

MT3Q3 ACTUALS AS-SET LOCAL						
Point Name	X	Y	Z	X	Y	Z
	[Inches]	[Inches]	[Inches]	[Metres]	[Metres]	[Metres]
MT3Q3_UP	0.006	-0.008	-0.001	0.00015	-0.00020	-0.00003
MT3Q3_CT	0.001	59.992	-0.005	0.00003	1.52380	-0.00013
MT3Q3_DN	-0.004	119.992	-0.009	-0.00010	3.04780	-0.00023
	ROLL(mrad)	PITCH(mrad)	YAW(mrad)			
	-0.02	-0.06	-0.09			

MT3Q3 ACTUALS AS-SET FSCS(Z)			
Point Name	X	Y	Z
	[Metres]	[Metres]	[Metres]
MT3Q3_UP	30289.344354	32020.966881	227.153107
MT3Q3_CT	30289.000538	32022.451590	227.152151
MT3Q3_DN	30288.656721	32023.936300	227.151196
	ROLL(mrad)	PITCH(mrad)	YAW(mrad)
	-0.02	-0.06	-0.09

NOTES: Coordinates for the device are in the FSCS(z) coordinate system.

(+X - axis) is East, (+Y - axis) is North, (+Z - axis) is Vertical elevation

+ve Roll is cw rotation about the +Y-axis

+ve Pitch is the Vertical angle above the X-Y plane

+ve Yaw is the cw rotation about the +ve Z-axis

MT3Q4 FRD#20124

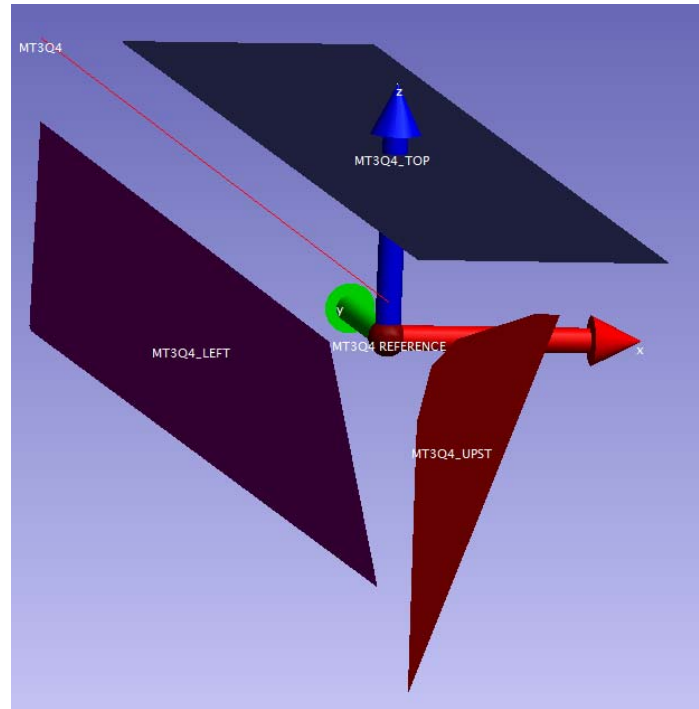

FRD# 20124
H CORR. 8.25"
V CORR. 7.25"
STA CORR. 60"

MT3Q4 REFERENCE VALUES						
Point Name	X	Y	Z	X	Y	Z
	[Inches]	[Inches]	[Inches]	[Metres]	[Metres]	[Metres]
MT3Q4_UP	0.000	-60.000	0.000	0.00000	-1.52400	0.00000
MT3Q4_CT	0.000	0.000	0.000	0.00000	0.00000	0.00000
MT3Q4_DN	0.000	60.000	0.000	0.00000	1.52400	0.00000
MT3Q4_TOP	0.000	0.000	7.250	0.00000	0.00000	0.18415
MT3Q4_BEAM_LEFT	-8.250	0.000	0.000	-0.20955	0.00000	0.00000

As-sets are shown relative to the Ideal Beam Sheet Position (Site coordinates for beam line: MTEST_r8.ces)

MT3Q4 ACTUALS AS-SET LOCAL						
Point Name	X	Y	Z	X	Y	Z
	[Inches]	[Inches]	[Inches]	[Metres]	[Metres]	[Metres]
MT3Q4_UP	0.008	-0.365	0.014	0.00020	-0.00927	0.00036
MT3Q4_CT	0.000	59.634	-0.000	0.00000	1.51471	0.00000
MT3Q4_DN	-0.007	119.634	-0.015	-0.00018	3.03871	-0.00038
	ROLL(mrad)	PITCH(mrad)	YAW(mrad)			
	0.26	-0.24	-0.12			

MT3Q4 ACTUALS AS-SET FSCS(Z)			
Point Name	X	Y	Z
	[Metres]	[Metres]	[Metres]
MT3Q4_UP	30288.555958	32024.372968	227.151522
MT3Q4_CT	30288.212086	32025.857656	227.150295
MT3Q4_DN	30287.868212	32027.342353	227.149068
	ROLL(mrad)	PITCH(mrad)	YAW(mrad)
	0.26	-0.24	-0.12

NOTES: Coordinates for the device are in the FSCS(z) coordinate system.

(+X - axis) is East, (+Y - axis) is North, (+Z - axis) is Vertical elevation

+ve Roll is cw rotation about the +Y-axis

+ve Pitch is the Vertical angle above the X-Y plane

+ve Yaw is the cw rotation about the +ve Z-axis

MT3CN2



MT3CN2 LOOKING DOWNSTREAM

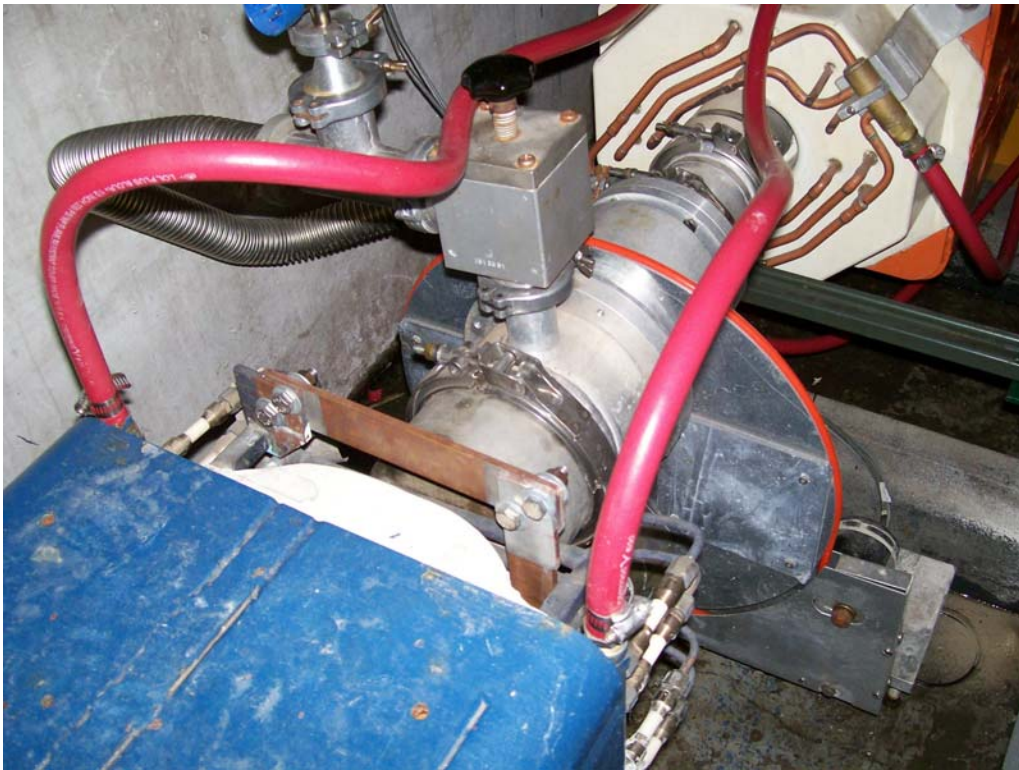

MT3CN2 LOOKING UPSTREAM

NOTE: This was never surveyed in place.

MT3W FRD#10997

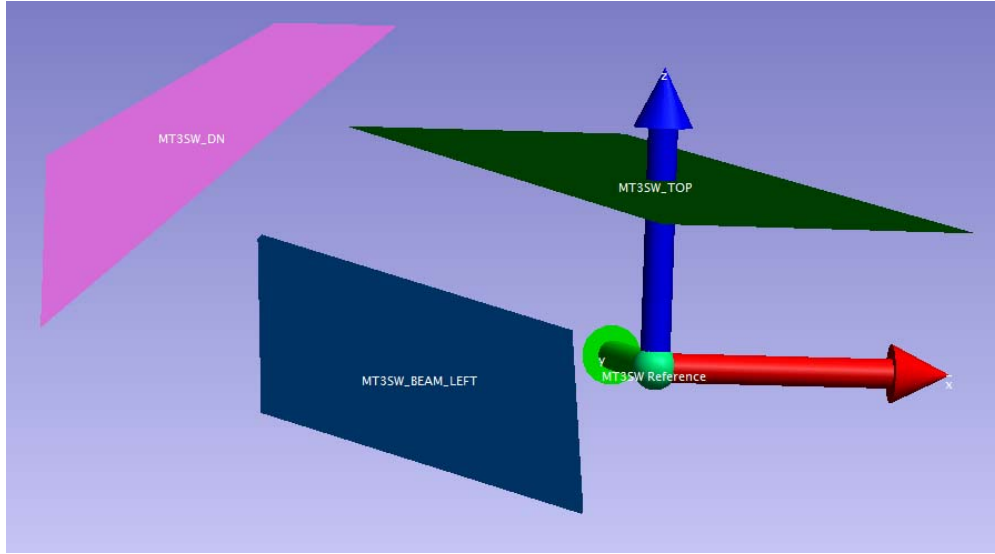

HORZ= 8.0"
VERT = 6.25"
FRD # 10097
STA COR = 60.0"

MT3W REFERENCE VALUES						
Point Name	X	Y	Z	X	Y	Z
	[Inches]	[Inches]	[Inches]	[Metres]	[Metres]	[Metres]
MT3W_CT	0.000	0.000	0.000	0.00000	0.00000	0.00000
MT3W_UP	0.000	-60.000	0.000	0.00000	-1.52400	0.00000
MT3W_DN	0.000	60.000	0.000	0.00000	1.52400	0.00000
MT3W_TOP	0.000	0.000	6.250	0.00000	0.00000	0.15874
MT3W_BEAM_LEFT	-8.000	0.000	0.000	-0.20321	0.00000	0.00000

As-sets are shown relative to the Ideal Beam Sheet Position (Site coordinates for beam line: MTEST_r8.ces)

MT3W ACTUALS AS-SET LOCAL						
Point Name	X	Y	Z	X	Y	Z
	[Inches]	[Inches]	[Inches]	[Metres]	[Metres]	[Metres]
MT3W_UP	-0.003	-0.088	0.002	-0.00007	-0.00223	0.00005
MT3W_CT	0.007	59.912	0.004	0.00018	1.52177	0.00010
MT3W_DN	0.017	119.912	0.006	0.00043	3.04577	0.00016
	ROLL(mrad)	PITCH(mrad)	YAW(mrad)			
	-0.07	0.00	0.17			

MT3W ACTUALS AS-SET FSCS(Z)			
Point Name	X	Y	Z
	[Metres]	[Metres]	[Metres]
MT3W_UP	30287.688449	32028.119461	227.149037
MT3W_CT	30287.340178	32029.603133	227.148233
MT3W_DN	30286.991907	32031.086805	227.147429
	ROLL(mrad)	PITCH(mrad)	YAW(mrad)
	-0.07	0.00	0.17

NOTES: Coordinates for the device are in the FSCS(z) coordinate system.

(+X - axis) is East, (+Y - axis) is North, (+Z - axis) is Vertical elevation

+ve Roll is cw rotation about the +Y-axis

+ve Pitch is the Vertical angle above the X-Y plane

+ve Yaw is the cw rotation about the +ve Z-axis

MT3U1 FRD#11168

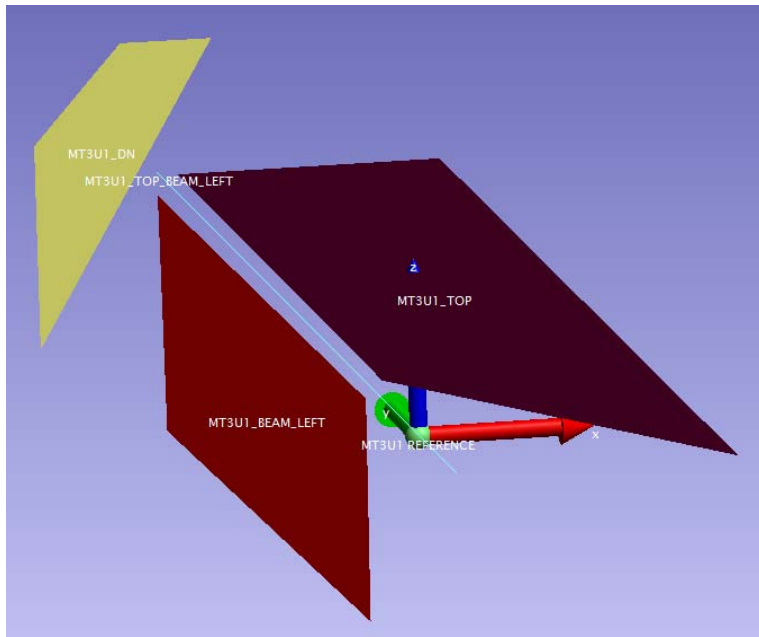

HORZ = 8.25"

VERT = 9.25"

STA COR = 60"

FRD 11168

NOTE: Vert Component

HORZ Adjustments inaccessible therefore left off line

MT3U1 REFERENCE VALUES						
Point Name	X	Y	Z	X	Y	Z
	[Inches]	[Inches]	[Inches]	[Metres]	[Metres]	[Metres]
MT3U1_UP	0.000	-60.000	0.000	0.00000	1.52399	0.00000
MT3U1_CT	0.000	0.000	0.000	0.00000	0.00000	0.00000
MT3U1_DN	0.000	60.000	0.000	0.00000	-1.52399	0.00000
MT3U1_TOP	0.000	0.000	9.250	0.00000	0.00000	0.23495
MT3U1_BEAM_LEFT	-8.250	0.000	0.000	-0.20956	0.00000	0.00000

As-sets are shown relative to the Ideal Beam Sheet Position (Site coordinates for beam line: MTEST_r8.ces)

MT3U1 ACTUALS AS-SET LOCAL						
Point Name	X	Y	Z	X	Y	Z
	[Inches]	[Inches]	[Inches]	[Metres]	[Metres]	[Metres]
MT3U1_UP	0.068	-0.680	-0.002	0.00172	-0.01729	-0.00004
MT3U1_CT	0.055	59.320	0.005	0.00141	1.50672	0.00014
MT3U1_DN	0.043	119.320	0.012	0.00110	3.03072	0.00031
	ROLL(mrad)	PITCH(mrad)	YAW(mrad)			
	1.35	0.11	-0.20			

HORIZONTAL: Adjustments inaccessible therefore left off line
STATIONING: This value seems rather large – should be re-checked.

MT3U1 ACTUALS AS-SET FSCS(Z)			
Point Name	X	Y	Z
	[Metres]	[Metres]	[Metres]
MT3U1_UP	30286.846497	32031.702514	227.146858
MT3U1_CT	30286.492862	32033.184917	227.147356
MT3U1_DN	30286.139226	32034.667320	227.147854
	ROLL(mrad)	PITCH(mrad)	YAW(mrad)
	1.35	0.11	-0.20

NOTES: Coordinates for the device are in the FSCS(z) coordinate system.
 (+X - axis) is East, (+Y - axis) is North, (+Z - axis) is Vertical elevation

- +ve Roll is cw rotation about the +Y-axis
- +ve Pitch is the Vertical angle above the X-Y plane
- +ve Yaw is the cw rotation about the +ve Z-axis

MT3U2 FRD#11166



BEAMPIPE BETWEEN MT3U1 AND MT3U2 – LOOKING UPSTREAM

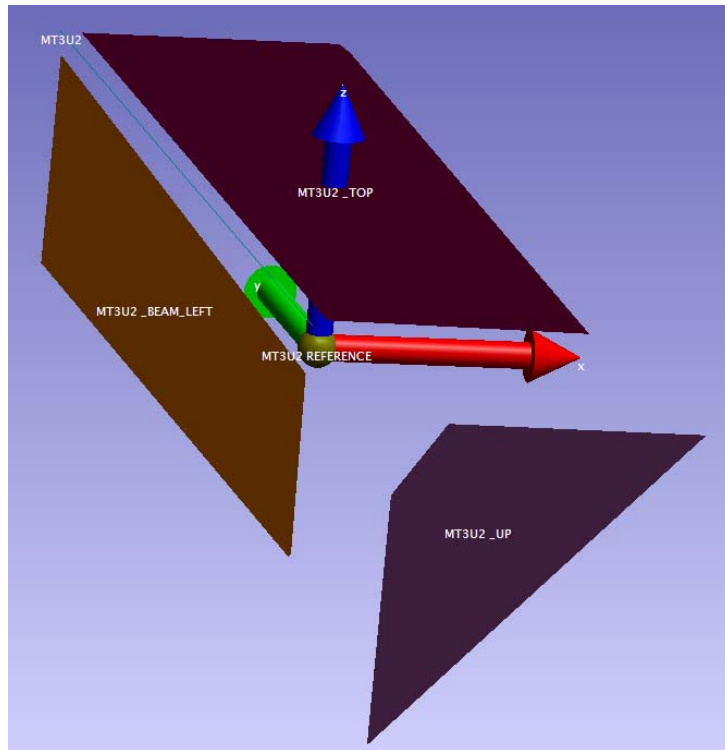



MT3U2 – LOOKING DOWNSTREAM



MT3U2 – LOOKING UPSTREAM

HORZ = 8.25"

VERT = 9.25"

STA COR = 60"

FRD 11166

NOTE: Vert Component

HORZ Adjustments inaccessible therefore left off line

MT3U2 REFERENCE VALUES						
Point Name	X	Y	Z	X	Y	Z
	[Inches]	[Inches]	[Inches]	[Metres]	[Metres]	[Metres]
MT3U2_UP	0.000	-60.000	0.000	0.00000	1.52399	0.00000
MT3U2_CT	0.000	0.000	0.000	0.00000	0.00000	0.00000
MT3U2_DN	0.000	60.000	0.000	0.00000	-1.52399	0.00000
MT3U2_TOP	0.000	0.000	9.250	0.00000	0.00000	0.23495
MT3U2_BEAM_LEFT	-8.250	0.000	0.000	-0.20956	0.00000	0.00000

As-sets are shown relative to the Ideal Beam Sheet Position (Site coordinates for beam line: MTEST_r8.ces)

MT3U2 ACTUALS AS-SET LOCAL						
Point Name	X	Y	Z	X	Y	Z
	[Inches]	[Inches]	[Inches]	[Metres]	[Metres]	[Metres]
MT3U2_UP	-0.031	-0.087	-0.012	-0.00079	-0.00221	-0.00030
MT3U2_CT	-0.008	59.913	-0.001	-0.00020	1.52179	-0.00003
MT3U2_DN	0.015	119.913	0.010	0.00038	3.04580	0.00025
	ROLL(mrad)	PITCH(mrad)	YAW(mrad)			
	3.15	0.18	0.38			

MT3U2 ACTUALS AS-SET FSCS(Z)			
Point Name	X	Y	Z
	[Metres]	[Metres]	[Metres]
MT3U2_UP	30284.579247	32041.204444	227.153874
MT3U2_CT	30284.226483	32042.687043	227.156836
MT3U2_DN	30283.873717	32044.169650	227.159799
	ROLL(mrad)	PITCH(mrad)	YAW(mrad)
	3.15	0.18	0.38

NOTES: Coordinates for the device are in the FSCS(z) coordinate system.

(+X - axis) is East, (+Y - axis) is North, (+Z - axis) is Vertical elevation

+ve Roll is cw rotation about the +Y-axis

+ve Pitch is the Vertical angle above the X-Y plane

+ve Yaw is the cw rotation about the +ve Z-axis

MT4PWC REFERENCE

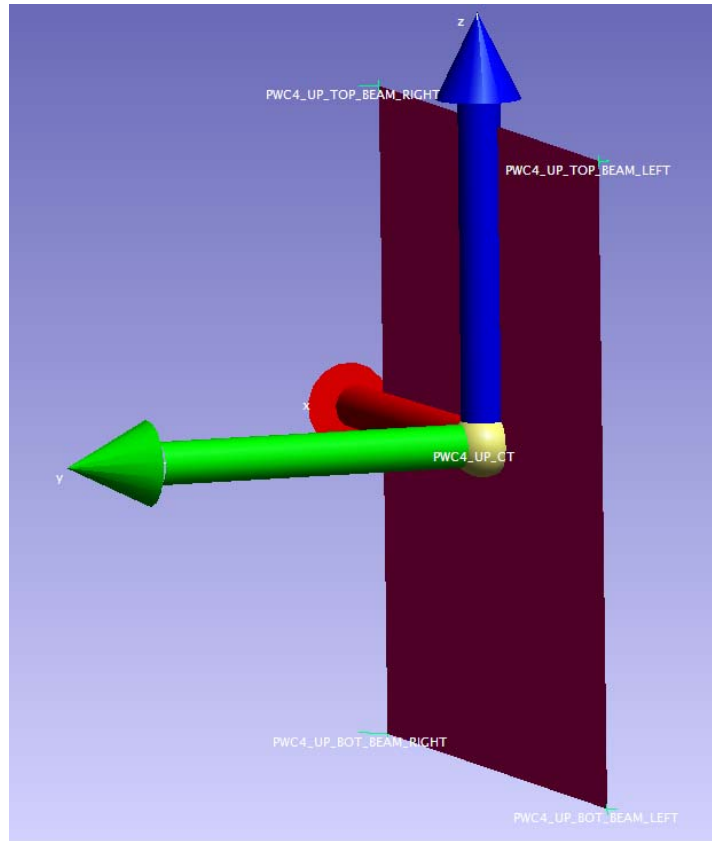

MT4PWC

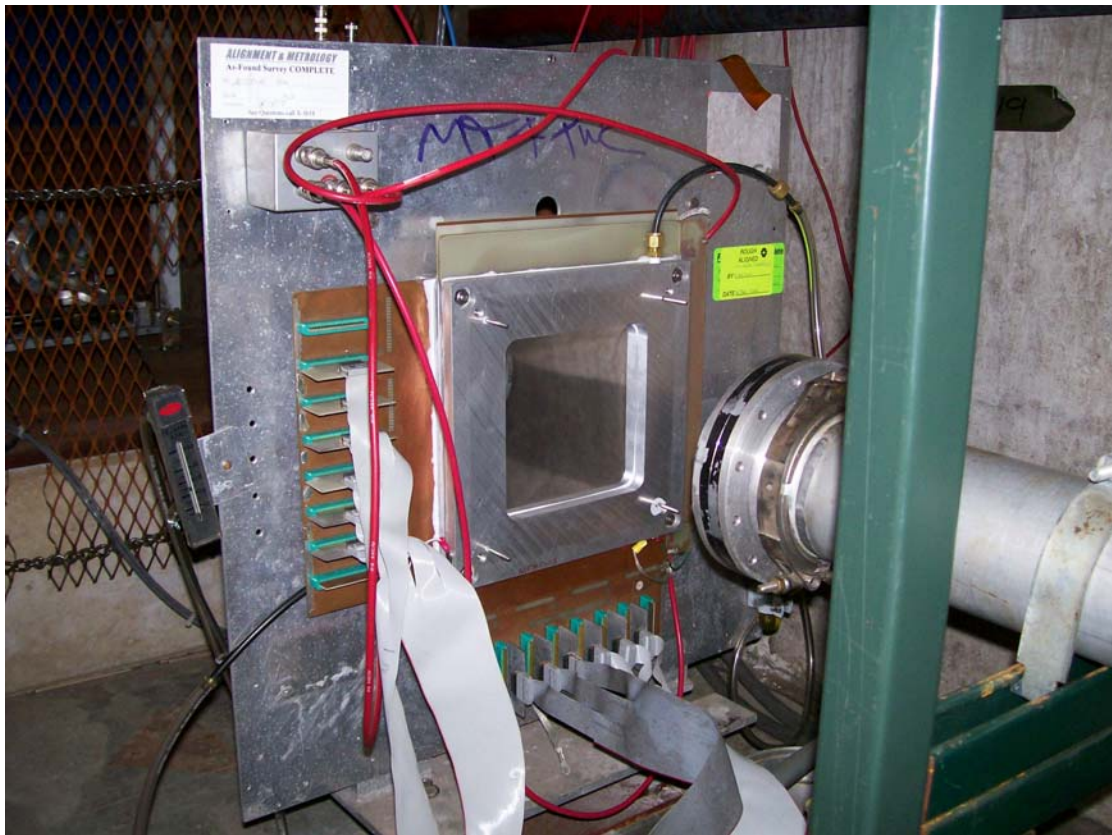

MT4PWC LOOKING DOWNSTREAM

Reference is based on Best-fit Transformation to nominal pin values.

MT4PWC REFERENCE VALUES						
Point Name	X	Y	Z	X	Y	Z
	[Inches]	[Inches]	[Inches]	[Metres]	[Metres]	[Metres]
MT4PWC_TOP_BEAM_LEFT_PIN	-3.750	-0.001	3.748	-0.09525	-0.00003	0.09520
MT4PWC_BOTTOM_BEAM_LEFT_PIN	-3.746	0.001	-3.747	-0.09515	0.00003	-0.09517
MT4PWC_BOTTOM_BEAM_RIGHT_PIN	3.747	-0.001	-3.749	0.09517	-0.00003	-0.09522
MT4PWC_TOP_BEAM_RIGHT_PIN	3.748	0.001	3.748	0.00000	0.00000	0.00000
MT4PWC_CT_PINS	0.000	-0.000	0.000	-0.09525	-0.00003	0.09520

As-sets are shown relative to the Ideal Beam Sheet Position (Site coordinates for beam line: MTEST_r8.ces)

MT4PWC ACTUALS AS-SET LOCAL						
Point Name	X	Y	Z	X	Y	Z
	[Inches]	[Inches]	[Inches]	[Metres]	[Metres]	[Metres]
MT4PWC_TOP_BEAM_LEFT_PIN	-3.739	-0.102	3.681	-0.09497	-0.00259	0.09350
MT4PWC_BOTTOM_BEAM_LEFT_PIN	-3.692	-0.123	-3.819	-0.09378	-0.00312	-0.09700
MT4PWC_BOTTOM_BEAM_RIGHT_PIN	3.808	-0.145	-3.773	0.09672	-0.00368	-0.09583
MT4PWC_TOP_BEAM_RIGHT_PIN	3.761	-0.124	3.727	0.09553	-0.00315	0.09467
MT4PWC_CT_PINS	0.034	-0.123	-0.046	0.00086	-0.00312	-0.00117

MT4PWC ACTUALS AS-SET FSCS(Z)			
Point Name	X	Y	Z
	[Metres]	[Metres]	[Metres]
MT4PWC_TOP_BEAM_LEFT_PIN	30283.491375	32045.362556	227.256218
MT4PWC_BOTTOM_BEAM_LEFT_PIN	30283.492542	32045.362783	227.065722
MT4PWC_BOTTOM_BEAM_RIGHT_PIN	30283.677970	32045.406431	227.066909
MT4PWC_TOP_BEAM_RIGHT_PIN	30283.676804	32045.406203	227.257406
MT4PWC_CT_PINS	30283.584673	32045.384493	227.161564
	ROLL(mrad)	PITCH(mrad)	YAW(mrad)
	6.24	-2.80	0.02

NOTES: Coordinates for the device are in the FSCS(z) coordinate system.

(+X - axis) is East, (+Y - axis) is North, (+Z - axis) is Vertical elevation

+ve Roll is cw rotation about the +Y-axis

+ve Pitch is the Vertical angle above the X-Y plane

+ve Yaw is the cw rotation about the +ve Z-axis

MT4TGT



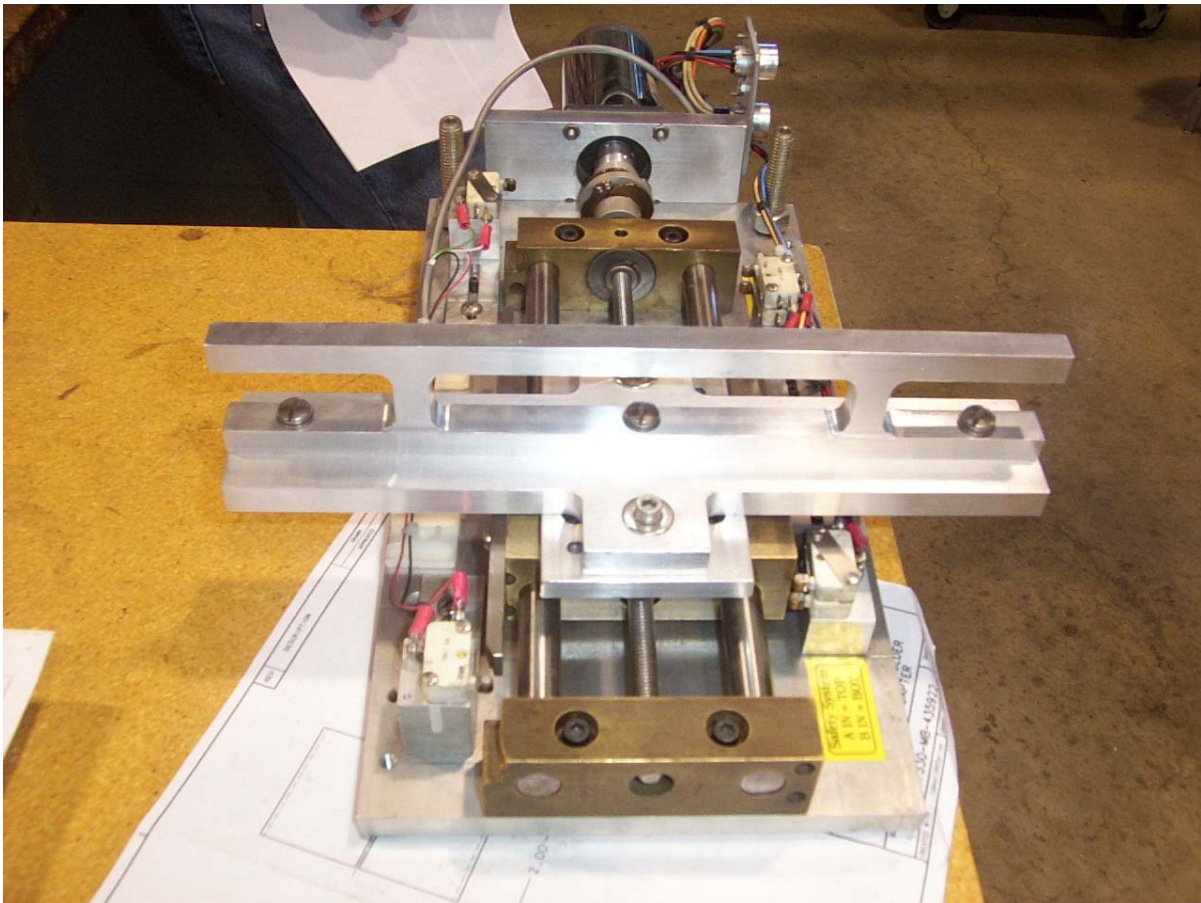
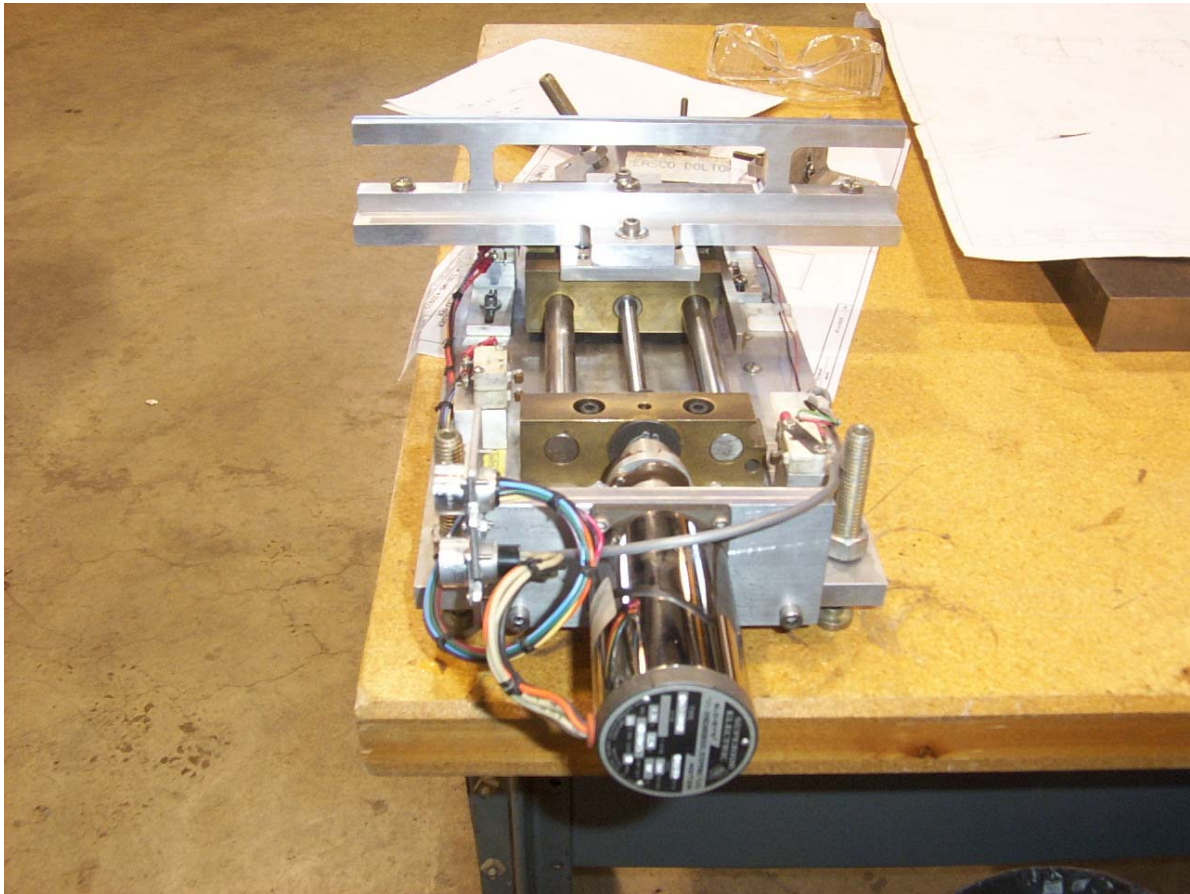

Target = 0.5 X 0.5 inches X 12.0 inch length

MT4TGT REFERENCE VALUES						
Point Name	X	Y	Z	X	Y	Z
	[Inches]	[Inches]	[Inches]	[Metres]	[Metres]	[Metres]
MT4TGT_UP	0.000	-6.000	0.000	0.00000	-0.15240	0.00000
MT4TGT_CT	0.000	0.000	0.000	0.00000	0.00000	0.00000
MT4TGT_DN	0.000	6.000	0.000	0.00000	0.15240	0.00000
MT4TGT_BEAM_LEFT	-0.250	0.000	0.000	-0.00635	0.00000	0.00000
MT4TGT_BEAM_RIGHT	0.250	0.000	0.000	0.00635	0.00000	0.00000
MT4TGT_TOP	0.000	0.000	0.250	0.00000	0.00000	0.00635

As-sets are shown relative to the Ideal Beam Sheet Position (Site coordinates for beam line: MTEST_r8.ces)

MT4TGT ACTUALS AS-SET LOCAL						
Point Name	X	Y	Z	X	Y	Z
	[Inches]	[Inches]	[Inches]	[Metres]	[Metres]	[Metres]
MT4TGT_UP	0.088	26.829	-0.001	0.00224	0.68146	-0.00003
MT4TGT_CT	0.089	32.829	0.003	0.00226	0.83386	0.00008
MT4TGT_DN	0.090	38.829	0.006	0.00229	0.98626	0.00015

MT4TGT ACTUALS AS-SET FSCS (Z)			
Point Name	X	Y	Z
	[Metres]	[Metres]	[Metres]
MT4TGT_UP	30283.300367	32046.583205	227.165845
MT4TGT_CT	30283.265066	32046.731459	227.166313
MT4TGT_DN	30283.229764	32046.879714	227.166782
	ROLL(mrad)	PITCH(mrad)	YAW(mrad)
	N/A	0.5	0.25

NOTES: Coordinates for the device are in the FSCS(z) coordinate system.

(+X - axis) is East, (+Y - axis) is North, (+Z - axis) is Vertical elevation

+ve Roll is cw rotation about the +Y-axis

+ve Pitch is the Vertical angle above the X-Y plane

+ve Yaw is the cw rotation about the +ve Z-axis

MTABS



MTABS UPSTREAM (Looking Downstream)

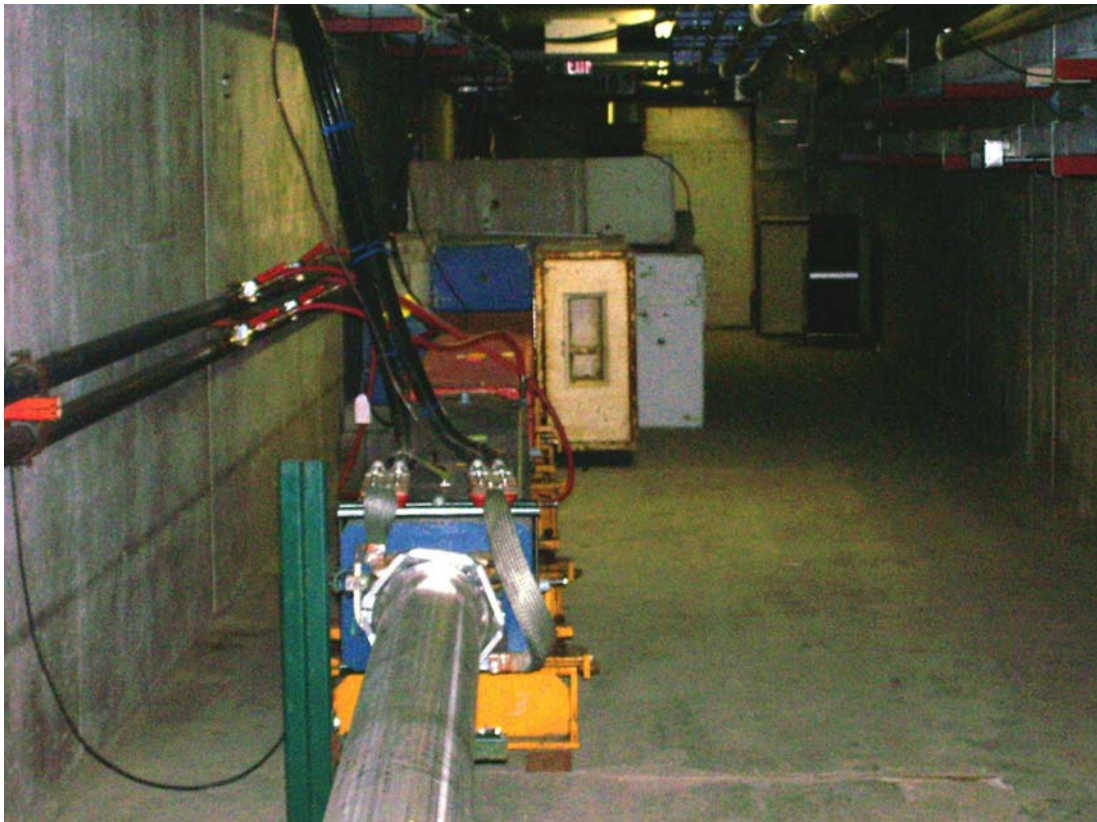

MTABS DOWNSTREAM (Looking Upstream)



MTABS DOWNSTREAM (Looking Upstream)

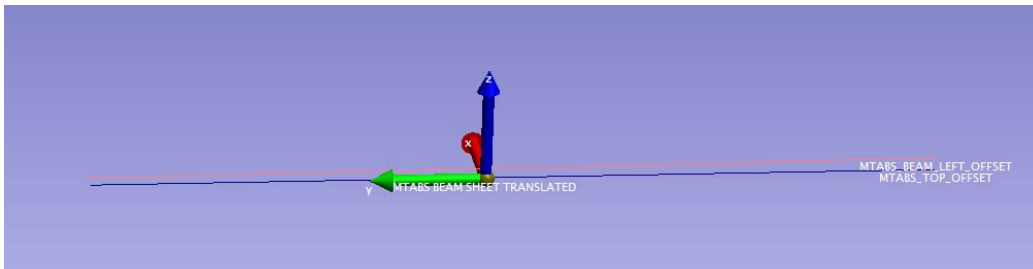

MTABS DOWNSTREAM

1.017 IN DIAMETER
 SHOT WITH 8 INCHES OF STICK
 14-Feb-07 observed Downstream End ONLY (MTABS DNST PIPE.xit)

Assumed to be shot with 28" of stick
 7002_20nov06.xit

MTABS REFERENCE VALUES						
Point Name	X	Y	Z	X	Y	Z
	[Inches]	[Inches]	[Inches]	[Metres]	[Metres]	[Metres]
MTABS_UP	0.000	-36.000	0.000	0.00000	-0.91440	0.00000
MTABS_CT	0.000	0.000	0.000	0.00000	0.00000	0.00000
MTABS_DN	0.000	36.000	0.000	0.00000	0.91440	0.00000
MTABS_TOP	0.000	0.000	0.5085	0.00000	0.00000	0.01292
MTABS_BEAM_LEFT	-0.5085	0.000	0.000	-0.01292	0.00000	0.00000

As-sets are shown relative to the Ideal Beam Sheet Position (Site coordinates for beam line: MTEST_r8.ces)

MTABS ACTUALS AS-SET LOCAL						
Point Name	X	Y	Z	X	Y	Z
	[Inches]	[Inches]	[Inches]	[Metres]	[Metres]	[Metres]
MTABS_UP						
MTABS_CT						
MTABS_DN	0.043		-0.021	0.00109	0.00000	-0.00053
MTABS_UP	0.068	-2.479	0.009	0.00173	-0.06297	0.00023
MTABS_CT	0.068	34.172	-0.006	0.00173	0.86797	-0.00015
MTABS_DN	0.069	70.823	-0.020	0.00175	1.79891	-0.00051
	ROLL(mrad)	PITCH(mrad)	YAW(mrad)			
	N/A	-0.40	0.01			

MTABS ACTUALS AS-SET FSCS (Z)			
Point Name	X	Y	Z
	[Metres]	[Metres]	[Metres]
MTABS_UP	30283.210025	32046.959490	227.167072
MTABS_CT	30282.993589	32047.864533	227.169070
MTABS_DN	30282.777153	32048.769576	227.171068
	ROLL(mrad)	PITCH(mrad)	YAW(mrad)
	N/A	-0.40	0.01

NOTES: Coordinates for the device are in the FSCS(z) coordinate system.
 (+X - axis) is East, (+Y - axis) is North, (+Z - axis) is Vertical elevation

+ve Roll is cw rotation about the +Y-axis
 +ve Pitch is the Vertical angle above the X-Y plane
 +ve Yaw is the cw rotation about the +ve Z-axis

MTBABS ABSORBER

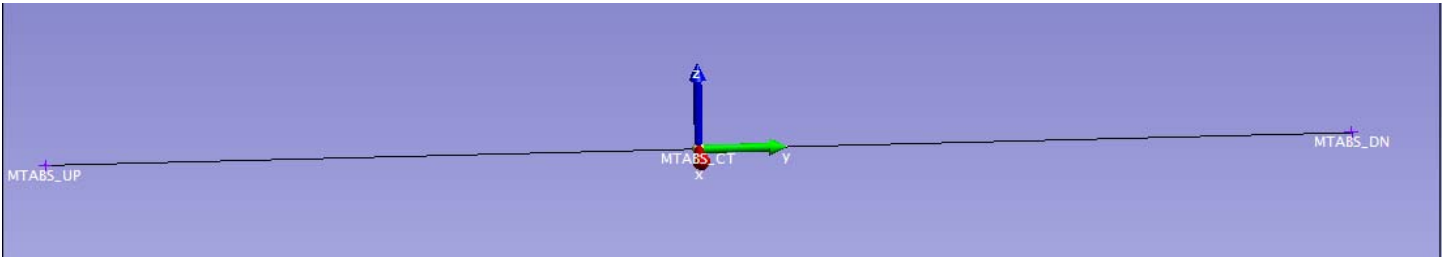

MTBABS UPSTREAM END



MTBABS DOWNSTREAM END (Looking Upstream)



MTBABS DOWNSTREAM END (Looking towards Beam Left)

33 INCH OF STICK
 1.0-INCH VERT
 1.95-INCH HORIZ.

NOTE 1: THERE IS NO ADJUSTMENTS ON THE BEAM PIPE – ASFOUND POSITION ONLY

NOTE 2: THE FLANGE IS NOT CENTERED ON THE BEAM PIPE – USED PIPE FOR ASFOUND PURPOSES

MTBABS REFERENCE VALUES						
Held The Beam Pipe						
Point Name	X	Y	Z	X	Y	Z
	[Inches]	[Inches]	[Inches]	[Metres]	[Metres]	[Metres]
MTBABS_UP_FLANGE	0.023	-37.933	-0.015	0.00058	-0.96350	-0.00038
MTBABS_CT_FLANGE	-0.085	0.000	0.152	-0.00216	0.00000	0.00386
MTBABS_DN_FLANGE	-0.193	37.933	0.319	-0.00490	0.96350	0.00810
MTBABS_UP_BEAM_PIPE	0.000	-37.933	0.000	0.00000	-0.96350	0.00000
MTBABS_CT_BEAM_PIPE	0.000	0.000	0.000	0.00000	0.00000	0.00000
MTBABS_DN_BEAM_PIPE	0.000	37.933	0.000	0.00000	0.96350	0.00000
MTBABS_TOP_BEAM_PIPE	0.000	0.000	0.500	0.00000	0.00000	0.01270
MTBABS_BEAM_LEFT_BEAM_PIPE	-0.975	0.000	0.000	-0.02476	0.00000	0.00000

As-sets are shown relative to the Ideal Beam Sheet Position (Site coordinates for beam line: MTEST_r8.ces)

MTBABS ACTUALS AS-FOUND LOCAL						
Point Name	X	Y	Z	X	Y	Z
	[Inches]	[Inches]	[Inches]	[Metres]	[Metres]	[Metres]
MTBABS_UP_BEAM_PIPE	0.024	0.921	0.034	0.00061	0.02339	0.00086
MTBABS_CT_BEAM_PIPE	-0.015	37.899	0.014	-0.00038	0.96264	0.00036
MTBABS_DN_BEAM_PIPE	-0.055	74.877	-0.006	-0.00140	1.90188	-0.00015
	ROLL(mrad)	PITCH(mrad)	YAW(mrad)			
	N/A	-0.54	-1.07			

MTBABS ACTUALS AS-FOUND FSCS (Z)			
Point Name	X	Y	Z
	[Metres]	[Metres]	[Metres]
MTBABS_UP_BEAM_PIPE	30279.657960	32061.584462	227.205952
MTBABS_CT_BEAM_PIPE	30279.431925	32062.496097	227.207843
MTBABS_DN_BEAM_PIPE	30279.205890	32063.407733	227.209734
	ROLL(mrad)	PITCH(mrad)	YAW(mrad)
	N/A	-0.54	-1.07

NOTES: Coordinates for the device are in the FSCS(z) coordinate system.

(+X - axis) is East, (+Y - axis) is North, (+Z - axis) is Vertical elevation

+ve Roll is cw rotation about the +Y-axis

+ve Pitch is the Vertical angle above the X-Y plane

+ve Yaw is the cw rotation about the +ve Z-axis

MT4Q1 FRD#11692

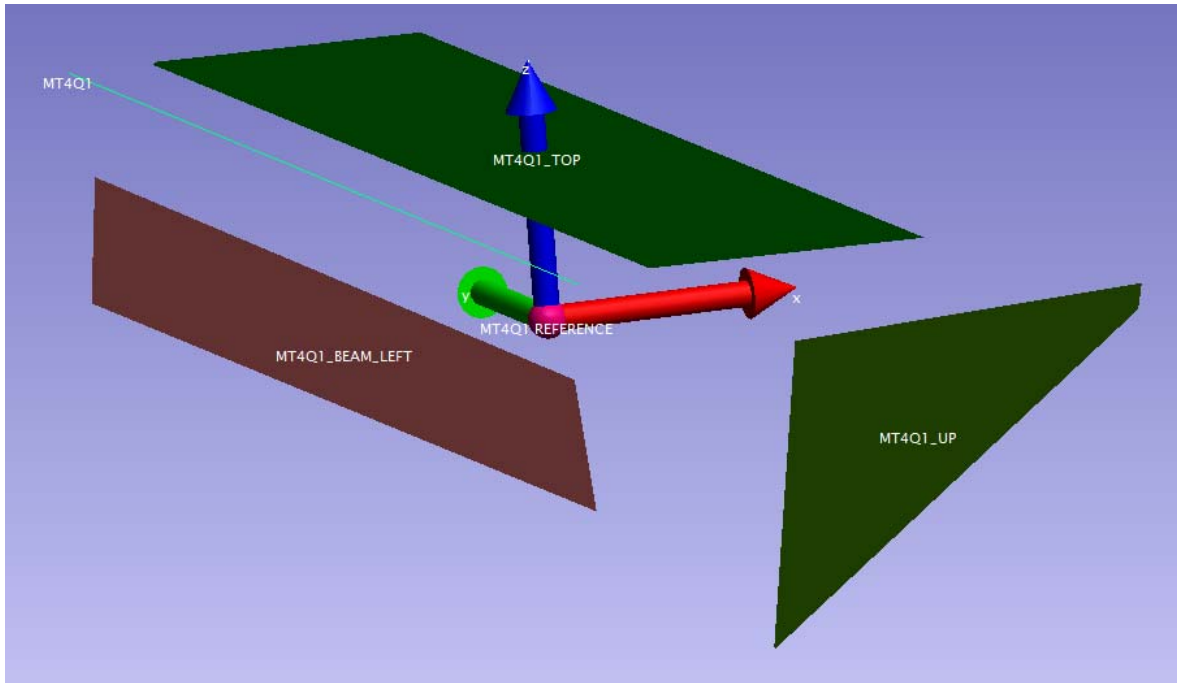

13-INCH HEIGHT
17-INCH WIDTH
120-INCH LENGTH
FRD# 11692

MT4Q1 REFERENCE VALUES						
Point Name	X	Y	Z	X	Y	Z
	[Inches]	[Inches]	[Inches]	[Metres]	[Metres]	[Metres]
MT4Q1_UP	0.000	-60.000	0.000	0.00000	-1.52400	0.00000
MT4Q1_CT	0.000	0.000	0.000	0.00000	0.00000	0.00000
MT4Q1_DN	0.000	60.000	0.000	0.00000	1.52400	0.00000
MT4Q1_TOP	0.000	0.000	6.500	0.00000	0.00000	0.16510
MT4Q1_BEAM_LEFT	-8.500	0.000	0.000	-0.21590	0.00000	0.00000

As-sets are shown relative to the Ideal Beam Sheet Position (Site coordinates for beam line: MTEST_r8.ces)

MT4Q1 ACTUALS AS-SET LOCAL						
Point Name	X	Y	Z	X	Y	Z
	[Inches]	[Inches]	[Inches]	[Metres]	[Metres]	[Metres]
MT4Q1_UP	0.001	-0.476	0.001	0.00003	-0.01209	0.00003
MT4Q1_CT	0.004	59.524	-0.003	0.00010	1.51191	-0.00008
MT4Q1_DN	0.007	119.524	-0.006	0.00018	3.03592	-0.00015
	ROLL(mrad)	PITCH(mrad)	YAW(mrad)			
	-0.09	-0.06	0.05			

MT4Q1 ACTUALS AS-SET FSCS (Z)			
Point Name	X	Y	Z
	[Metres]	[Metres]	[Metres]
MT4Q1_UP	30282.701621	32049.085809	227.172417
MT4Q1_CT	30282.348370	32050.568299	227.176208
MT4Q1_DN	30281.995120	32052.050789	227.179999
	ROLL(mrad)	PITCH(mrad)	YAW(mrad)
	-0.09	-0.06	0.05

NOTES: Coordinates for the device are in the FSCS(z) coordinate system.

(+X - axis) is East, (+Y - axis) is North, (+Z - axis) is Vertical elevation

+ve Roll is cw rotation about the +Y-axis

+ve Pitch is the Vertical angle above the X-Y plane

+ve Yaw is the cw rotation about the +ve Z-axis

MT4W1 FRD#20706

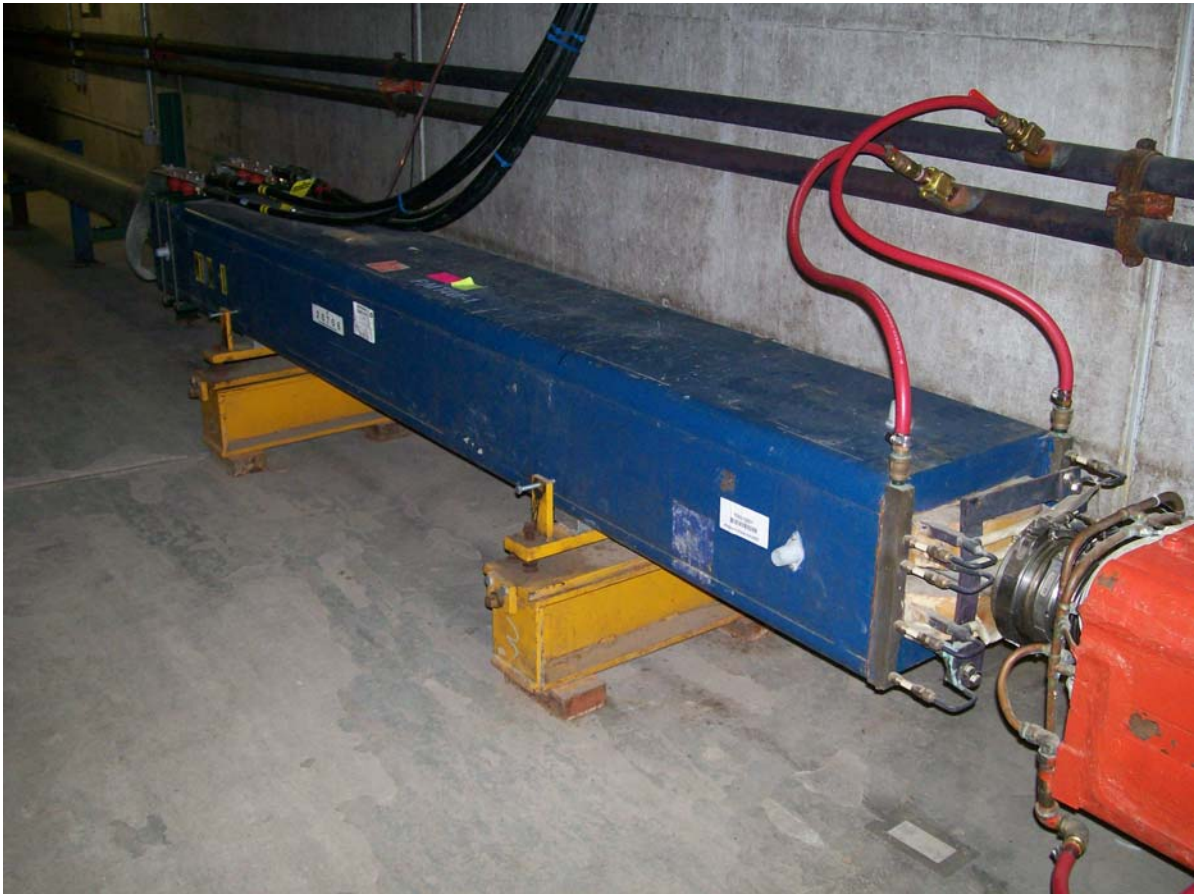
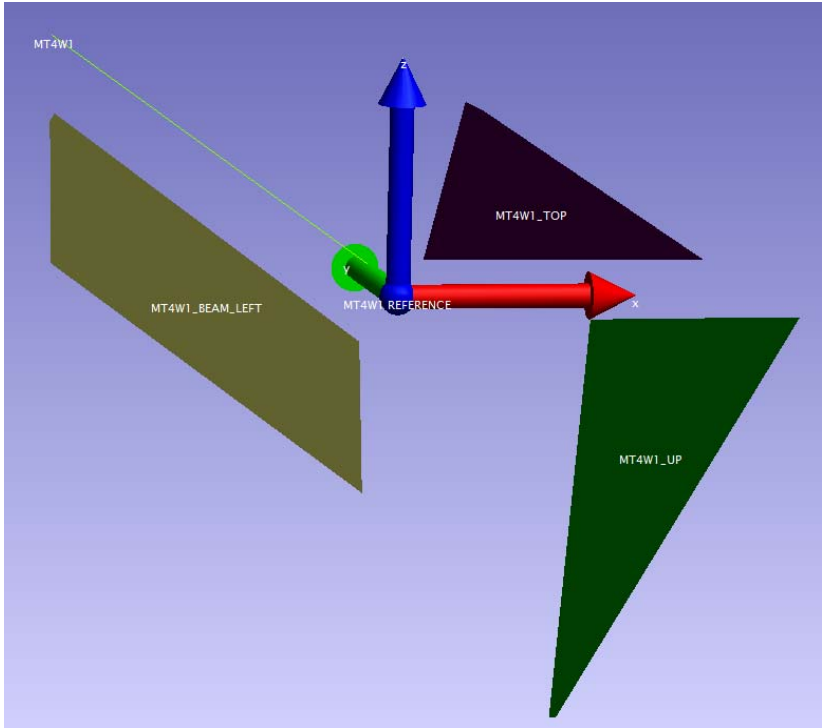

12.5-INCH HEIGHT
16-INCH WIDTH
120-INCH LENGTH

MT4W1 REFERENCE VALUES						
Point Name	X	Y	Z	X	Y	Z
	[Inches]	[Inches]	[Inches]	[Metres]	[Metres]	[Metres]
MT4W1_UP	0.000	-60.000	0.000	0.00000	-1.52400	0.00000
MT4W1_CT	0.000	0.000	0.000	0.00000	0.00000	0.00000
MT4W1_DN	0.000	60.000	0.000	0.00000	1.52400	0.00000
MT4W1_TOP	0.000	0.000	6.250	0.00000	0.00000	0.15875
MT4W1_BEAM_LEFT	-8.000	0.000	0.000	-0.20320	0.00000	0.00000

As-sets are shown relative to the Ideal Beam Sheet Position (Site coordinates for beam line: MTEST_r8.ces)

MT4W1 ACTUALS AS-SET LOCAL						
Point Name	X	Y	Z	X	Y	Z
	[Inches]	[Inches]	[Inches]	[Metres]	[Metres]	[Metres]
MT4W1_UP	0.029	-0.289	-0.007	0.00074	-0.00734	-0.00018
MT4W1_CT	0.002	59.711	-0.005	0.00005	1.51666	-0.00013
MT4W1_DN	-0.025	119.711	-0.002	-0.00064	3.04067	-0.00005
	ROLL(mrad)	PITCH(mrad)	YAW(mrad)			
	0.18	0.04	-0.45			

MT4W1 ACTUALS AS-SET FSCS(Z)			
Point Name	X	Y	Z
	[Metres]	[Metres]	[Metres]
MT4W1_UP	30281.917679	32052.378250	227.180823
MT4W1_CT	30281.557757	32053.859136	227.184761
MT4W1_DN	30281.197836	32055.340020	227.188698
	ROLL(mrad)	PITCH(mrad)	YAW(mrad)
	0.18	0.04	-0.45

NOTES: Coordinates for the device are in the FSCS(z) coordinate system.

(+X - axis) is East, (+Y - axis) is North, (+Z - axis) is Vertical elevation

+ve Roll is cw rotation about the +Y-axis

+ve Pitch is the Vertical angle above the X-Y plane

+ve Yaw is the cw rotation about the +ve Z-axis

MT4Q2 FRD#10313

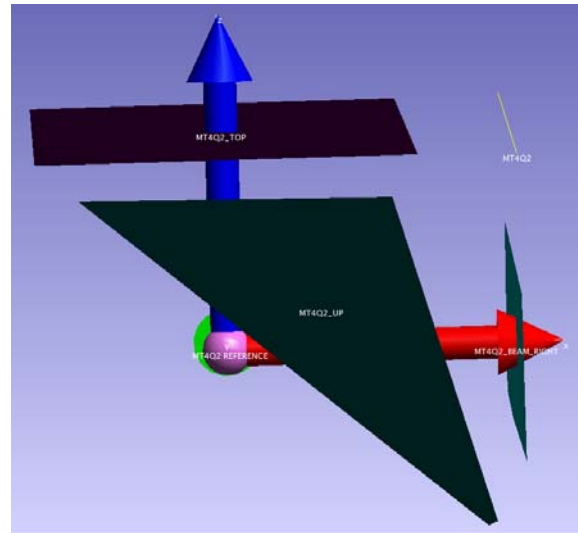

13-INCH HEIGHT
17-INCH WIDTH
120-INCH LENGTH
FRD# 10313

MT4Q2 REFERENCE VALUES						
Point Name	X	Y	Z	X	Y	Z
	[Inches]	[Inches]	[Inches]	[Metres]	[Metres]	[Metres]
MT4Q2_UP	0.000	-60.000	0.000	0.00000	-1.52400	0.00000
MT4Q2_CT	0.000	0.000	0.000	0.00000	0.00000	0.00000
MT4Q2_DN	0.000	60.000	0.000	0.00000	1.52400	0.00000
MT4Q2_TOP	0.000	0.000	6.500	0.00000	0.00000	0.16510
MT4Q2_BEAM_RIGHT	8.500	0.000	0.000	0.21590	0.00000	0.00000

As-sets are shown relative to the Ideal Beam Sheet Position (Site coordinates for beam line: MTEST_r8.ces)

MT4Q2 ACTUALS AS-SET LOCAL						
Point Name	X	Y	Z	X	Y	Z
	[Inches]	[Inches]	[Inches]	[Metres]	[Metres]	[Metres]
MT4Q2_UP	-0.006	-0.088	-0.000	-0.00015	-0.00224	0.00000
MT4Q2_CT	-0.006	59.912	-0.004	-0.00015	1.52177	-0.00010
MT4Q2_DN	-0.006	119.912	-0.007	-0.00015	3.04577	-0.00018
	ROLL(mrad)	PITCH(mrad)	YAW(mrad)			
	0.18	-0.06	-0.01			

MT4Q2 ACTUALS AS-SET FSCS (Z)			
Point Name	X	Y	Z
	[Metres]	[Metres]	[Metres]
MT4Q2_UP	30278.682870	32065.532033	227.215434
MT4Q2_CT	30278.317681	32067.011633	227.219216
MT4Q2_DN	30277.952493	32068.491227	227.222998
	ROLL(mrad)	PITCH(mrad)	YAW(mrad)
	0.18	-0.06	-0.01

NOTES: Coordinates for the device are in the FSCS(z) coordinate system.

(+X - axis) is East, (+Y - axis) is North, (+Z - axis) is Vertical elevation

+ve Roll is cw rotation about the +Y-axis

+ve Pitch is the Vertical angle above the X-Y plane

+ve Yaw is the cw rotation about the +ve Z-axis

MT4W2 FRD#50394

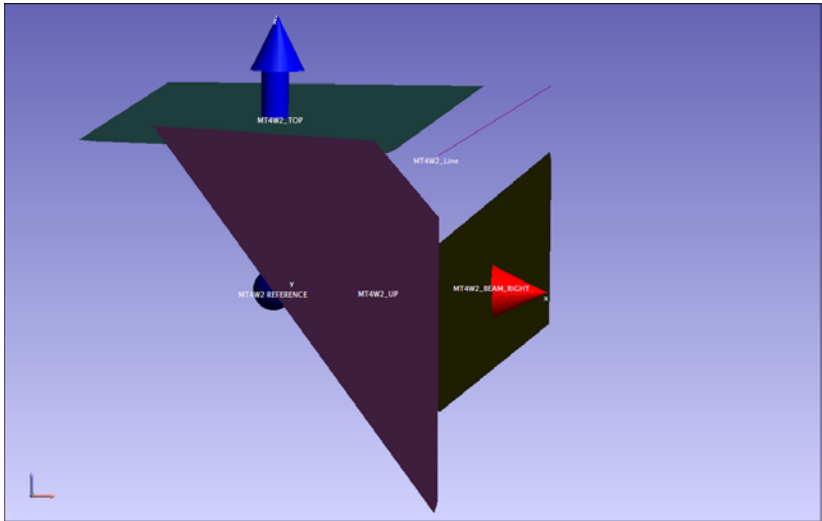

12.5-INCH HEIGHT
16 INCH WIDE
FRD50394

MT4W2 REFERENCE VALUES						
Point Name	X	Y	Z	X	Y	Z
	[Inches]	[Inches]	[Inches]	[Metres]	[Metres]	[Metres]
MT4W2_UP	0.000	-60.000	0.000	0.00000	-1.52399	0.00000
MT4W2_CT	0.000	0.000	0.000	0.00000	0.00000	0.00000
MT4W2_DN	0.000	60.000	0.000	0.00000	1.52399	0.00000
MT4W2_TOP	0.000	0.000	6.250	0.00000	0.00000	0.15875
MT4W2_BEAM_RIGHT	8.000	0.000	0.000	0.20320	0.00000	0.00000

As-sets are shown relative to the Ideal Beam Sheet Position (Site coordinates for beam line: MTEST_r8.ces)

MT4W2 ACTUALS AS-SET LOCAL						
Point Name	X	Y	Z	X	Y	Z
	[Inches]	[Inches]	[Inches]	[Metres]	[Metres]	[Metres]
MT4W2_UP	-0.008	-0.231	-0.008	-0.00020	-0.00587	-0.00020
MT4W2_CT	-0.007	59.769	-0.006	-0.00018	1.51814	-0.00015
MT4W2_DN	-0.006	119.769	-0.003	-0.00015	3.04214	-0.00008
	ROLL(mrad)	PITCH(mrad)	YAW(mrad)			
	-0.02	0.04	0.02			

MT4W2 ACTUALS AS-SET FSCS(Z)			
Point Name	X	Y	Z
	[Metres]	[Metres]	[Metres]
MT4W2_UP	30277.799652	32069.110360	227.224601
MT4W2_CT	30277.428584	32070.588490	227.228534
MT4W2_DN	30277.057516	32072.066620	227.232467
	ROLL(mrad)	PITCH(mrad)	YAW(mrad)
	-0.02	0.04	0.02

NOTES: Coordinates for the device are in the FSCS(z) coordinate system.

(+X - axis) is East, (+Y - axis) is North, (+Z - axis) is Vertical elevation

+ve Roll is cw rotation about the +Y-axis

+ve Pitch is the Vertical angle above the X-Y plane

+ve Yaw is the cw rotation about the +ve Z-axis

MT4Q3 FRD#10319

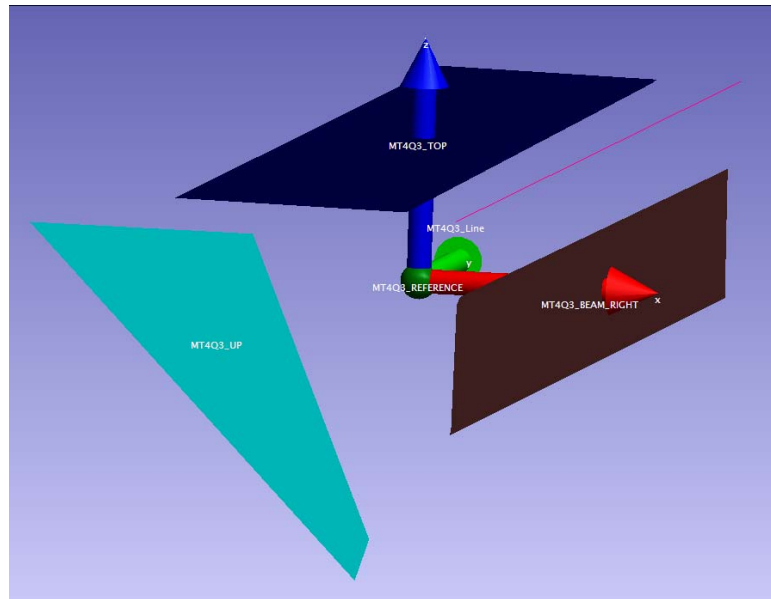

13-INCH HEIGHT
17 INCH WIDE
FRD10319

MT4Q3 REFERENCE VALUES						
Point Name	X	Y	Z	X	Y	Z
	[Inches]	[Inches]	[Inches]	[Metres]	[Metres]	[Metres]
MT4Q3_UP	0.000	-60.000	0.000	0.00000	-1.52400	0.00000
MT4Q3_CT	0.000	0.000	0.000	0.00000	0.00000	0.00000
MT4Q3_DN	0.000	60.000	0.000	0.00000	1.52400	0.00000
MT4Q3_TOP	0.000	0.000	6.500	0.00000	0.00000	0.16510
MT4Q3_BEAM_RIGHT	8.500	0.000	0.000	0.21590	0.00000	0.00000

As-sets are shown relative to the Ideal Beam Sheet Position (Site coordinates for beam line: MTEST_r8.ces)

MT4Q3 ACTUALS AS-SET LOCAL						
Point Name	X	Y	Z	X	Y	Z
	[Inches]	[Inches]	[Inches]	[Metres]	[Metres]	[Metres]
MT4Q3_UP	-0.015	-0.046	-0.008	-0.00038	-0.00117	-0.00020
MT4Q3_CT	-0.012	59.954	-0.004	-0.00030	1.52283	-0.00010
MT4Q3_DN	-0.010	119.954	-0.000	-0.00025	3.04684	0.00000
	ROLL(mrad)	PITCH(mrad)	YAW(mrad)			
	0.39	0.07	0.04			

MT4Q3 ACTUALS AS-SET FSCS(Z)			
Point Name	X	Y	Z
	[Metres]	[Metres]	[Metres]
MT4Q3_UP	30276.893830	32072.706926	227.234034
MT4Q3_CT	30276.516888	32074.183569	227.238003
MT4Q3_DN	30276.139945	32075.660212	227.241972
	ROLL(mrad)	PITCH(mrad)	YAW(mrad)
	0.39	0.07	0.04

NOTES: Coordinates for the device are in the FSCS(z) coordinate system.

(+X - axis) is East, (+Y - axis) is North, (+Z - axis) is Vertical elevation

+ve Roll is cw rotation about the +Y-axis

+ve Pitch is the Vertical angle above the X-Y plane

+ve Yaw is the cw rotation about the +ve Z-axis

MT4CV1 FRD#50052

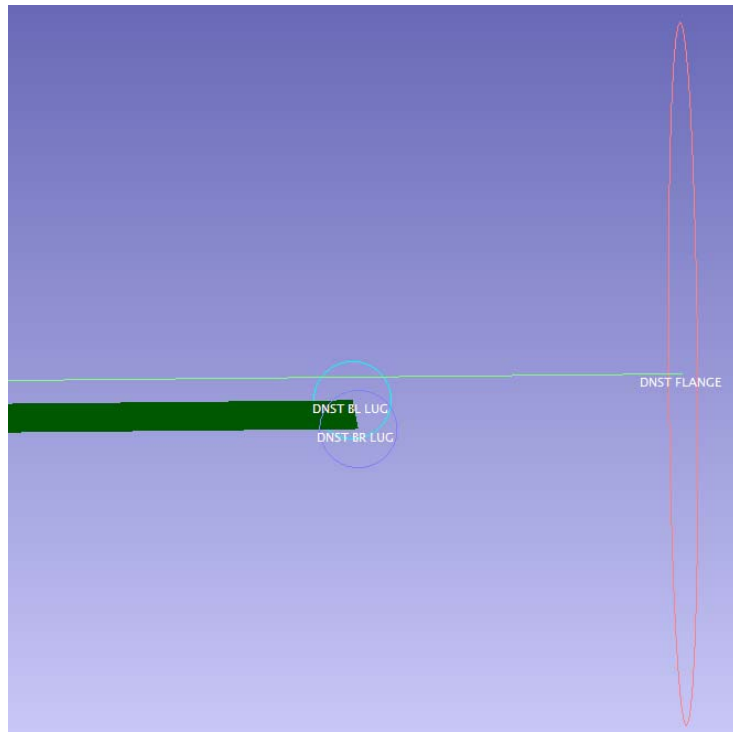
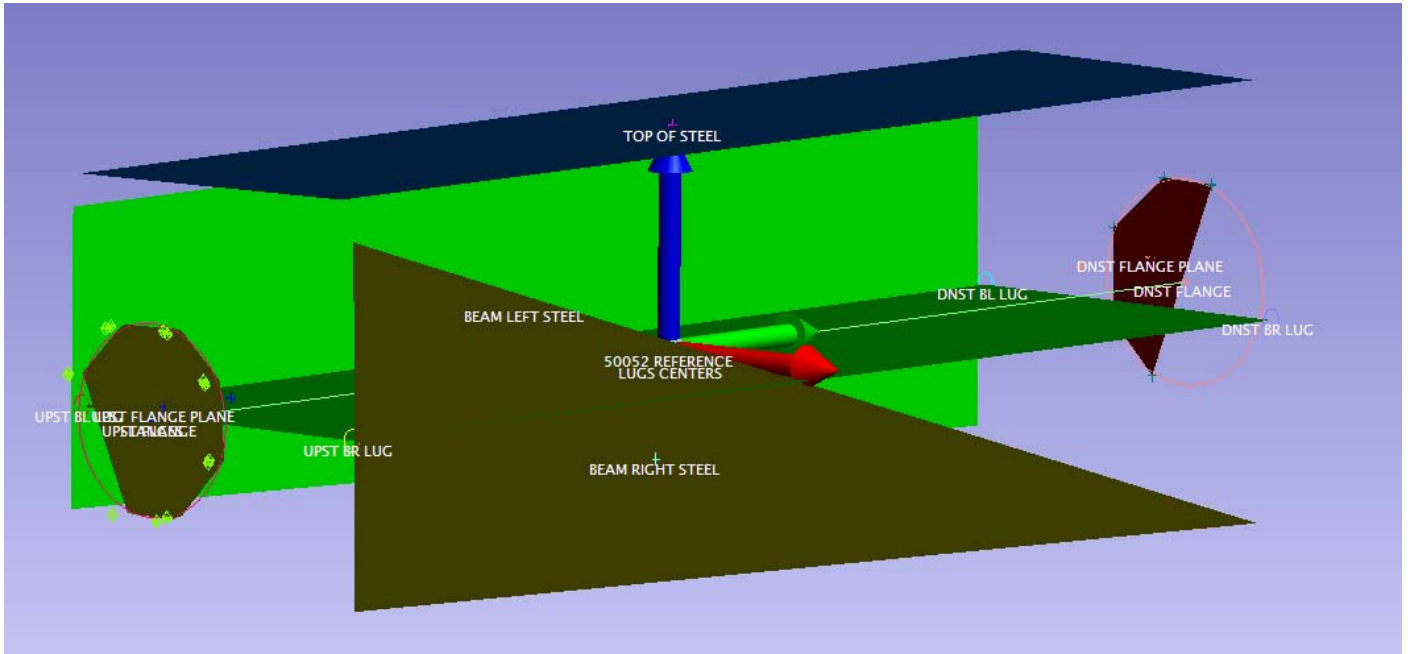



MT4CV1 UPSTREAM – BEAM RIGHT VIEW



MT4CV1 UPSTREAM – BEAM LEFT VIEW

FRD50052
68 INCH LONG
REFERENCE BY LT 09-NOV-06: 50052_ref_JCK [v2].xit
As-set 15-Feb-07: mt4vt_JCK [V1].xit

MT4CV1 REFERENCE VALUES						
Point Name	X	Y	Z	X	Y	Z
	[Inches]	[Inches]	[Inches]	[Metres]	[Metres]	[Metres]
50052_DN_TOP_BEAM_RIGHT_STEEL	7.715	29.984	10.014	0.19596	0.76160	0.25436
50052_DN_TOP_BEAM_LEFT_STEEL	-6.839	30.996	9.976	-0.17371	0.78730	0.25339
50052_UP_TOP_BEAM_LEFT_STEEL	-7.200	-31.094	10.033	-0.18288	-0.78979	0.25484
50052_UP_TOP_BEAM_RIGHT_STEEL	7.303	-30.238	10.061	0.18550	-0.76805	0.25555
50052_UP_BEAM_LEFT_TOP_STEEL	-8.246	-30.373	8.397	-0.20945	-0.77148	0.21328
50052_UP_BEAM_LEFT_BOTTOM_STEEL	-8.232	-30.409	-5.004	-0.20909	-0.77239	-0.12710
50052_DN_BEAM_LEFT_BOTTOM_STEEL	-8.253	30.055	-6.721	-0.20963	0.76340	-0.17071
50052_DN_BEAM_LEFT_TOP_STEEL	-8.257	29.880	8.321	-0.20973	0.75895	0.21135
50052_UP_BEAM_RIGHT_TOP_STEEL	8.286	-30.498	8.280	0.21046	-0.77465	0.21031
50052_UP_BEAM_RIGHT_BOTTOM_STEEL	8.339	-30.287	-8.105	0.21181	-0.76929	-0.20587
50052_DN_BEAM_RIGHT_BOTTOM_STEEL	8.333	29.782	-9.557	0.21166	0.75646	-0.24275
50052_UP_STEEL	0.000	-34.000	0.000	0.00000	-0.86360	0.00000
50052_CT_STEEL	0.000	0.000	0.000	0.00000	0.00000	0.00000
50052_DN_STEEL	0.000	34.000	0.000	0.00000	0.86360	0.00000
50052_UP_FLANGE	0.000	-34.398	-0.000	0.00000	-0.87371	0.00000
50052_CT_FLANGE	0.000	0.000	-0.012	0.00000	0.00000	-0.00030
50052_DN_FLANGE	0.000	34.398	-0.023	0.00000	0.87371	-0.00058
50052_UP_BEAM_RIGHT_LUG	8.295	-30.552	-0.499	0.21069	-0.77602	-0.01267
50052_DN_BEAM_RIGHT_LUG	9.090	29.785	-0.501	0.23089	0.75654	-0.01273
50052_DN_BEAM_LEFT_LUG	-8.254	30.443	-0.499	-0.20965	0.77325	-0.01267
50052_UP_BEAM_LEFT_LUG	-8.233	-29.764	-0.501	-0.20912	-0.75601	-0.01273

As-sets are shown relative to the Ideal Beam Sheet Position (Site coordinates for beam line: MTEST_r8.ces)

MT4CV1 ACTUALS AS-SET LOCAL						
Point Name	X	Y	Z	X	Y	Z
	[Inches]	[Inches]	[Inches]	[Metres]	[Metres]	[Metres]
50052_UP_STEEL	0.005	-0.939	-0.003	0.00013	-0.02385	-0.00008
50052_CT_STEEL	0.006	33.061	0.004	0.00015	0.83975	0.00010
50052_DN_STEEL	0.008	67.061	0.012	0.00020	1.70335	0.00030
	ROLL(mrad)	PITCH(mrad)	YAW(mrad)			
	-0.90	0.21	0.03			

MT4CV1 ACTUALS AS-SET FSCS(Z)			
Point Name	X	Y	Z
	[Metres]	[Metres]	[Metres]
50052_UP_STEEL	30276.024978	32076.112086	227.243099
50052_CT_STEEL	30275.811369	32076.948848	227.245475
50052_DN_STEEL	30275.597761	32077.785610	227.247851
	ROLL(mrad)	PITCH(mrad)	YAW(mrad)
	-0.90	0.21	0.03

NOTES: Coordinates for the device are in the FSCS(z) coordinate system.

(+X - axis) is East, (+Y - axis) is North, (+Z - axis) is Vertical elevation

+ve Roll is cw rotation about the +Y-axis

+ve Pitch is the Vertical angle above the X-Y plane

+ve Yaw is the cw rotation about the +ve Z-axis

MT4VT FRD#10311

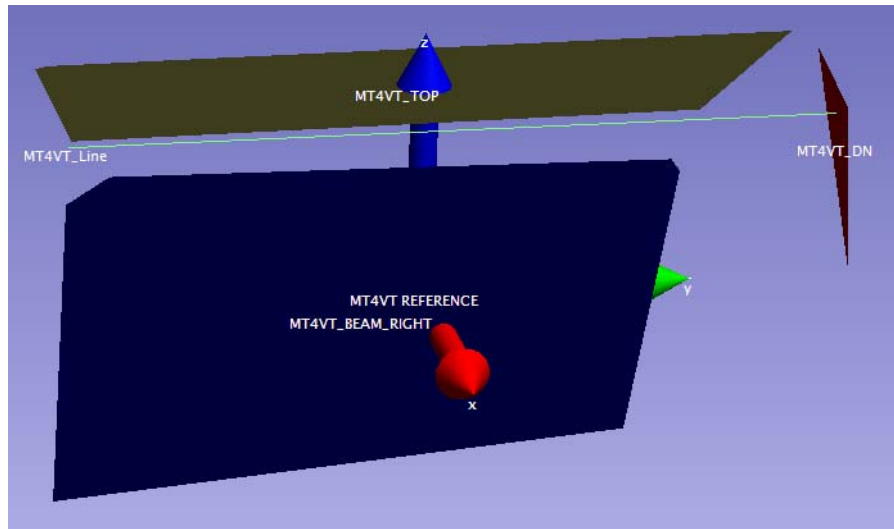

FRD10311
16.0 INCH HIGH
8.75 INCH WIDE
30 INCH LONG

MT4VT REFERENCE VALUES						
Point Name	X	Y	Z	X	Y	Z
	[Inches]	[Inches]	[Inches]	[Metres]	[Metres]	[Metres]
MT4VT_UP	0.000	-15.000	0.000	0.00000	-0.38100	0.00000
MT4VT_CT	0.000	0.000	0.000	0.00000	0.00000	0.00000
MT4VT_DN	-0.000	15.000	0.000	0.00000	0.38100	0.00000
MT4VT_TOP	0.000	0.000	8.000	0.00000	0.00000	0.20320
MT4VT_BEAM_RIGHT	4.375	0.000	0.000	0.11113	0.00000	0.00000

As-sets are shown relative to the Ideal Beam Sheet Position (Site coordinates for beam line: MTEST_r8.ces)

MT4VT ACTUALS AS-SET LOCAL						
Point Name	X	Y	Z	X	Y	Z
	[Inches]	[Inches]	[Inches]	[Metres]	[Metres]	[Metres]
MT4VT_UP	0.047	-0.098	0.002	0.00119	-0.00249	0.00005
MT4VT_CT	0.050	14.902	-0.008	0.00127	0.37851	-0.00020
MT4VT_DN	0.053	29.902	-0.018	0.00135	0.75951	-0.00046
	ROLL(mrad)	PITCH(mrad)	YAW(mrad)			
	6.59	0.69	0.22			

MT4VT ACTUALS AS-SET FSCS(Z)			
Point Name	X	Y	Z
	[Metres]	[Metres]	[Metres]
MT4VT_UP	30275.498851	32078.177051	227.248646
MT4VT_CT	30275.404681	32078.546229	227.249354
MT4VT_DN	30275.310508	32078.915418	227.250062
	ROLL(mrad)	PITCH(mrad)	YAW(mrad)
	6.59	0.69	0.22

NOTES: Coordinates for the device are in the FSCS(z) coordinate system.

(+X - axis) is East, (+Y - axis) is North, (+Z - axis) is Vertical elevation

+ve Roll is cw rotation about the +Y-axis

+ve Pitch is the Vertical angle above the X-Y plane

+ve Yaw is the cw rotation about the +ve Z-axis

MT4FP [6301245] AS-SET

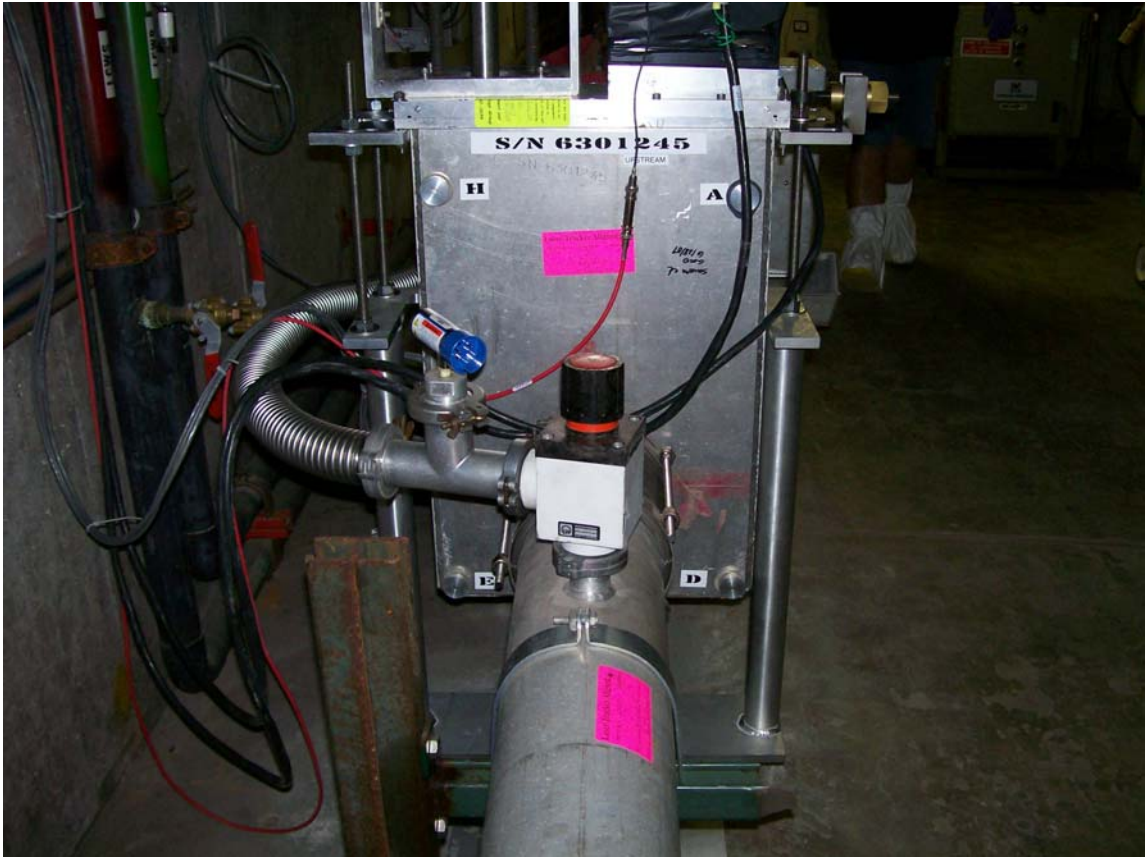
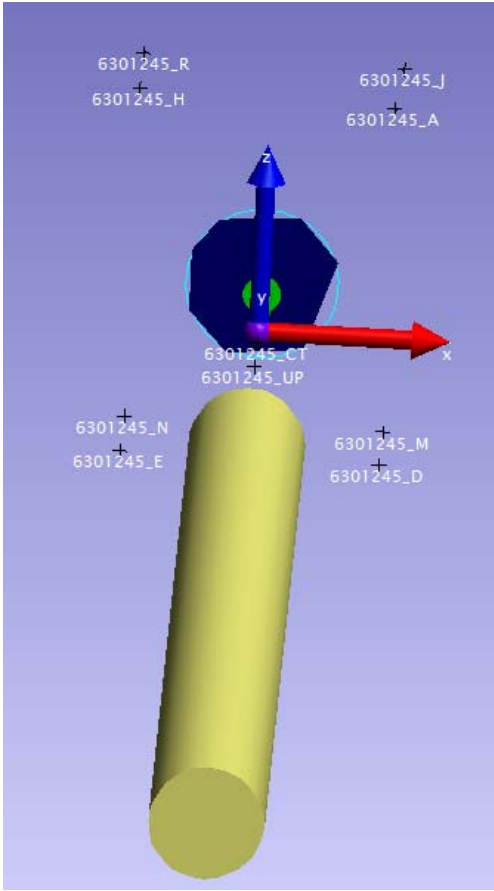

UPSTREAM VIEW



DOWNSTREAM VIEW



BEAM RIGHT VIEW

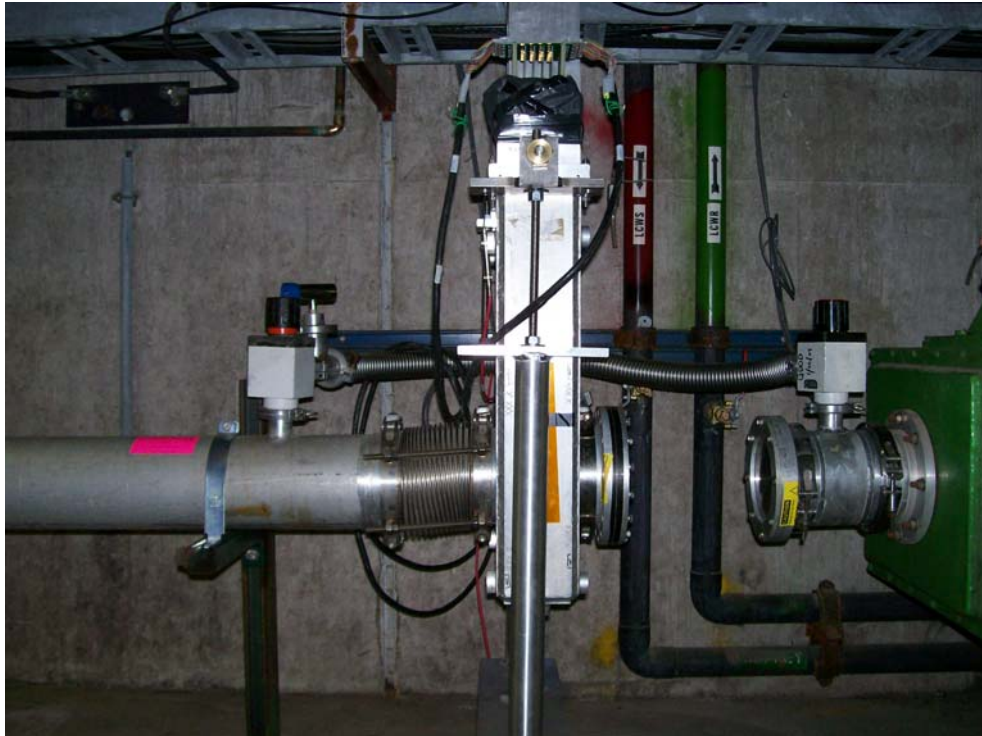
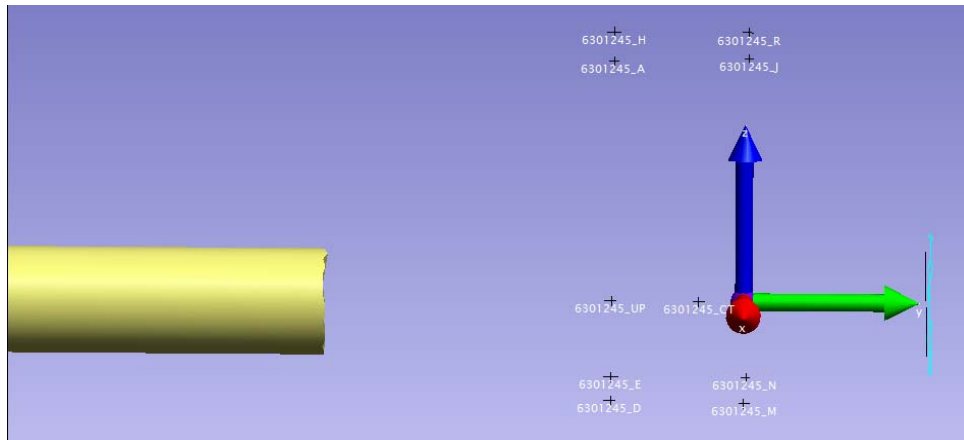

BEAM RIGHT VIEW

NOTE: Crew was asked NOT to move beam pipe. Techs were concerned about possibly losing vacuum.

Reference File located in: G:\projects\7013\fpm\6301245

MT4FP1 [6301245] REFERENCE VALUES						
Point Name	X [Inches]	Y [Inches]	Z [Inches]	X [Metres]	Y [Metres]	Z [Metres]
6301245_A	6.576	-4.981	14.203	0.16703	-0.12652	0.36075
6301245_D	6.733	-5.007	-4.952	0.17102	-0.12718	-0.12579
6301245_E	-6.705	-4.984	-4.972	-0.17032	-0.12659	-0.12630
6301245_H	-6.681	-5.008	14.508	-0.16969	-0.12719	0.36850
6301245_J	6.795	2.679	14.465	0.17260	0.06805	0.36741
6301245_M	6.744	2.642	-5.013	0.17130	0.06709	-0.12734
6301245_N	-6.693	2.661	-4.955	-0.17001	0.06758	-0.12586
6301245_R	-6.668	2.636	14.548	-0.16938	0.06694	0.36951
6301245_UP	0.000	-4.996	0.000	0.00000	-0.12689	0.00000
6301245_CT	0.000	0.000	0.000	0.00000	0.00000	0.00000
6301245_DN	0.000	2.648	0.000	0.00000	0.06726	0.00000

As-sets are shown relative to the Ideal Beam Sheet Position (Site coordinates for beam line: MTEST_r8.ces)

MT4FP1 [6301245] ACTUALS AS-SET LOCAL						
Point Name	X	Y	Z	X	Y	Z
	[Inches]	[Inches]	[Inches]	[Metres]	[Metres]	[Metres]
6301245_UP	0.022	-2.515	0.010	0.00056	-0.06389	0.00026
6301245_CT	0.017	-2.515	-0.004	0.00042	-0.06389	-0.00010
6301245_DN	0.014	-2.515	-0.012	0.00035	-0.06389	-0.00029
	ROLL(mrad)	PITCH(mrad)	YAW(mrad)			
	1.52	-2.88	-1.05			

MT5FP1 [6301245] ACTUALS AS-SET FSCS(Z)			
Point Name	X	Y	Z
	[Metres]	[Metres]	[Metres]
6301245_UP	30274.396632	32082.491566	227.260170
6301245_CT	30274.365114	32082.614480	227.260127
6301245_DN	30274.348407	32082.679632	227.260104
	ROLL(mrad)	PITCH(mrad)	YAW(mrad)
	1.52	-2.88	-1.05

MT4FP BEAM PIPE UPSTREAM ACTUALS AS-FOUND LOCAL						
Point Name	X	Y	Z	X	Y	Z
	[Inches]	[Inches]	[Inches]	[Metres]	[Metres]	[Metres]
6" _BEAM_PIPE_UP	0.090	-105.937	-0.269	0.00227	-2.69079	-0.00684
6" _BEAM_PIPE_CT	0.067	-64.856	-0.219	0.00170	-1.64735	-0.00557
6" _BEAM_PIPE_DN	0.044	-23.776	-0.170	0.00113	-0.60392	-0.00431

NOTES: Coordinates for the device are in the FSCS(z) coordinate system.

(+X - axis) is East, (+Y - axis) is North, (+Z - axis) is Vertical elevation

+ve Roll is cw rotation about the +Y-axis

+ve Pitch is the Vertical angle above the X-Y plane

+ve Yaw is the cw rotation about the +ve Z-axis

MT4CH1 FRD#50033

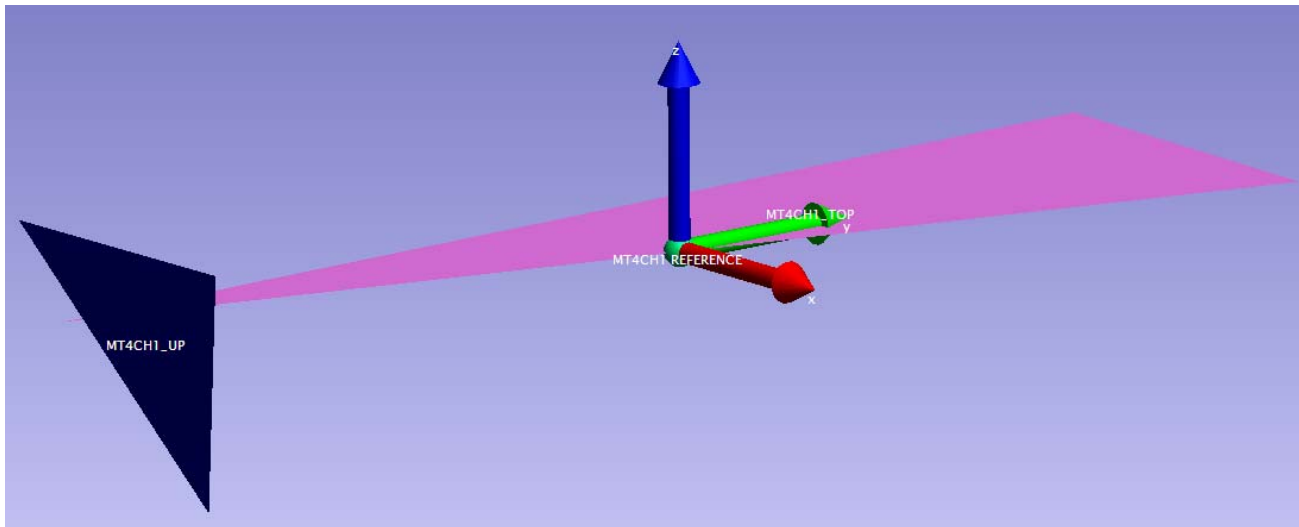

MT4CH1 UPSTREAM – BEAM RIGHT VIEW

09Nov06_lt: 50033 _Reference_jck.xit
FRD # 50033
67.5 INCH LONG
15Feb07 As-set: MT4CH1_JCK.xit

MT4CH1 REFERENCE VALUES						
Point Name	X	Y	Z	X	Y	Z
	[Inches]	[Inches]	[Inches]	[Metres]	[Metres]	[Metres]
MT4CH1_TOP_UP_BEAM_LEFT	-7.834	-30.077	8.226	-0.19898	-0.76396	0.20894
MT4CH1_TOP_DN_BEAM_LEFT	-8.967	30.391	8.334	-0.22776	0.77193	0.21168
MT4CH1_TOP_DN_BEAM_RIGHT	8.152	29.987	8.305	0.20706	0.76167	0.21095
MT4CH1_DN_BEAM_RIGHT_TOP	10.133	30.574	7.334	0.25738	0.77658	0.18628
MT4CH1_DN_BEAM_RIGHT_BOTTOM	10.113	30.919	-7.410	0.25687	0.78534	-0.18821
MT4CH1_UP_BEAM_RIGHT_BOTTOM	9.970	-30.029	-7.232	0.25324	-0.76274	-0.18369
MT4CH1_UP_BEAM_RIGHT_TOP	9.920	-30.622	7.082	0.25197	-0.77780	0.17988
MT4CH1_UP	-0.000	-33.750	0.000	0.00000	-0.85725	0.00000
MT4CH1_CT	0.000	0.000	0.000	0.00000	0.00000	0.00000
MT4CH1_DN	-0.000	33.750	0.000	0.00000	0.85725	0.00000

As-sets are shown relative to the Ideal Beam Sheet Position (Site coordinates for beam line: MTEST_r8.ces)

MT4CH1 ACTUALS AS-SET LOCAL						
Point Name	X	Y	Z	X	Y	Z
	[Inches]	[Inches]	[Inches]	[Metres]	[Metres]	[Metres]
MT4CH1_UP	-0.009	-0.667	0.000	-0.00023	-0.01694	0.00000
MT4CH1_CT	-0.003	33.083	0.001	-0.00008	0.84031	0.00003
MT4CH1_DN	0.003	66.833	0.001	0.00008	1.69756	0.00003
	ROLL(mrad)	PITCH(mrad)	YAW(mrad)			
	0.39	0.02	0.19			

MT4CV1 ACTUALS AS-SET FSCS(Z)			
Point Name	X	Y	Z
	[Metres]	[Metres]	[Metres]
MT4CH1_UP	30274.220130	32083.179704	227.261707
MT4CH1_CT	30274.008219	32084.010346	227.263902
MT4CH1_DN	30273.796309	32084.840988	227.266096
	ROLL(mrad)	PITCH(mrad)	YAW(mrad)
	0.39	0.02	0.19

NOTES: Coordinates for the device are in the FSCS(z) coordinate system.

(+X - axis) is East, (+Y - axis) is North, (+Z - axis) is Vertical elevation

+ve Roll is cw rotation about the +Y-axis

+ve Pitch is the Vertical angle above the X-Y plane

+ve Yaw is the cw rotation about the +ve Z-axis

BEAM PIPE BETWEEN MT4CH1 AND MT4HT

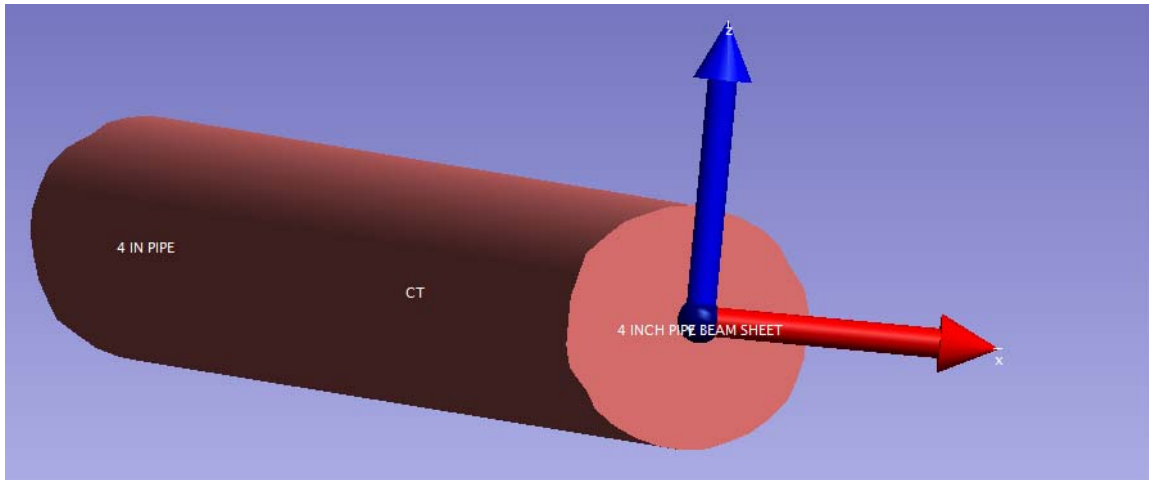

As-sets are shown relative to the Ideal Beam Sheet Position (Site coordinates for beam line: MTEST_r8.ces)

ACTUALS AS-SET LOCAL						
Point Name	X	Y	Z	X	Y	Z
	[Inches]	[Inches]	[Inches]	[Metres]	[Metres]	[Metres]
UP	-0.269	-0.000	-0.135	-0.00683	0.00000	-0.00343
CT	-0.329	120.665	-0.245	-0.00836	3.06490	-0.00622
DN	-0.389	241.330	-0.355	-0.00988	6.12979	-0.00902
	ROLL(mrad)	PITCH(mrad)	YAW(mrad)			
		-0.91	-0.49			

ACTUALS AS-SET FSCS(Z)			
Point Name	X	Y	Z
	[Metres]	[Metres]	[Metres]
UP	30273.626162	32085.479437	227.264304
CT	30272.866523	32088.448696	227.269281
DN	30272.106883	32091.417955	227.274258
	ROLL(mrad)	PITCH(mrad)	YAW(mrad)
		-0.91	-0.49

NOTES: Coordinates for the device are in the FSCS(z) coordinate system.

(+X - axis) is East, (+Y - axis) is North, (+Z - axis) is Vertical elevation

+ve Roll is cw rotation about the +Y-axis

+ve Pitch is the Vertical angle above the X-Y plane

+ve Yaw is the cw rotation about the +ve Z-axis

MT4HT FRD#11657

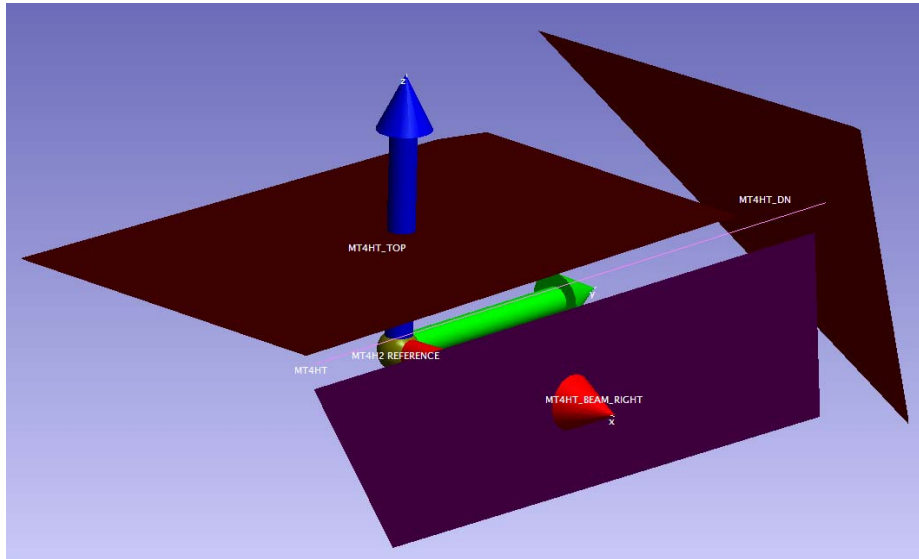

FRD11657
8.75- INCH HIGH
16- INCH WIDE
30-INCH LENGTH

MT4HT REFERENCE VALUES						
Point Name	X	Y	Z	X	Y	Z
	[Inches]	[Inches]	[Inches]	[Metres]	[Metres]	[Metres]
MT4HT_UP	0.000	-15.000	0.000	0.00000	-0.38100	0.00000
MT4HT_CT	0.000	0.000	0.000	0.00000	0.00000	0.00000
MT4HT_DN	0.000	15.000	0.000	0.00000	0.38100	0.00000
MT4HT_TOP	0.000	0.000	4.375	0.00000	0.00000	0.11113
MT4HT_BEAM_RIGHT	8.000	0.000	0.000	0.20320	0.00000	0.00000

As-sets are shown relative to the Ideal Beam Sheet Position (Site coordinates for beam line: MTEST_r8.ces)

MT4HT ACTUALS AS-SET LOCAL						
Point Name	X	Y	Z	X	Y	Z
	[Inches]	[Inches]	[Inches]	[Metres]	[Metres]	[Metres]
MT4HT_UP	-0.040	-0.260	-0.044	-0.00102	-0.00660	-0.00112
MT4HT_CT	-0.025	14.740	-0.021	-0.00064	0.37440	-0.00053
MT4HT_DN	-0.010	29.739	0.002	-0.00025	0.75537	0.00005
	ROLL(mrad)	PITCH(mrad)	YAW(mrad)			
	0.58	1.55	1.01			

MT4HT ACTUALS AS-SET FSCS(Z)			
Point Name	X	Y	Z
	[Metres]	[Metres]	[Metres]
MT4HT_UP	30286.846497	32031.702514	227.146858
MT4HT_CT	30286.492862	32033.184917	227.147356
MT4HT_DN	30286.139226	32034.667320	227.147854
	ROLL(mrad)	PITCH(mrad)	YAW(mrad)
	0.58	1.55	1.01

NOTES: Coordinates for the device are in the FSCS(z) coordinate system.

(+X - axis) is East, (+Y - axis) is North, (+Z - axis) is Vertical elevation

+ve Roll is cw rotation about the +Y-axis

+ve Pitch is the Vertical angle above the X-Y plane

+ve Yaw is the cw rotation about the +ve Z-axis

MT4Q4 FRD#11668

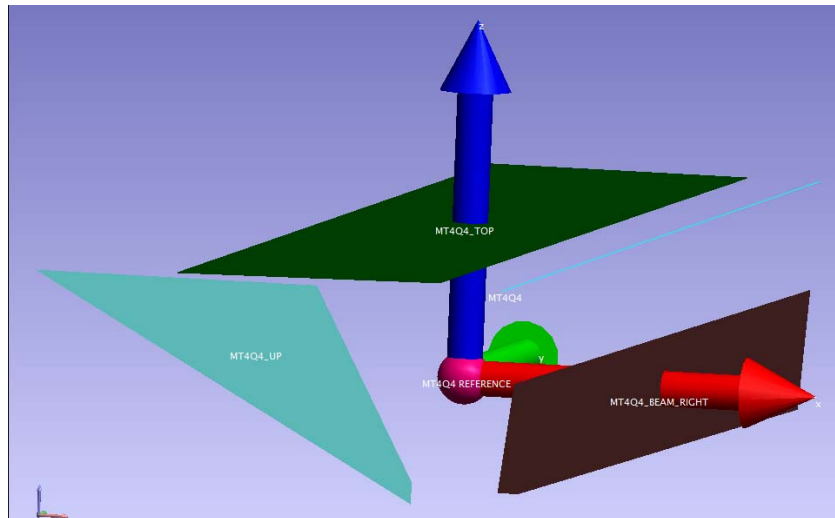

FRD11668
13- INCH HIGH
17- INCH WIDE
120- INCH LONG

MT4Q4 REFERENCE VALUES						
Point Name	X	Y	Z	X	Y	Z
	[Inches]	[Inches]	[Inches]	[Metres]	[Metres]	[Metres]
MT4Q4_UP	0.000	-60.000	0.000	0.00000	-1.52400	0.00000
MT4Q4_CT	0.000	0.000	0.000	0.00000	0.00000	0.00000
MT4Q4_DN	0.000	60.000	0.000	0.00000	1.52400	0.00000
MT4Q4_TOP	0.000	0.000	6.500	0.00000	0.00000	0.16510
MT4Q4_BEAM_RIGHT	8.500	0.000	0.000	0.21590	0.00000	0.00000

As-sets are shown relative to the Ideal Beam Sheet Position (Site coordinates for beam line: MTEST_r8.ces)

MT4Q4 ACTUALS AS-SET LOCAL						
Point Name	X	Y	Z	X	Y	Z
	[Inches]	[Inches]	[Inches]	[Metres]	[Metres]	[Metres]
MT4Q4_UP	-0.012	-0.046	-0.002	-0.00030	-0.00117	-0.00005
MT4Q4_CT	-0.003	59.953	-0.001	-0.00008	1.52281	-0.00003
MT4Q4_DN	0.006	119.953	0.000	0.00015	3.04681	0.00000
	ROLL(mrad)	PITCH(mrad)	YAW(mrad)			
	-0.05	0.02	0.15			

MT4Q4 ACTUALS AS-SET FSCS(Z)			
Point Name	X	Y	Z
	[Metres]	[Metres]	[Metres]
MT4Q4_UP	30271.363706	32094.367338	227.291011
MT4Q4_CT	30270.986919	32095.844011	227.294906
MT4Q4_DN	30270.610130	32097.320693	227.298801
	ROLL(mrad)	PITCH(mrad)	YAW(mrad)
	-0.05	0.02	0.15

NOTES: Coordinates for the device are in the FSCS(z) coordinate system.

(+X - axis) is East, (+Y - axis) is North, (+Z - axis) is Vertical elevation

+ve Roll is cw rotation about the +Y-axis

+ve Pitch is the Vertical angle above the X-Y plane

+ve Yaw is the cw rotation about the +ve Z-axis

MT4CH2 FRD#50094

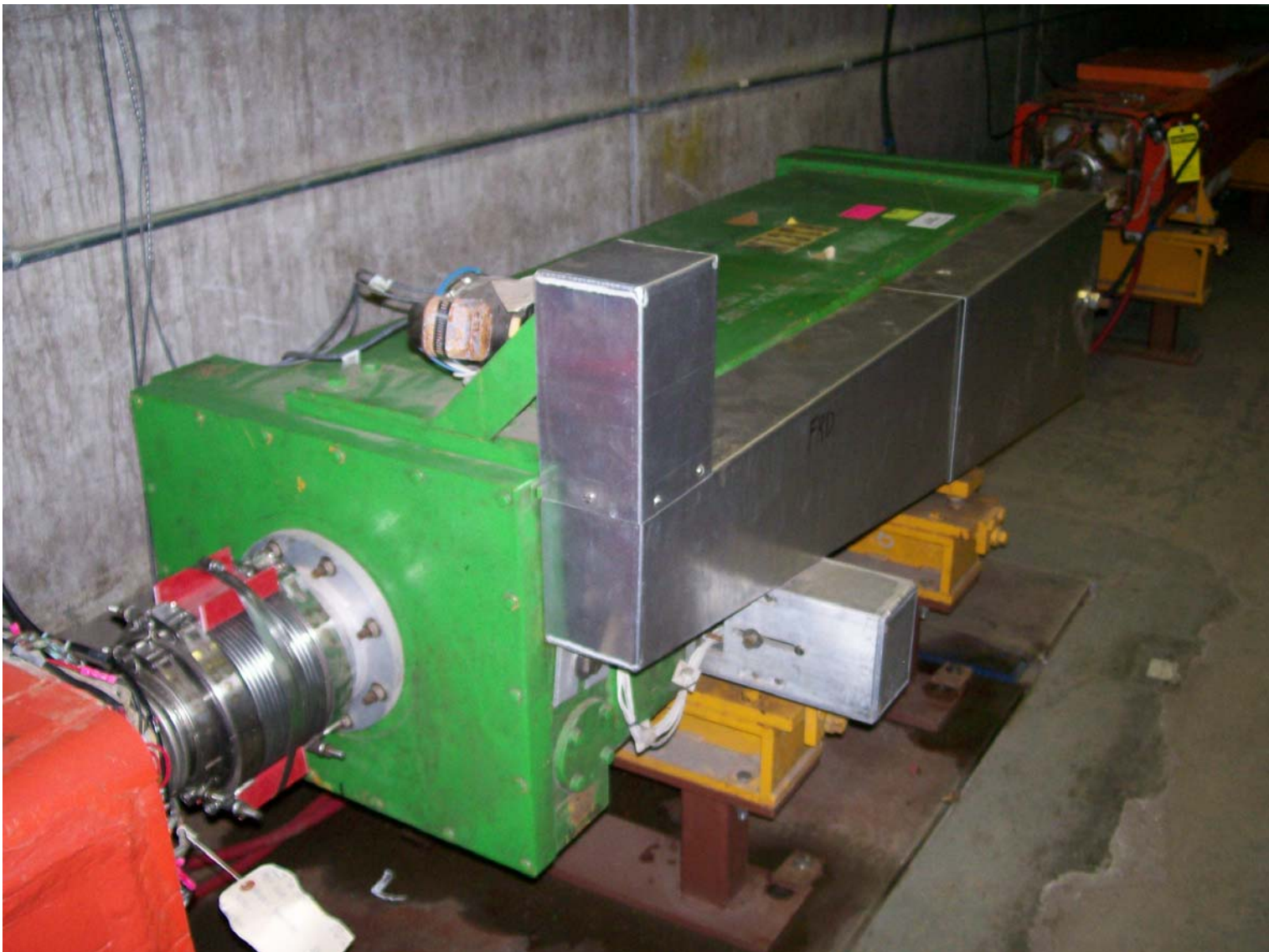
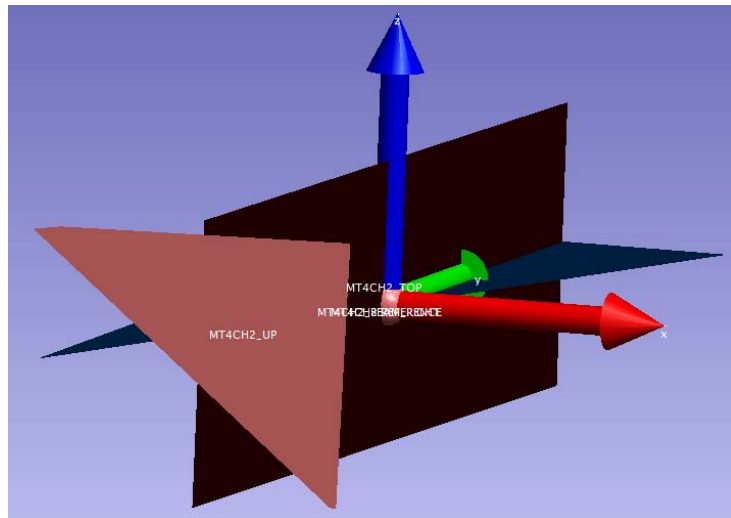

MT4CH2 UPSTREAM – BEAM RIGHT VIEW (Looking Downstream)



MT4CH2 DOWNSTREAM – BEAM LEFT VIEW (Looking Upstream)

FRD50094
 67.5-INCH LONG

Note: Beam sheet length is 59.055"

MT4CH2 REFERENCE VALUES						
Point Name	X	Y	Z	X	Y	Z
	[Inches]	[Inches]	[Inches]	[Metres]	[Metres]	[Metres]
MT4CH2_TOP_UP_BEAM_LEFT	0.000	-33.750	8.269	0.00000	-0.85725	0.21003
MT4CH2_TOP_DN_BEAM_LEFT	0.000	33.750	8.160	0.00000	0.85725	0.20726
MT4CH2_TOP_DN_BEAM_RIGHT	0.000	33.750	8.197	0.00000	0.85725	0.20820
MT4CH2_DN_BEAM_RIGHT_TOP	10.069	33.750	0.000	0.25575	0.85725	0.00000
MT4CH2_DN_BEAM_RIGHT_BOTTOM	10.046	33.750	0.000	0.25517	0.85725	0.00000
MT4CH2_UP_BEAM_RIGHT_BOTTOM	10.094	-33.750	0.000	0.25639	-0.85725	0.00000
MT4CH2_UP_BEAM_RIGHT_TOP	10.124	-33.750	0.000	0.25715	-0.85725	0.00000
MT4CH2_UP	0.000	-33.750	0.000	0.00000	-0.85725	0.00000
MT4CH2_CT	0.000	0.000	0.000	0.00000	0.00000	0.00000
MT4CH2_DN	0.000	33.750	0.000	0.00000	0.85725	0.00000

As-sets are shown relative to the Ideal Beam Sheet Position (Site coordinates for beam line: MTEST_r8.ces)

MT4CH2 ACTUALS AS-SET LOCAL						
Point Name	X	Y	Z	X	Y	Z
	[Inches]	[Inches]	[Inches]	[Metres]	[Metres]	[Metres]
MT4CH2_UP	0.004	0.122	-0.004	0.00010	0.00310	-0.00010
MT4CH2_CT	-0.003	33.872	0.003	-0.00008	0.86035	0.00008
MT4CH2_DN	-0.009	67.622	0.009	-0.00023	1.71760	0.00023
	ROLL(mrad)	PITCH(mrad)	YAW(mrad)			
	0.41	0.20	-0.18			

MT4CH2 ACTUALS AS-SET FSCS(Z)			
Point Name	X	Y	Z
	[Metres]	[Metres]	[Metres]
MT4CH2_UP	30270.517270	32097.684145	227.299650
MT4CH2_CT	30270.305051	32098.514709	227.302002
MT4CH2_DN	30270.092832	32099.345272	227.304353
	ROLL(mrad)	PITCH(mrad)	YAW(mrad)
	0.41	0.20	-0.18

NOTES: Coordinates for the device are in the FSCS(z) coordinate system.

(+X - axis) is East, (+Y - axis) is North, (+Z - axis) is Vertical elevation

+ve Roll is cw rotation about the +Y-axis

+ve Pitch is the Vertical angle above the X-Y plane

+ve Yaw is the cw rotation about the +ve Z-axis

MT4Q5 FRD#10312

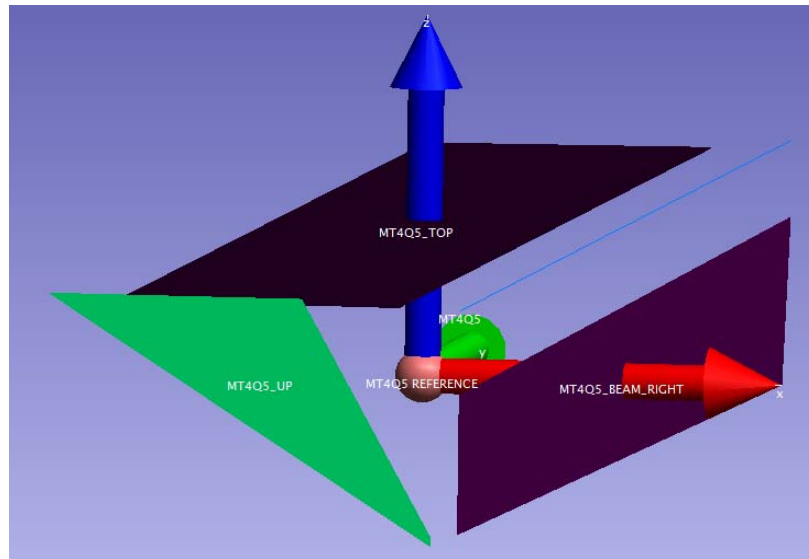

MT4Q5 UPSTREAM – BEAM RIGHT VIEW

FRD10132
13- INCH HIGH
17- INCH WIDE
120- INCH LONG

MT4Q5 REFERENCE VALUES						
Point Name	X	Y	Z	X	Y	Z
	[Inches]	[Inches]	[Inches]	[Metres]	[Metres]	[Metres]
MT4Q5_UP	0.000	-60.000	0.000	0.00000	-1.52400	0.00000
MT4Q5_CT	0.000	0.000	0.000	0.00000	0.00000	0.00000
MT4Q5_DN	0.000	60.000	0.000	0.00000	1.52400	0.00000
MT4Q5_TOP	0.000	0.000	6.500	0.00000	0.00000	0.16510
MT4Q5_BEAM_RIGHT	8.500	0.000	0.000	0.21590	0.00000	0.00000

As-sets are shown relative to the Ideal Beam Sheet Position (Site coordinates for beam line: MTEST_r8.ces)

MT4Q5 ACTUALS AS-SET LOCAL						
Point Name	X	Y	Z	X	Y	Z
	[Inches]	[Inches]	[Inches]	[Metres]	[Metres]	[Metres]
MT4Q5_UP	-0.002	0.147	-0.006	-0.00005	0.00373	-0.00015
MT4Q5_CT	0.001	60.147	-0.002	0.00003	1.52774	-0.00005
MT4Q5_DN	0.004	120.147	0.002	0.00010	3.05174	0.00005
	ROLL(mrad)	PITCH(mrad)	YAW(mrad)			
	0.41	0.07	0.05			

MT4Q5 ACTUALS AS-SET FSCS(Z)			
Point Name	X	Y	Z
	[Metres]	[Metres]	[Metres]
MT4Q5_UP	30269.779306	32100.573990	227.307187
MT4Q5_CT	30269.402371	32102.050635	227.311157
MT4Q5_DN	30269.025436	32103.527280	227.315127
	ROLL(mrad)	PITCH(mrad)	YAW(mrad)
	0.41	0.07	0.05

NOTES: Coordinates for the device are in the FSCS(z) coordinate system.

(+X - axis) is East, (+Y - axis) is North, (+Z - axis) is Vertical elevation

+ve Roll is cw rotation about the +Y-axis

+ve Pitch is the Vertical angle above the X-Y plane

+ve Yaw is the cw rotation about the +ve Z-axis

MT4CV2 FRD#50034

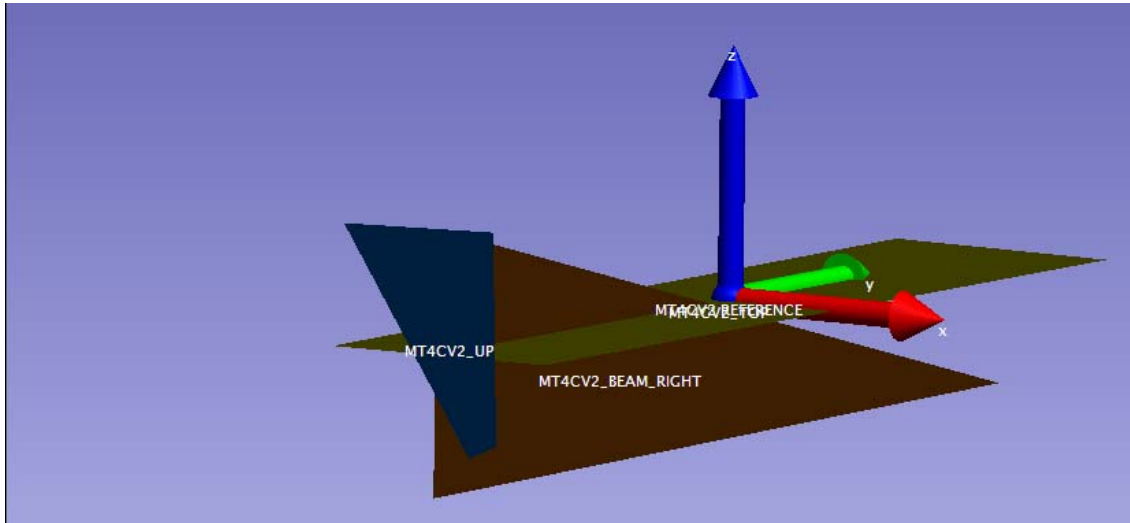

MT4CV2 UPSTREAM –BEAM RIGHT VIEW

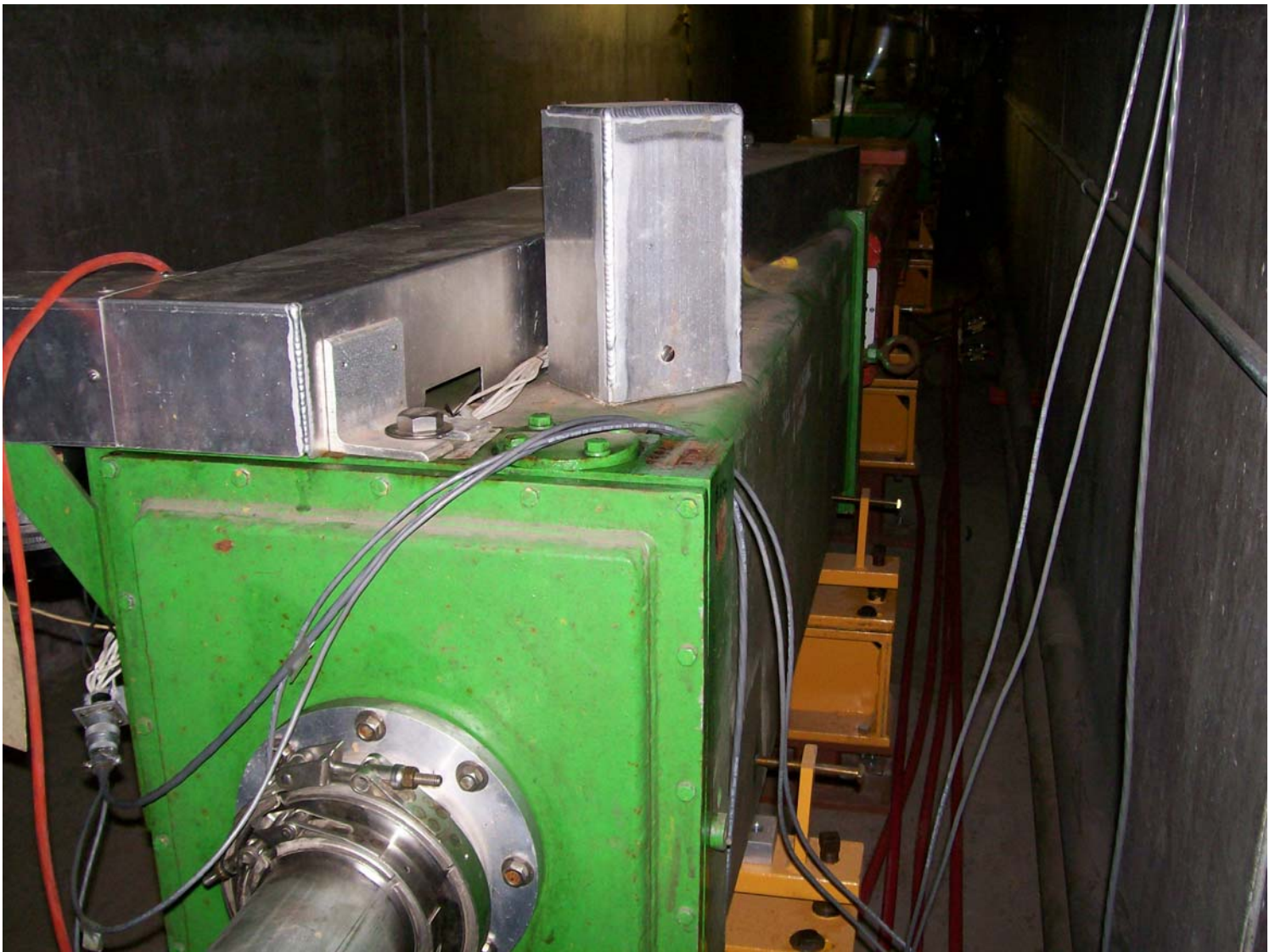

MT4CV2 DOWNSTREAM –BEAM LEFT VIEW

FRD50034

67.5 INCHES LONG

NOTE: LENGTH ON BEAM SHEET IS 59.055"

MT4CV2 [50034] REFERENCE VALUES						
Point Name	X	Y	Z	X	Y	Z
	[Inches]	[Inches]	[Inches]	[Metres]	[Metres]	[Metres]
50034_UP_TOP_BEAM_RIGHT	7.626	-31.310	10.034	0.19370	-0.79528	0.25486
50034_UP_TOP_BEAM_LEFT	-6.963	-31.715	10.056	-0.17686	-0.80556	0.25542
50034_DN_TOP_BEAM_LEFT	-7.230	28.778	9.992	-0.18364	0.73096	0.25380
50034_DN_TOP_BEAM_RIGHT	7.721	28.529	9.970	0.19611	0.72464	0.25324
50034_UP_BEAM_RIGHT_TOP	8.315	-31.351	7.393	0.21120	-0.79632	0.18778
50034_UP_BEAM_RIGHT_BOTTOM	8.310	-31.542	-8.469	0.21107	-0.80117	-0.21511
50034_DN_BEAM_RIGHT_BOTTOM	8.265	28.713	-7.916	0.20993	0.72931	-0.20107
50034_UP	0.000	-33.750	-0.000	0.00000	-0.85725	0.00000
50034_CT	0.000	0.000	0.000	0.00000	0.00000	0.00000
50034_DN	0.000	33.750	0.000	0.00000	0.85725	0.00000

As-sets are shown relative to the Ideal Beam Sheet Position (Site coordinates for beam line: MTEST_r8.ces)

MT4CV2 [50034] ACTUALS AS-SET LOCAL						
Point Name	X	Y	Z	X	Y	Z
	[Inches]	[Inches]	[Inches]	[Metres]	[Metres]	[Metres]
MT4CV2_UP	-0.011	-1.025	-0.001	-0.00003	-3.41510	-0.00016
MT4CV2_CT	-0.007	32.725	0.002	0.00003	-1.89110	-0.00006
MT4CV2_DN	-0.004	66.475	0.005	0.00010	-0.36710	0.00004
	ROLL(mrad)	PITCH(mrad)	YAW(mrad)			
	0.36	0.10	0.10			

MT4CV2 [50034] ACTUALS AS-SET FSCS(Z)			
Point Name	X	Y	Z
	[Metres]	[Metres]	[Metres]
MT4CV2_UP	30268.940710	32103.857646	227.315921
MT4CV2_CT	30268.728731	32104.688271	227.318180
MT4CV2_DN	30268.516752	32105.518895	227.320439
	ROLL(mrad)	PITCH(mrad)	YAW(mrad)
	0.36	0.10	0.10

NOTES: Coordinates for the device are in the FSCS(z) coordinate system.

(+X - axis) is East, (+Y - axis) is North, (+Z - axis) is Vertical elevation

+ve Roll is cw rotation about the +Y-axis

+ve Pitch is the Vertical angle above the X-Y plane

+ve Yaw is the cw rotation about the +ve Z-axis

MT4Q6 FRD#11671

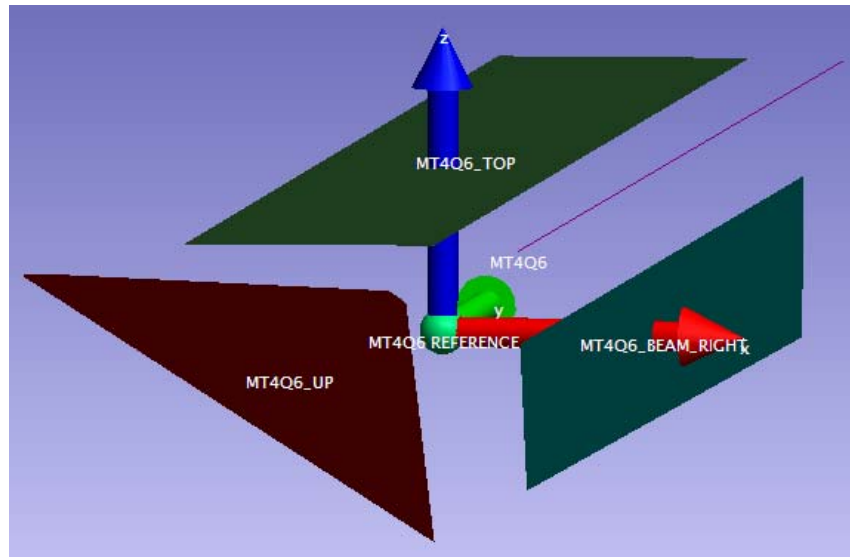

FRD11671
13- INCH HIGH
17 -INCH WIDE
120- INCH LONG

MT4Q6 REFERENCE VALUES						
Point Name	X	Y	Z	X	Y	Z
	[Inches]	[Inches]	[Inches]	[Metres]	[Metres]	[Metres]
MT4Q6_UP	0.000	-60.000	0.000	0.00000	-1.52400	0.00000
MT4Q6_CT	0.000	0.000	0.000	0.00000	0.00000	0.00000
MT4Q6_DN	0.000	60.000	0.000	0.00000	1.52400	0.00000
MT4Q6_TOP	0.000	0.000	6.500	0.00000	0.00000	0.16510
MT4Q6_BEAM_RIGHT	8.500	0.000	0.000	0.21590	0.00000	0.00000

As-sets are shown relative to the Ideal Beam Sheet Position (Site coordinates for beam line: MTEST_r8.ces)

MT4Q6 ACTUALS AS-SET LOCAL						
Point Name	X	Y	Z	X	Y	Z
	[Inches]	[Inches]	[Inches]	[Metres]	[Metres]	[Metres]
MT4Q6_UP	-0.012	-0.462	-0.003	-0.00030	-0.01173	-0.00008
MT4Q6_CT	-0.004	59.538	-0.002	-0.00010	1.51227	-0.00005
MT4Q6_DN	0.004	119.538	-0.001	0.00010	3.03627	-0.00003
	ROLL(mrad)	PITCH(mrad)	YAW(mrad)			
	-0.14	0.02	0.14			

MT4Q6 ACTUALS AS-SET FSCS(Z)			
Point Name	X	Y	Z
	[Metres]	[Metres]	[Metres]
MT4Q6_UP	30268.109215	32107.114240	227.324409
MT4Q6_CT	30267.732412	32108.590907	227.328312
MT4Q6_DN	30267.355606	32110.067585	227.332215
	ROLL(mrad)	PITCH(mrad)	YAW(mrad)
	-0.14	0.02	0.14

NOTES: Coordinates for the device are in the FSCS(z) coordinate system.

(+X - axis) is East, (+Y - axis) is North, (+Z - axis) is Vertical elevation

+ve Roll is cw rotation about the +Y-axis

+ve Pitch is the Vertical angle above the X-Y plane

+ve Yaw is the cw rotation about the +ve Z-axis

MT5FP1 [6301201] AS-FOUND

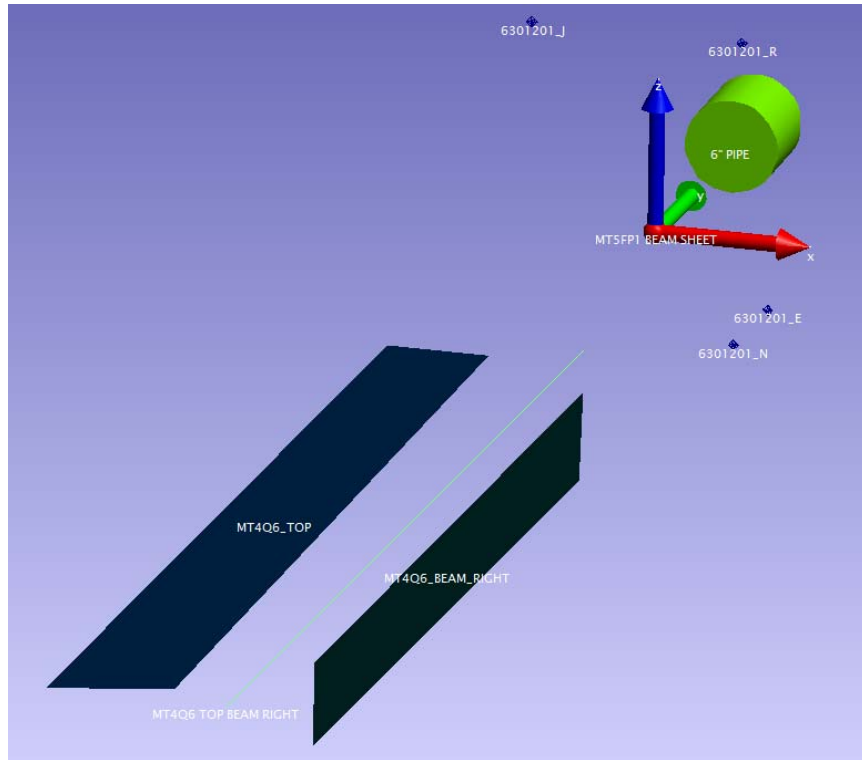

UPSTREAM VIEW



DOWNSTREAM VIEW



BEAM RIGHT VIEW

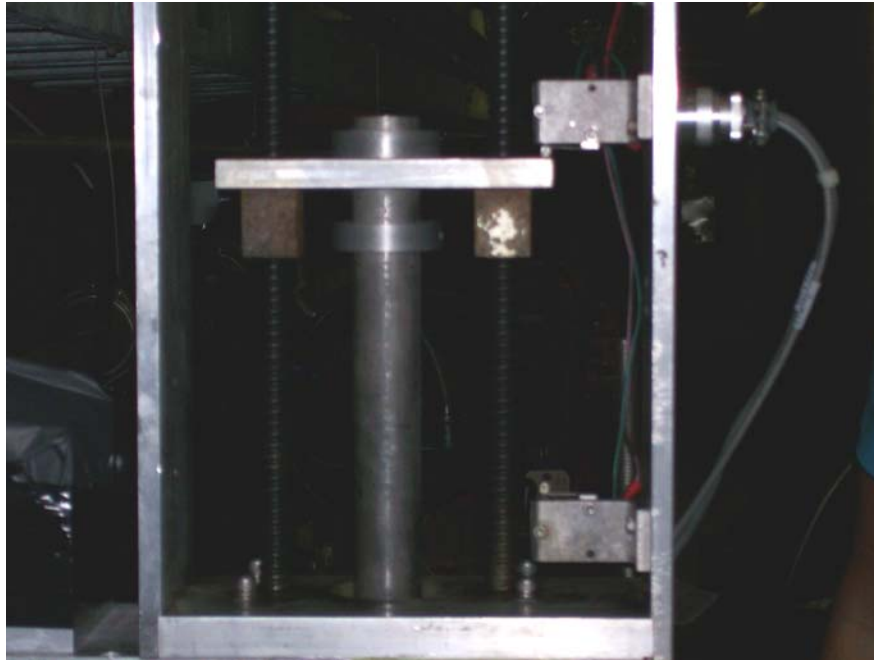

ISSUE WITH COLLAR SLIPPING

Reference File located in: G:\projects\7013\fpm\6301201

MT5FP1 [6301201] REFERENCE VALUES						
Point Name	X	Y	Z	X	Y	Z
	[Inches]	[Inches]	[Inches]	[Metres]	[Metres]	[Metres]
6301201_A	6.810	-4.987	14.018	0.17297	-0.12667	0.35606
6301201_D	6.699	-4.985	-5.448	0.17015	-0.12662	-0.13838
6301201_E	-6.742	-4.984	-5.414	-0.17125	-0.12659	-0.13752
6301201_H	-6.668	-4.975	14.030	-0.16937	-0.12637	0.35636
6301201_J	6.848	2.671	14.103	0.17394	0.06784	0.35822
6301201_M	6.717	2.707	-5.471	0.17061	0.06876	-0.13896
6301201_N	-6.669	2.696	-5.379	-0.16939	0.06848	-0.13663
6301201_R	-6.603	2.684	14.198	-0.16772	0.06817	0.36063
6301201_UP	0.000	-4.984	0.000	0.00000	-0.12659	0.00000
6301201_CT	0.000	0.000	0.000	0.00000	0.00000	0.00000
6301201_DN	0.000	2.701	0.000	0.00000	0.06861	0.00000

As-sets are shown relative to the Ideal Beam Sheet Position (Site coordinates for beam line: MTEST_r8.ces)

**NOTE: COMPONENT IS ROTATED 180 DEGREES IN TUNNEL. IMPORT FRAME FOR REFERENCE VALUES HAS (+Y) POINTING UPSTREAM.
COULD NOT ADJUST COMPONENT DUE TO STAND DESIGN – ASFOUND ONLY**

MT5FP1 [6301201] ACTUALS AS-FOUND LOCAL						
Point Name	X	Y	Z	X	Y	Z
	[Inches]	[Inches]	[Inches]	[Metres]	[Metres]	[Metres]
6301201_UP	-0.117	-2.038	0.149	-0.00612	-0.05179	0.00437
6301201_CT	-0.161	-2.038	0.157	-0.00409	-0.05177	0.00399
6301201_DN	-0.241	-2.039	0.172	-0.00297	-0.05177	0.00378
	ROLL(mrad)	PITCH(mrad)	YAW(mrad)			
	14.8	-2.99	-16.3			

MT5FP1 [6301201] ACTUALS AS-FOUND FSCS(Z)			
Point Name	X	Y	Z
	[Metres]	[Metres]	[Metres]
6301201_UP	30267.286043	32110.327641	227.336724
6301201_CT	30267.267995	32110.393833	227.337099
6301201_DN	30267.234696	32110.515963	227.337791
	ROLL(mrad)	PITCH(mrad)	YAW(mrad)
	14.8	-2.99	-16.3

MT5FP1 BEAM PIPE DOWNSTREAM ACTUALS AS-FOUND LOCAL						
Point Name	X	Y	Z	X	Y	Z
	[Inches]	[Inches]	[Inches]	[Metres]	[Metres]	[Metres]
6" _BEAM_PIPE_UP	-0.438	18.350	0.124	-0.01113	0.46609	0.00315
6" _BEAM_PIPE_CT	-0.488	21.185	0.159	-0.01240	0.53810	0.00404
6" _BEAM_PIPE_DN	-0.539	24.020	0.195	-0.01369	0.61011	0.00495

NOTES: Coordinates for the device are in the FSCS(z) coordinate system.

(+X - axis) is East, (+Y - axis) is North, (+Z - axis) is Vertical elevation

+ve Roll is cw rotation about the +Y-axis

+ve Pitch is the Vertical angle above the X-Y plane

+ve Yaw is the cw rotation about the +ve Z-axis

MT5 BEAM PIPE – MT5SC – MT5CON

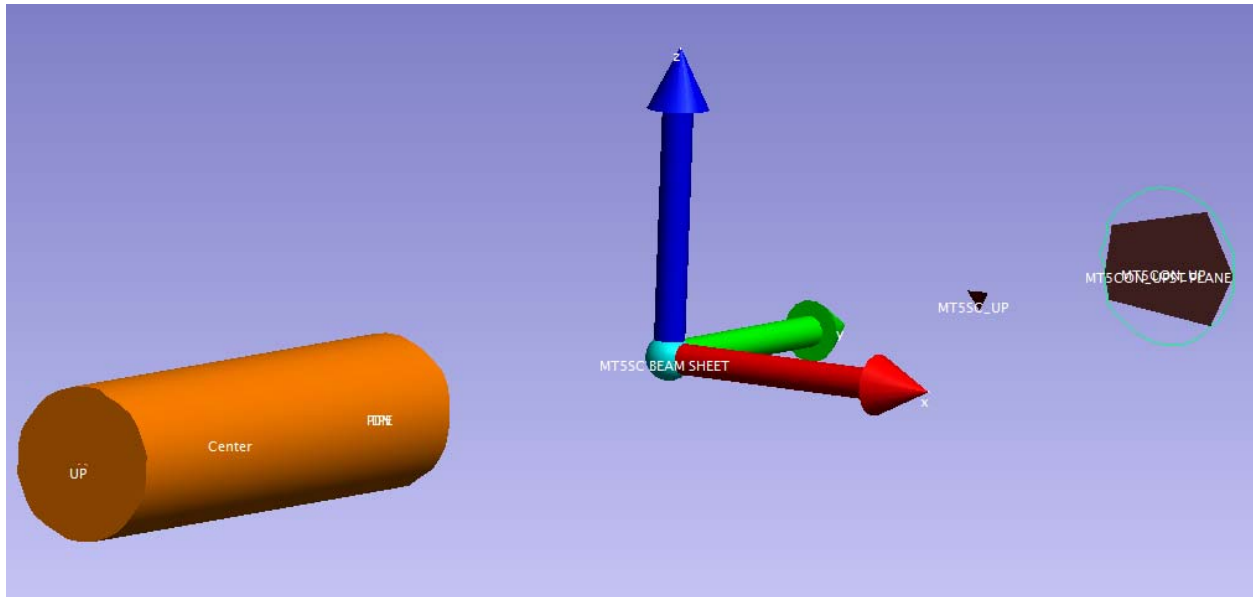

BEAM PIPE – SCINTILLATOR – TARGET WHEEL

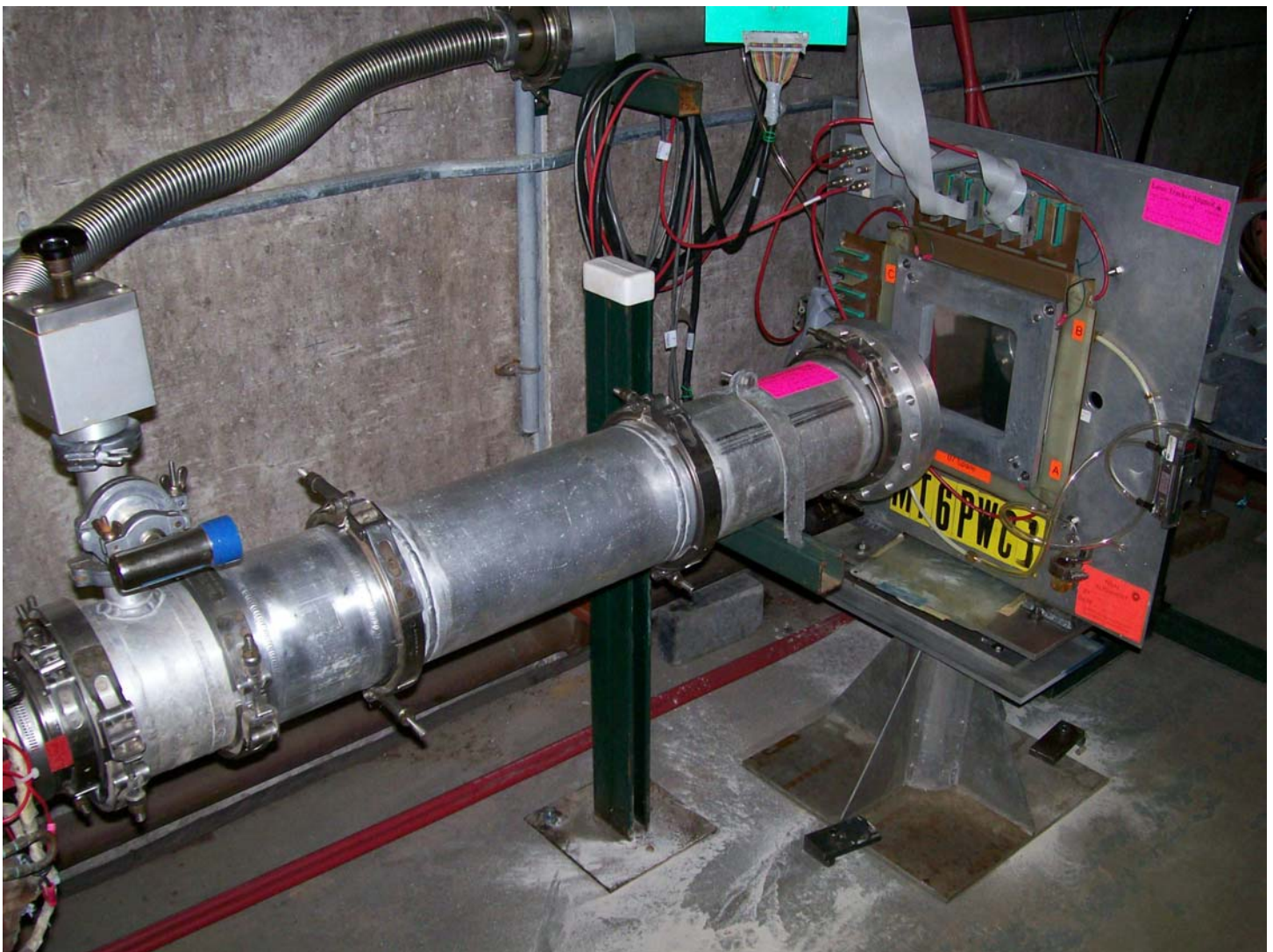

MT5PWC1

This picture is prior to MT5FP1 installation.



MT5SC and MT5CON

This picture is prior to MT5FP1 installation.

As-sets are shown relative to the Ideal Beam Sheet Position (Site coordinates for beam line: MTEST_r8.ces)

MT5BEAMPIPE ACTUALS AS-SET LOCAL (6" Diameter)						
Point Name	X [Inches]	Y [Inches]	Z [Inches]	X [Metres]	Y [Metres]	Z [Metres]
MT5BEAMPIPE_UP	-0.013	0.000	0.023	-0.00033	0.00000	0.00058
MT5BEAMPIPE_CT	-0.010	10.379	-0.016	-0.00025	0.26363	-0.00041
MT5BEAMPIPE_DN	-0.007	20.758	-0.055	-0.00018	0.52725	-0.00140
	ROLL(mrad)	PITCH(mrad)	YAW(mrad)			
		-3.76	0.29			

MT5BEAMPIPE ACTUALS AS-SET FSCS (Z)			
Point Name	X [Metres]	Y [Metres]	Z [Metres]
MT5BEAMPIPE_UP	30267.265266	32110.419728	227.333743
MT5BEAMPIPE_CT	30267.200119	32110.675187	227.333427
MT5BEAMPIPE_DN	30267.134971	32110.930645	227.333112
	ROLL(mrad)	PITCH(mrad)	YAW(mrad)
		-3.76	0.29

MT5SC ACTUALS AS-SET LOCAL						
Point Name	X	Y	Z	X	Y	Z
	[Inches]	[Inches]	[Inches]	[Metres]	[Metres]	[Metres]
MT5SC_UP	0.056	21.107	0.092	0.00142	0.53612	0.00234

MT5SC ACTUALS AS-SET FSCS(Z)			
Point Name	X	Y	Z
	[Metres]	[Metres]	[Metres]
MT5SC_UP	30266.882053	32111.927692	227.339444

MT5CON ACTUALS AS-SET LOCAL						
Point Name	X	Y	Z	X	Y	Z
	[Inches]	[Inches]	[Inches]	[Metres]	[Metres]	[Metres]
MT5CON_UP	0.090	10.011	-0.027	0.00229	0.25428	-0.00069

MT5CON ACTUALS AS-SET FSCS(Z)			
Point Name	X	Y	Z
	[Metres]	[Metres]	[Metres]
MT5CON_UP	30266.801810	32112.245502	227.337276

NOTES: Coordinates for the device are in the FSCS(z) coordinate system.

(+X - axis) is East, (+Y - axis) is North, (+Z - axis) is Vertical elevation

+ve Roll is cw rotation about the +Y-axis

+ve Pitch is the Vertical angle above the X-Y plane

+ve Yaw is the cw rotation about the +ve Z-axis

BEAMPIPE: CYLINDER FIT FOR HORIZONTAL AND VERTICAL ONLY

MT5SC: PLANE FIT FOR STATIONING ONLY

MT5CON: CIRCLE FIT

NOTE: THESE WERE MOVED ON 06-JULY-07 WHEN THE MT5FP1 WAS INSTALLED. THESE COMPONENTS WERE NOT ASFOUND! THUS THESE VALUES ARE NO LONGER VALID!

MT5VT1 FRD#11647

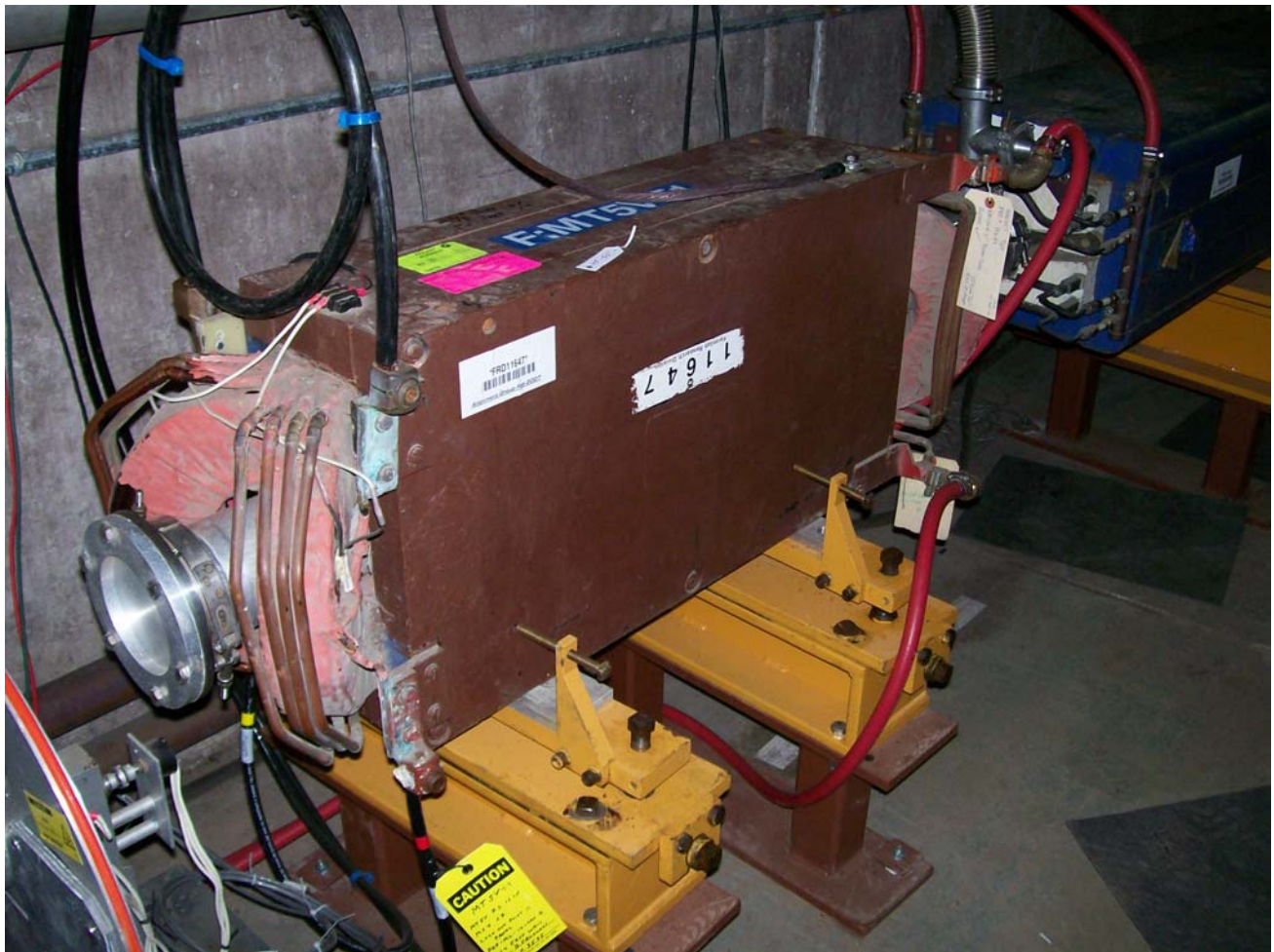
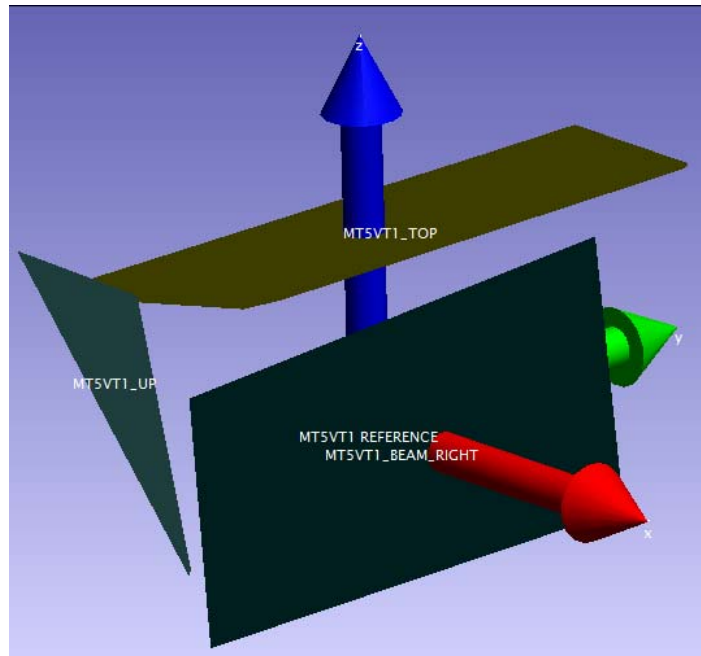

FRD11647
16 INCH HIGH
8.375 INCH WIDE
30 INCH LONG

MT5VT1 REFERENCE VALUES						
Point Name	X	Y	Z	X	Y	Z
	[Inches]	[Inches]	[Inches]	[Metres]	[Metres]	[Metres]
MT5VT1_UP	0.000	-15.000	0.000	0.00000	-0.38100	0.00000
MT5VT1_CT	0.000	0.000	0.000	0.00000	0.00000	0.00000
MT5VT1_DN	-0.000	15.000	0.000	0.00000	0.38100	0.00000
MT5VT1_TOP	0.000	0.000	8.000	0.00000	0.00000	0.20320
MT5VT1_BEAM_RIGHT	4.187	0.000	0.000	0.10635	0.00000	0.00000

As-sets are shown relative to the Ideal Beam Sheet Position (Site coordinates for beam line: MTEST_r8.ces)

MT5VT1 ACTUALS AS-SET LOCAL						
Point Name	X	Y	Z	X	Y	Z
	[Inches]	[Inches]	[Inches]	[Metres]	[Metres]	[Metres]
MT5VT1_UP	-0.004	-0.055	-0.041	-0.00010	-0.00140	-0.00104
MT5VT1_CT	0.005	14.945	-0.019	0.00013	0.37960	-0.00048
MT5VT1_DN	0.015	29.945	0.004	0.00038	0.76060	0.00010
	ROLL(mrad)	PITCH(mrad)	YAW(mrad)			
	1.27	1.52	0.64			

MT5VT1 ACTUALS AS-SET FSCS (Z)			
Point Name	X	Y	Z
	[Metres]	[Metres]	[Metres]
MT5VT1_UP	30266.711933	32112.587830	227.337806
MT5VT1_CT	30266.617923	32112.957038	227.339349
MT5VT1_DN	30266.523910	32113.326254	227.340892
	ROLL(mrad)	PITCH(mrad)	YAW(mrad)
	1.27	1.52	0.64

NOTES: Coordinates for the device are in the FSCS(z) coordinate system.

(+X - axis) is East, (+Y - axis) is North, (+Z - axis) is Vertical elevation

+ve Roll is cw rotation about the +Y-axis

+ve Pitch is the Vertical angle above the X-Y plane

+ve Yaw is the cw rotation about the +ve Z-axis

MT5E1 – FRD#11445

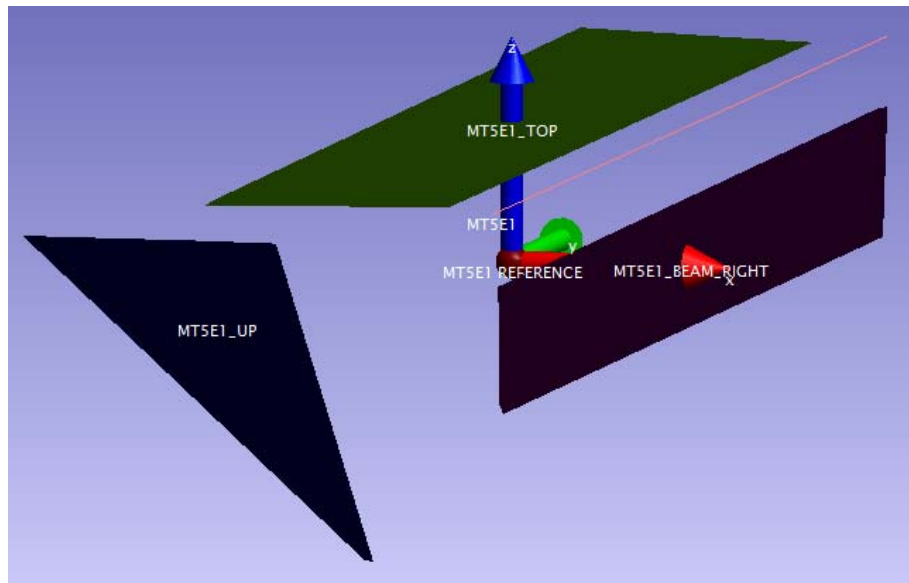

FRD11445
HORIZONTAL CORRECTION = 8"
VERTICAL CORRECTION = 6.25"
STATION CORRECTION = 60"

MT5E1 REFERENCE VALUES						
Point Name	X	Y	Z	X	Y	Z
	[Inches]	[Inches]	[Inches]	[Metres]	[Metres]	[Metres]
MT5E1_UP	0.000	-60.000	0.000	0.00000	-1.52400	0.00000
MT5E1_CT	0.000	0.000	0.000	0.00000	0.00000	0.00000
MT5E1_DN	0.000	60.000	0.000	0.00000	1.52400	0.00000
MT5E1_TOP	0.000	0.000	6.250	0.00000	0.00000	0.15875
MT5E1_BEAM_RIGHT	8.000	0.000	0.000	0.20320	0.00000	0.00000

As-sets are shown relative to the Ideal Beam Sheet Position (Site coordinates for beam line: MTEST_r8.ces)

MT5E1 ACTUALS AS-SET LOCAL						
Point Name	X	Y	Z	X	Y	Z
	[Inches]	[Inches]	[Inches]	[Metres]	[Metres]	[Metres]
MT5E1_UP	0.001	-0.317	0.009	0.00003	-0.00805	0.00023
MT5E1_CT	-0.001	59.683	0.008	-0.00003	1.51595	0.00020
MT5E1_DN	-0.002	119.683	0.007	-0.00005	3.03995	0.00018
	ROLL(mrad)	PITCH(mrad)	YAW(mrad)			
	-0.02	-0.02	-0.02			

MT5E1 ACTUALS AS-SET FSCS(Z)			
Point Name	X	Y	Z
	[Metres]	[Metres]	[Metres]
MT5E1_UP	30266.405697	32113.787696	227.342235
MT5E1_CT	30266.035231	32115.265967	227.346081
MT5E1_DN	30265.664763	32116.744248	227.349926
	ROLL(mrad)	PITCH(mrad)	YAW(mrad)
	-0.02	-0.02	-0.02

NOTES: Coordinates for the device are in the FSCS(z) coordinate system.

(+X - axis) is East, (+Y - axis) is North, (+Z - axis) is Vertical elevation

+ve Roll is cw rotation about the +Y-axis

+ve Pitch is the Vertical angle above the X-Y plane

+ve Yaw is the cw rotation about the +ve Z-axis

MT5E2 FRD#11446

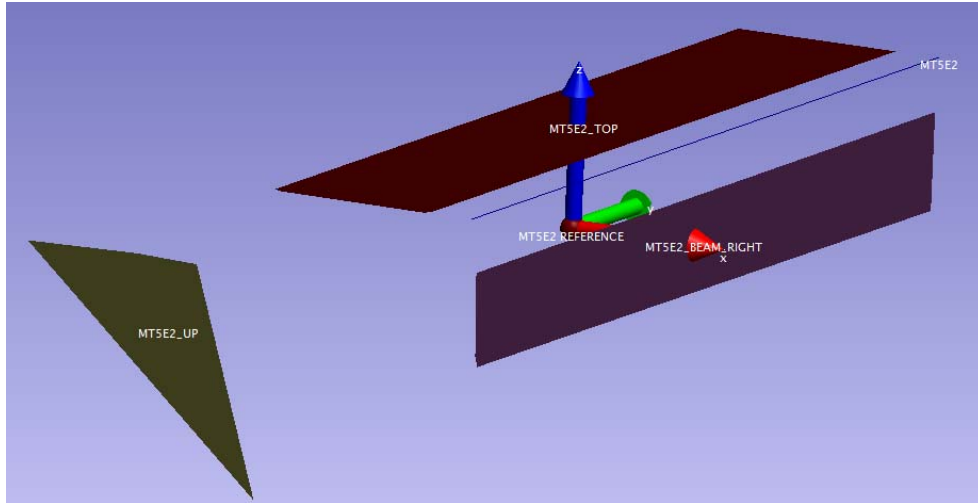

FRD#11446
H CORR = 8"
V CORR = 6.25"
STA CORR = 60"

MT5E2 REFERENCE VALUES						
Point Name	X	Y	Z	X	Y	Z
	[Inches]	[Inches]	[Inches]	[Metres]	[Metres]	[Metres]
MT5E2_UP	0.000	-60.000	0.000	0.00000	-1.52400	0.00000
MT5E2_CT	0.000	0.000	0.000	0.00000	0.00000	0.00000
MT5E2_DN	0.000	60.000	0.000	0.00000	1.52400	0.00000
MT5E2_TOP	0.000	0.000	6.250	0.00000	0.00000	0.15875
MT5E2_BEAM_RIGHT	8.000	0.000	0.000	0.20320	0.00000	0.00000

As-sets are shown relative to the Ideal Beam Sheet Position (Site coordinates for beam line: MTEST_r8.ces)

MT5E2 ACTUALS AS-SET LOCAL						
Point Name	X	Y	Z	X	Y	Z
	[Inches]	[Inches]	[Inches]	[Metres]	[Metres]	[Metres]
MT5E2_UP	0.006	0.072	0.009	0.00015	0.00183	0.00023
MT5E2_CT	0.002	60.072	0.006	0.00005	1.52583	0.00015
MT5E2_DN	-0.001	120.072	0.003	-0.00003	3.04983	0.00008
	ROLL(mrad)	PITCH(mrad)	YAW(mrad)			
	0.01	-0.05	-0.06			

MT5E2 ACTUALS AS-SET FSCS(Z)			
Point Name	X	Y	Z
	[Metres]	[Metres]	[Metres]
MT5E2_UP	30265.547263	32117.222910	227.351225
MT5E2_CT	30265.189921	32118.704422	227.355025
MT5E2_DN	30264.832580	32120.185931	227.358826
	ROLL(mrad)	PITCH(mrad)	YAW(mrad)
	0.01	-0.05	-0.06

NOTES: Coordinates for the device are in the FSCS(z) coordinate system.

(+X - axis) is East, (+Y - axis) is North, (+Z - axis) is Vertical elevation

+ve Roll is cw rotation about the +Y-axis

+ve Pitch is the Vertical angle above the X-Y plane

+ve Yaw is the cw rotation about the +ve Z-axis

MT5E3 FRD#11448

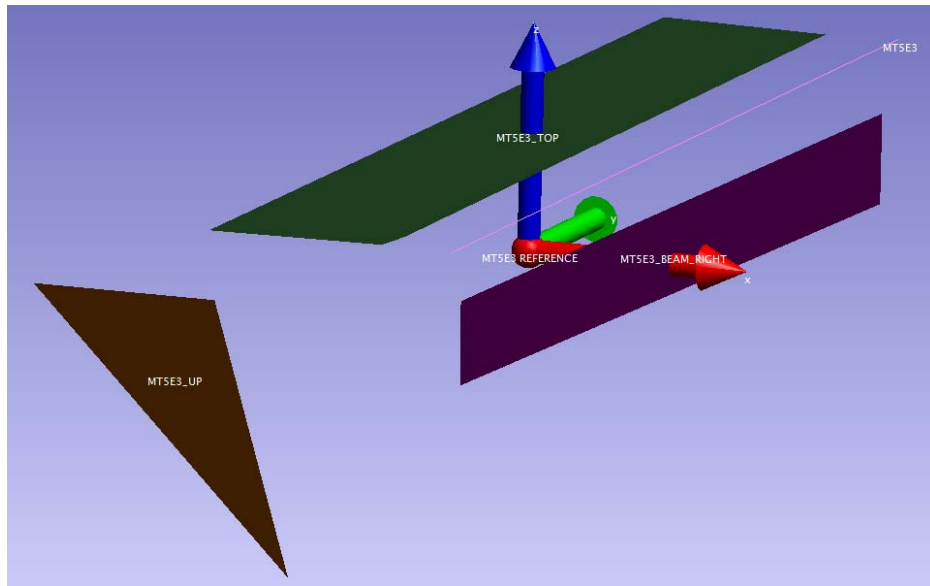

FRD#11448
H CORR = 8"
V CORR = 6.25"
STA CORR = 60"

MT5E3 REFERENCE VALUES						
Point Name	X	Y	Z	X	Y	Z
	[Inches]	[Inches]	[Inches]	[Metres]	[Metres]	[Metres]
MT5E3_UP	0.000	-60.000	0.000	0.00000	-1.52400	0.00000
MT5E3_CT	0.000	0.000	0.000	0.00000	0.00000	0.00000
MT5E3_DN	0.000	60.000	0.000	0.00000	1.52400	0.00000
MT5E3_TOP	0.000	0.000	6.250	0.00000	0.00000	0.15875
MT5E3_BEAM_RIGHT	8.000	0.000	0.000	0.20320	0.00000	0.00000

As-sets are shown relative to the Ideal Beam Sheet Position (Site coordinates for beam line: MTEST_r8.ces)

MT5E3 ACTUALS AS-SET LOCAL						
Point Name	X	Y	Z	X	Y	Z
	[Inches]	[Inches]	[Inches]	[Metres]	[Metres]	[Metres]
MT5E3_UP	-0.000	-0.534	0.006	0.00000	-0.01356	0.00015
MT5E3_CT	-0.009	59.465	0.000	-0.00023	1.51041	0.00000
MT5E3_DN	-0.017	119.465	-0.005	-0.00043	3.03442	-0.00013
	ROLL(mrad)	PITCH(mrad)	YAW(mrad)			
	0.82	-0.10	-0.14			

MT5E3 ACTUALS AS-SET FSCS(Z)			
Point Name	X	Y	Z
	[Metres]	[Metres]	[Metres]
MT5E3_UP	30264.724958	32120.640992	227.360090
MT5E3_CT	30264.380701	32122.125583	227.363820
MT5E3_DN	30264.036441	32123.610187	227.367550
	ROLL(mrad)	PITCH(mrad)	YAW(mrad)
	0.82	-0.10	-0.14

NOTES: Coordinates for the device are in the FSCS(z) coordinate system.

(+X - axis) is East, (+Y - axis) is North, (+Z - axis) is Vertical elevation

+ve Roll is cw rotation about the +Y-axis

+ve Pitch is the Vertical angle above the X-Y plane

+ve Yaw is the cw rotation about the +ve Z-axis

MT5E4 FRD#11449

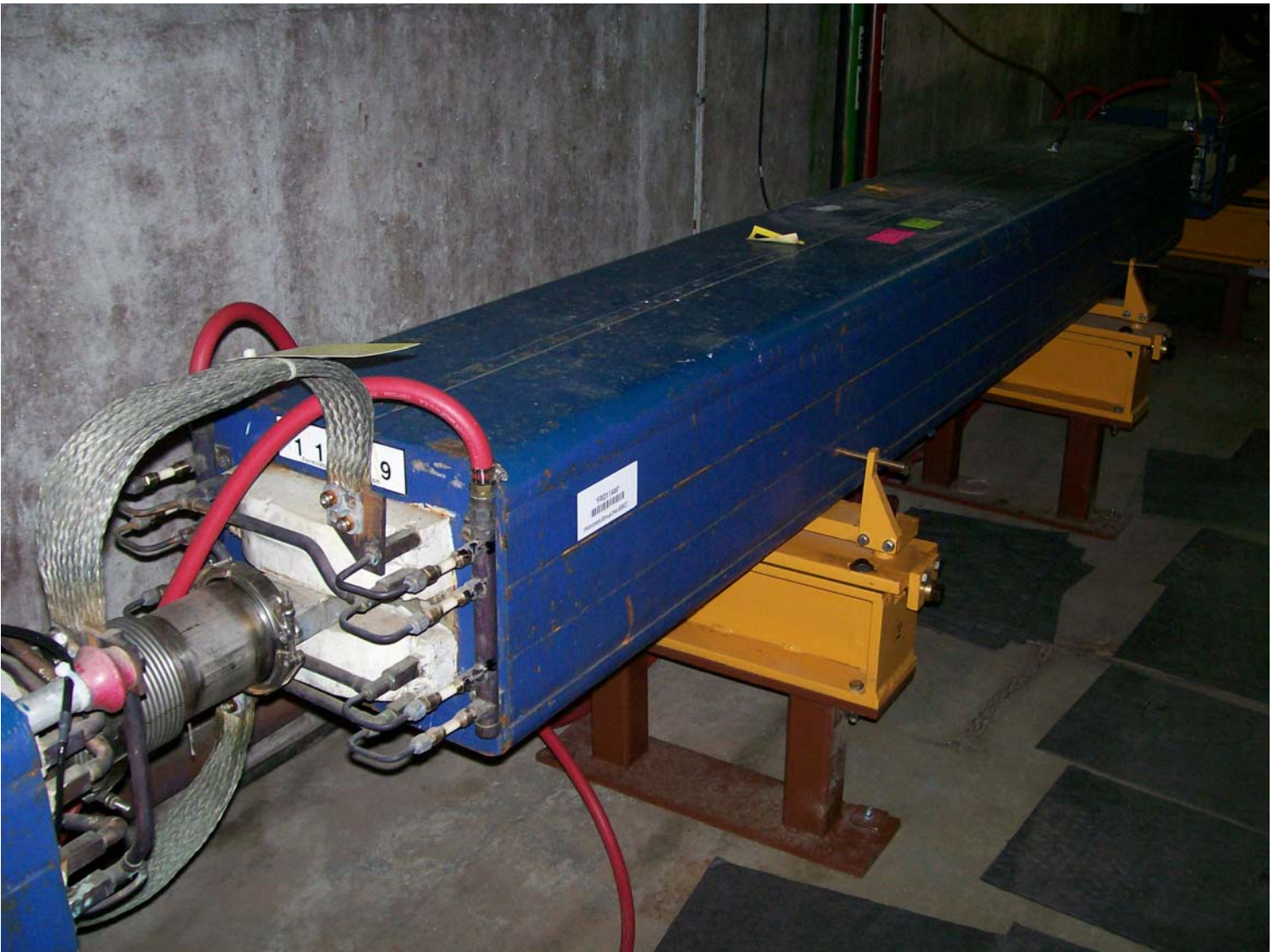
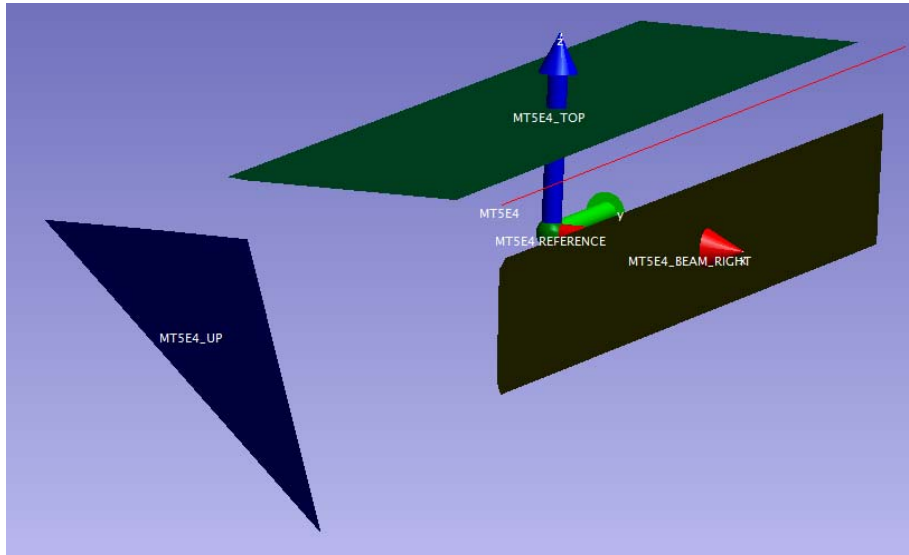

FRD 11449
HORZ. = 8.000"
VERT. = 6.25"
STA = 60.00

MT5E4 REFERENCE VALUES						
Point Name	X	Y	Z	X	Y	Z
	[Inches]	[Inches]	[Inches]	[Metres]	[Metres]	[Metres]
MT5E4_UP	0.000	-60.000	0.000	0.00000	-1.52400	0.00000
MT5E4_CT	0.000	0.000	0.000	0.00000	0.00000	0.00000
MT5E4_DN	0.000	60.000	0.000	0.00000	1.52400	0.00000
MT5E4_TOP	0.000	0.000	6.250	0.00000	0.00000	0.15875
MT5E4_BEAM_RIGHT	8.000	0.000	0.000	0.20320	0.00000	0.00000

As-sets are shown relative to the Ideal Beam Sheet Position (Site coordinates for beam line: MTEST_r8.ces)

MT5E4 ACTUALS AS-SET LOCAL						
Point Name	X	Y	Z	X	Y	Z
	[Inches]	[Inches]	[Inches]	[Metres]	[Metres]	[Metres]
MT5E4_UP	-0.002	-0.042	-0.003	-0.00005	-0.00107	-0.00008
MT5E4_CT	-0.003	59.958	-0.005	-0.00008	1.52294	-0.00013
MT5E4_DN	-0.004	119.958	-0.007	-0.00010	3.04694	-0.00018
	ROLL(mrad)	PITCH(mrad)	YAW(mrad)			
	0.07	-0.03	-0.02			

MT5E4 ACTUALS AS-SET FSCS(Z)			
Point Name	X	Y	Z
	[Metres]	[Metres]	[Metres]
MT5E4_UP	30263.927031	32124.093478	227.368869
MT5E4_CT	30263.596181	32125.581127	227.372690
MT5E4_DN	30263.265331	32127.068776	227.376510
	ROLL(mrad)	PITCH(mrad)	YAW(mrad)
	0.07	-0.03	-0.02

NOTES: Coordinates for the device are in the FSCS(z) coordinate system.

(+X - axis) is East, (+Y - axis) is North, (+Z - axis) is Vertical elevation

+ve Roll is cw rotation about the +Y-axis

+ve Pitch is the Vertical angle above the X-Y plane

+ve Yaw is the cw rotation about the +ve Z-axis

MT5E5 FRD#10532

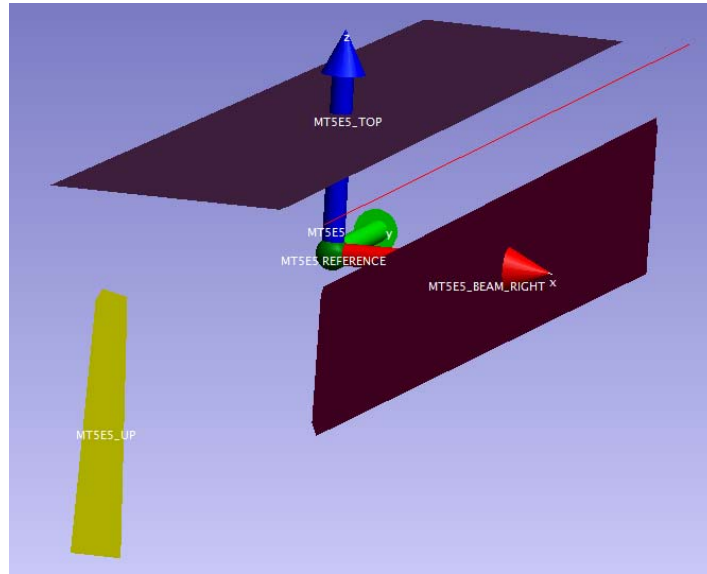

FRD 10532
HORZ. = 8.00"
VERT. = 6.25"
STA = 60.00



MT5E5 DOWNSTREAM (LOOKING UPSTREAM)



MT5Q1 UPSTREAM (LOOKING DOWNSTREAM)

MT5E5 REFERENCE VALUES						
Point Name	X	Y	Z	X	Y	Z
	[Inches]	[Inches]	[Inches]	[Metres]	[Metres]	[Metres]
MT5E5_UP	0.000	-60.000	0.000	0.00000	-1.52400	0.00000
MT5E5_CT	0.000	0.000	0.000	0.00000	0.00000	0.00000
MT5E5_DN	0.000	60.000	0.000	0.00000	1.52400	0.00000
MT5E5_TOP	0.000	0.000	6.250	0.00000	0.00000	0.15875
MT5E5_BEAM_RIGHT	8.000	0.000	0.000	0.20320	0.00000	0.00000

As-sets are shown relative to the Ideal Beam Sheet Position (Site coordinates for beam line: MTEST_r8.ces)

MT5E5 ACTUALS AS-SET LOCAL						
Point Name	X	Y	Z	X	Y	Z
	[Inches]	[Inches]	[Inches]	[Metres]	[Metres]	[Metres]
MT5E5_UP	-0.002	-0.007	-0.003	-0.00005	-0.00018	-0.00008
MT5E5_CT	-0.003	59.993	0.001	-0.00008	1.52383	0.00003
MT5E5_DN	-0.004	119.993	0.005	-0.00010	3.04783	0.00013
	ROLL(mrad)	PITCH(mrad)	YAW(mrad)			
	0.18	0.07	-0.02			

MT5E5 ACTUALS AS-SET FSCS(Z)			
Point Name	X	Y	Z
	[Metres]	[Metres]	[Metres]
MT5E5_UP	30263.162459	32127.541596	227.377831
MT5E5_CT	30262.844854	32129.032138	227.381815
MT5E5_DN	30262.527251	32130.522671	227.385799
	ROLL(mrad)	PITCH(mrad)	YAW(mrad)
	0.18	0.07	-0.02

NOTES: Coordinates for the device are in the FSCS(z) coordinate system.

(+X - axis) is East, (+Y - axis) is North, (+Z - axis) is Vertical elevation

+ve Roll is cw rotation about the +Y-axis

+ve Pitch is the Vertical angle above the X-Y plane

+ve Yaw is the cw rotation about the +ve Z-axis

MT5Q1 FRD#11159

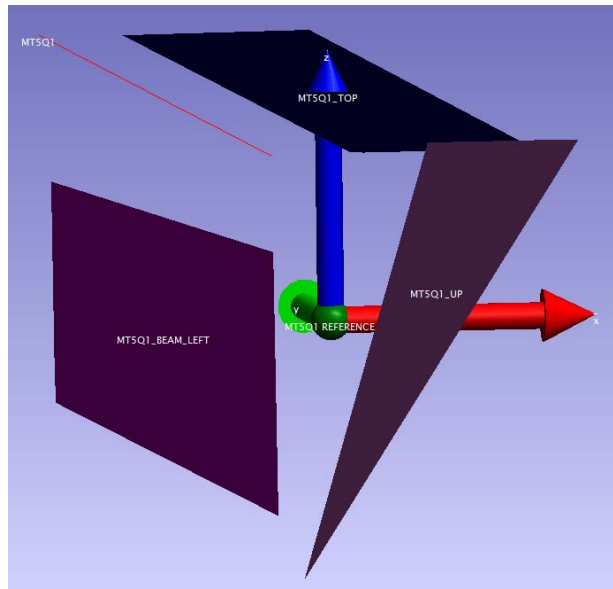

FRD 11159
VERT. = 8.5"
HORZ. = 6.5"
STA = 60"

MT5Q1 REFERENCE VALUES						
Point Name	X	Y	Z	X	Y	Z
	[Inches]	[Inches]	[Inches]	[Metres]	[Metres]	[Metres]
MT5Q1_UP	0.000	-60.000	0.000	0.00000	-1.52400	0.00000
MT5Q1_CT	0.000	0.000	0.000	0.00000	0.00000	0.00000
MT5Q1_DN	0.000	60.000	0.000	0.00000	1.52400	0.00000
MT5Q1_TOP	0.000	0.000	8.500	0.00000	0.00000	0.21590
MT5Q1_BEAM_LEFT	-6.500	0.000	0.000	-0.16510	0.00000	0.00000

As-sets are shown relative to the Ideal Beam Sheet Position (Site coordinates for beam line: MTEST_r8.ces)

MT5Q1 ACTUALS AS-SET LOCAL						
Point Name	X	Y	Z	X	Y	Z
	[Inches]	[Inches]	[Inches]	[Metres]	[Metres]	[Metres]
MT5Q1_UP	-0.009	0.372	-0.004	-0.00023	0.00945	-0.00010
MT5Q1_CT	-0.001	60.372	0.002	-0.00003	1.53345	0.00005
MT5Q1_DN	0.007	120.372	0.008	0.00018	3.05745	0.00020
	ROLL(mrad)	PITCH(mrad)	YAW(mrad)			
	1.43	0.10	0.13			

MT5Q1 ACTUALS AS-SET FSCS(Z)			
Point Name	X	Y	Z
	[Metres]	[Metres]	[Metres]
MT5Q1_UP	30260.816060	32138.732839	227.406868
MT5Q1_CT	30260.505325	32140.224826	227.410897
MT5Q1_DN	30260.194592	32141.716806	227.414925
	ROLL(mrad)	PITCH(mrad)	YAW(mrad)
	1.43	0.10	0.13

NOTES: Coordinates for the device are in the FSCS(z) coordinate system.

(+X - axis) is East, (+Y - axis) is North, (+Z - axis) is Vertical elevation

+ve Roll is cw rotation about the +Y-axis

+ve Pitch is the Vertical angle above the X-Y plane

+ve Yaw is the cw rotation about the +ve Z-axis

MT5Q2 FRD#11669

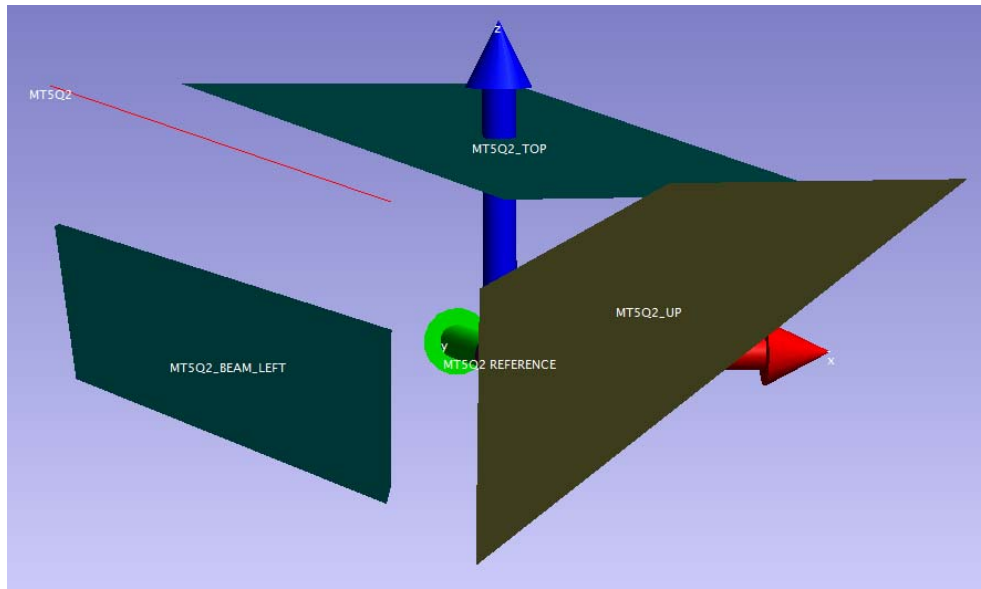

FRD 11669
VERT. = 6.5"
HORZ. = 8.5"
STA = 120

MT5Q2 REFERENCE VALUES						
Point Name	X	Y	Z	X	Y	Z
	[Inches]	[Inches]	[Inches]	[Metres]	[Metres]	[Metres]
MT5Q2_UP	0.000	-60.000	0.000	0.00000	-1.52400	0.00000
MT5Q2_CT	0.000	0.000	0.000	0.00000	0.00000	0.00000
MT5Q2_DN	0.000	60.000	0.000	0.00000	1.52400	0.00000
MT5Q2_TOP	0.000	0.000	6.500	0.00000	0.00000	0.16510
MT5Q2_BEAM_LEFT	-8.500	0.000	0.000	-0.21590	0.00000	0.00000

As-sets are shown relative to the Ideal Beam Sheet Position (Site coordinates for beam line: MTEST_r8.ces)

MT5Q2 ACTUALS AS-SET LOCAL						
Point Name	X	Y	Z	X	Y	Z
	[Inches]	[Inches]	[Inches]	[Metres]	[Metres]	[Metres]
MT5Q2_UP	0.002	-0.145	-0.006	0.00005	-0.00368	-0.00015
MT5Q2_CT	0.004	59.855	-0.002	0.00010	1.52032	-0.00005
MT5Q2_DN	0.007	119.855	0.003	0.00018	3.04432	0.00008
	ROLL(mrad)	PITCH(mrad)	YAW(mrad)			
	0.04	0.07	0.04			

MT5Q2 ACTUALS AS-SET FSCS(Z)			
Point Name	X	Y	Z
	[Metres]	[Metres]	[Metres]
MT5Q2_UP	30260.072778	32142.300690	227.416097
MT5Q2_CT	30259.761901	32143.792643	227.420072
MT5Q2_DN	30259.451025	32145.284593	227.424047
	ROLL(mrad)	PITCH(mrad)	YAW(mrad)
	0.04	0.07	0.04

NOTES: Coordinates for the device are in the FSCS(z) coordinate system.

(+X - axis) is East, (+Y - axis) is North, (+Z - axis) is Vertical elevation

+ve Roll is cw rotation about the +Y-axis

+ve Pitch is the Vertical angle above the X-Y plane

+ve Yaw is the cw rotation about the +ve Z-axis

MT5VT2 FRD#10921

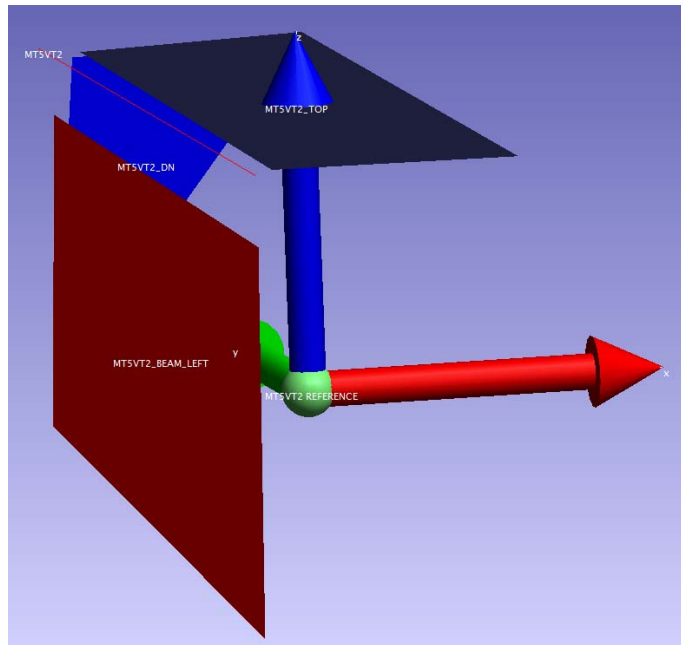

FRD # 10921
30" TRIM
16"H, 8.375"W, 30"L

MT5VT2 REFERENCE VALUES						
Point Name	X	Y	Z	X	Y	Z
	[Inches]	[Inches]	[Inches]	[Metres]	[Metres]	[Metres]
MT5VT2_UP	0.000	-15.000	0.000	0.00000	-0.38100	0.00000
MT5VT2_CT	0.000	0.000	0.000	0.00000	0.00000	0.00000
MT5VT2_DN	-0.000	15.000	0.000	0.00000	0.38100	0.00000
MT5VT2_TOP	0.000	0.000	8.000	0.00000	0.00000	0.20320
MT5VT2_BEAM_LEFT	-4.187	0.000	0.000	-0.10635	0.00000	0.00000

As-sets are shown relative to the Ideal Beam Sheet Position (Site coordinates for beam line: MTEST_r8.ces)

MT5VT2 ACTUALS AS-SET LOCAL						
Point Name	X	Y	Z	X	Y	Z
	[Inches]	[Inches]	[Inches]	[Metres]	[Metres]	[Metres]
MT5VT2_UP	-0.009	-0.100	0.009	-0.00023	-0.00254	0.00023
MT5VT2_CT	-0.048	14.899	0.002	-0.00122	0.37844	0.00005
MT5VT2_DN	-0.087	29.899	-0.004	-0.00221	0.75944	-0.00010
	ROLL(mrad)	PITCH(mrad)	YAW(mrad)			
	0.26	-0.45	-2.60			

MT5VT2 ACTUALS AS-SET FSCS (Z)			
Point Name	X	Y	Z
	[Metres]	[Metres]	[Metres]
MT5VT2_UP	30259.270331	32146.149696	227.426455
MT5VT2_CT	30259.191630	32146.522478	227.427254
MT5VT2_DN	30259.112928	32146.895260	227.428052
	ROLL(mrad)	PITCH(mrad)	YAW(mrad)
	0.26	-0.45	-2.60

NOTES: Coordinates for the device are in the FSCS(z) coordinate system.

(+X - axis) is East, (+Y - axis) is North, (+Z - axis) is Vertical elevation

+ve Roll is cw rotation about the +Y-axis

+ve Pitch is the Vertical angle above the X-Y plane

+ve Yaw is the cw rotation about the +ve Z-axis

NOTE: THESE NUMBERS ARE FROM 26-DEC-06 SURVEY. THIS MAGNET WAS NOT SURVEYED IN FEBURARY 2007 DUE TO TIME CONSTRAINTS.

MT5HT2 FRD#11613

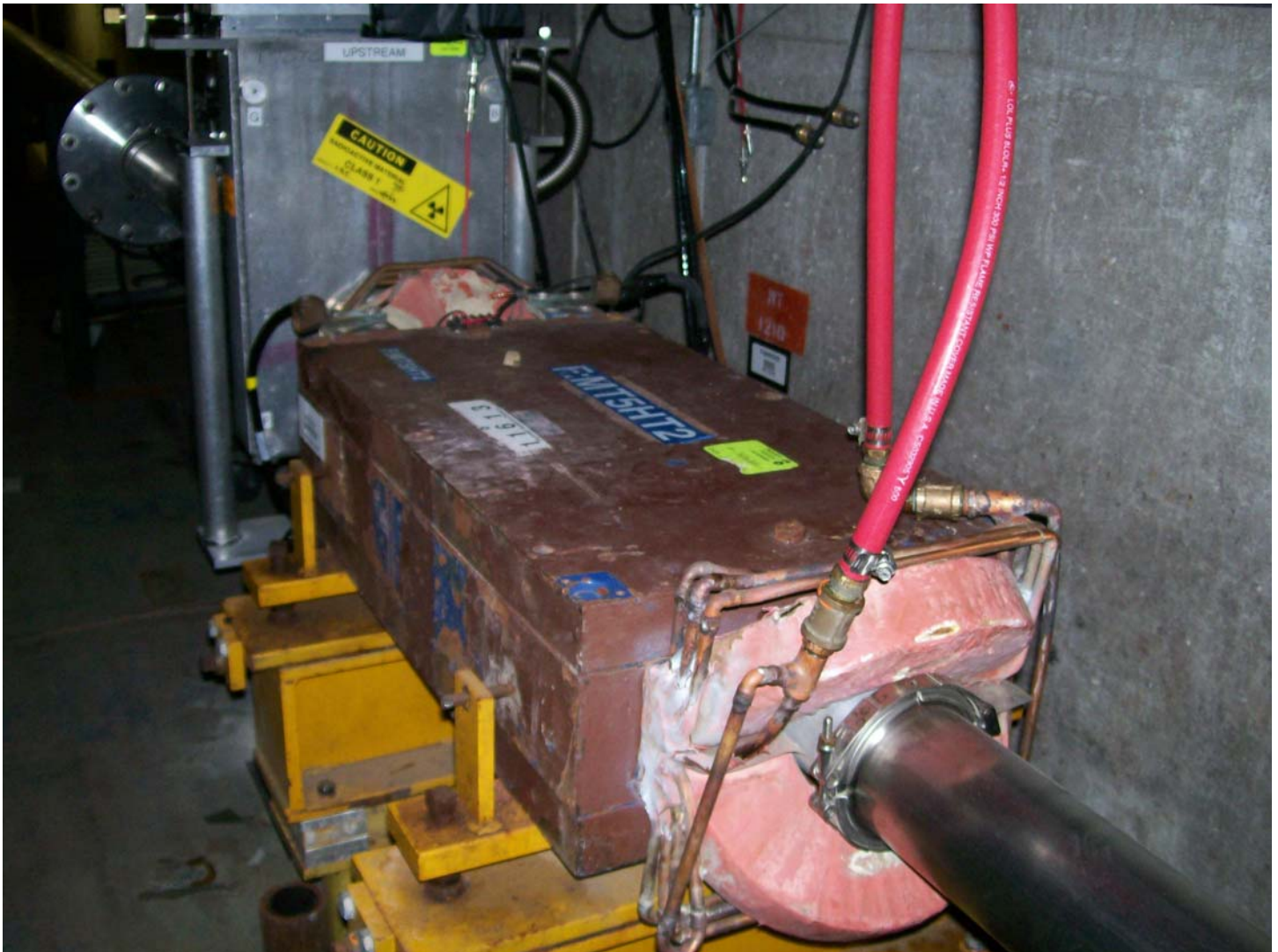
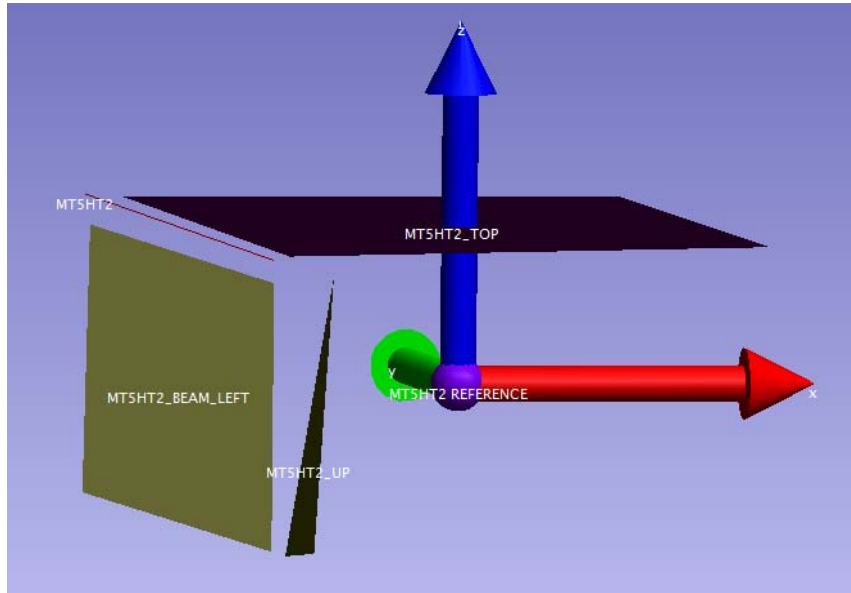

FRD # 11613
30" TRIM
16"W, 8.688"H, 30"L

MT5HT2 REFERENCE VALUES						
Point Name	X	Y	Z	X	Y	Z
	[Inches]	[Inches]	[Inches]	[Metres]	[Metres]	[Metres]
MT5HT2_UP	0.000	-15.000	0.000	0.00000	-0.38100	0.00000
MT5HT2_CT	0.000	0.000	0.000	0.00000	0.00000	0.00000
MT5HT2_DN	0.000	15.000	0.000	0.00000	0.38100	0.00000
MT5HT2_TOP	0.000	0.000	4.344	0.00000	0.00000	0.11034
MT5HT2_BEAM_LEFT	-8.000	0.000	0.000	-0.20320	0.00000	0.00000

As-sets are shown relative to the Ideal Beam Sheet Position (Site coordinates for beam line: MTEST_r8.ces)

MT5HT2 ACTUALS AS-SET LOCAL						
Point Name	X	Y	Z	X	Y	Z
	[Inches]	[Inches]	[Inches]	[Metres]	[Metres]	[Metres]
MT5HT2_UP	0.114	-0.152	-0.010	0.00290	-0.00386	-0.00025
MT5HT2_CT	0.101	14.848	-0.005	0.00257	0.37714	-0.00013
MT5HT2_DN	0.088	29.848	-0.000	0.00224	0.75814	0.00000
	ROLL(mrad)	PITCH(mrad)	YAW(mrad)			
	1.10	0.33	-0.88			

MT5HT2 ACTUALS AS-SET FSCS(Z)			
Point Name	X	Y	Z
	[Metres]	[Metres]	[Metres]
MT5HT2_UP	30258.737487	32147.765474	227.430167
MT5HT2_CT	30258.858732	32148.138391	227.431256
MT5HT2_DN	30258.780675	32148.511308	227.432345
	ROLL(mrad)	PITCH(mrad)	YAW(mrad)
	1.10	0.33	-0.88

NOTES: Coordinates for the device are in the FSCS(z) coordinate system.
 (+X - axis) is East, (+Y - axis) is North, (+Z - axis) is Vertical elevation

- +ve Roll is cw rotation about the +Y-axis
- +ve Pitch is the Vertical angle above the X-Y plane
- +ve Yaw is the cw rotation about the +ve Z-axis

NOTE: THESE NUMBERS ARE FROM 26-DEC-06 SURVEY. THIS MAGNET WAS NOT SURVEYED IN FEBURARY 2007 DUE TO TIME CONSTRAINTS.

MT5FP2 [FPM60077] REFERENCE



UPSTREAM VIEW



UPSTREAM VIEW

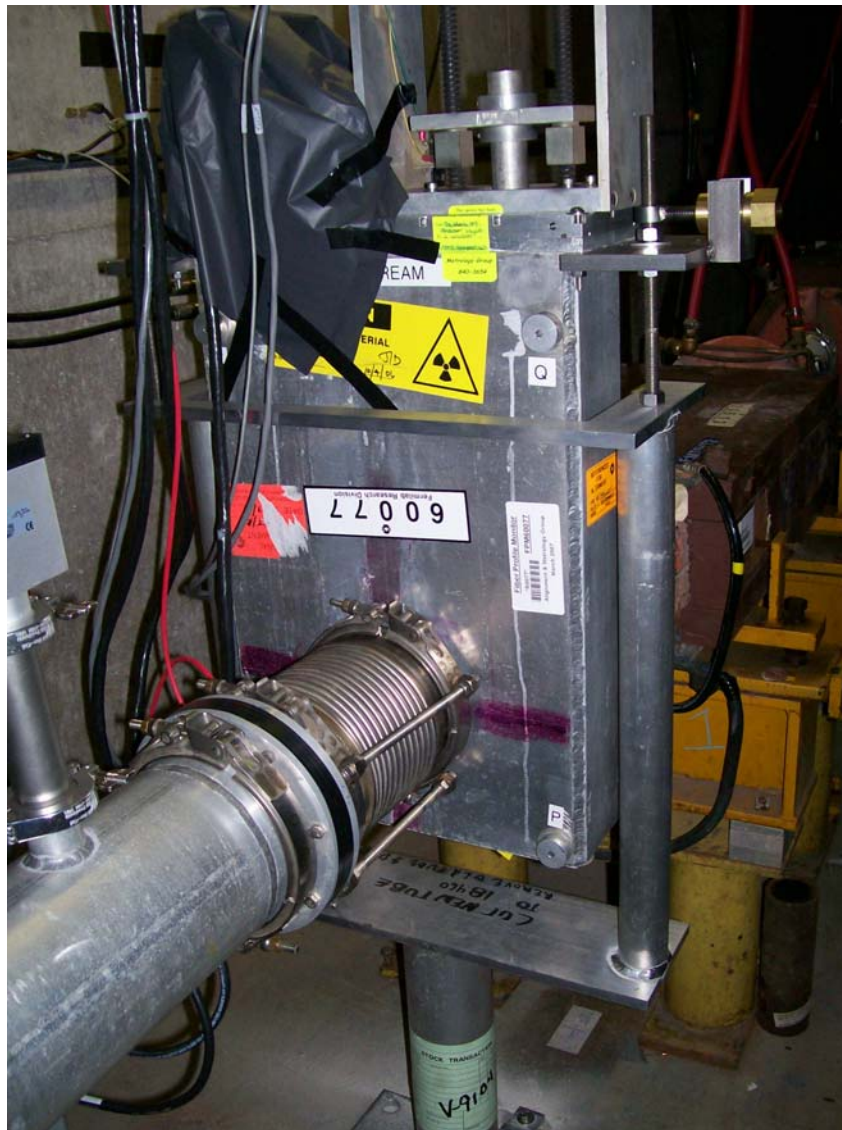

DOWNSTREAM VIEW

Reference File located in: G:\projects\7013\fpm\60077

MT5FP2 [60077] REFERENCE VALUES						
Point Name	X	Y	Z	X	Y	Z
	[Inches]	[Inches]	[Inches]	[Metres]	[Metres]	[Metres]
60077_B	6.736	-4.933	13.853	0.171	-0.125	0.352
60077_C	6.620	-4.940	-5.378	0.168	-0.125	-0.137
60077_F	-6.844	-4.940	-5.279	-0.174	-0.125	-0.134
60077_G	-6.752	-4.947	14.105	-0.172	-0.126	0.358
60077_K	6.776	2.695	14.093	0.172	0.068	0.358
60077_L	6.589	2.703	-5.313	0.167	0.069	-0.135
60077_P	-6.800	2.699	-5.274	-0.173	0.069	-0.134
60077_Q	-6.721	2.687	14.223	-0.171	0.068	0.361
60077_UP	0.000	-4.940	0.000	0.000	-0.125	0.000
60077_CT	0.000	0.000	0.000	0.000	0.000	0.000
60077_DN	0.000	2.701	0.000	0.000	0.069	0.000

This component was NOT surveyed in place. Reference values only.

MT5CV1

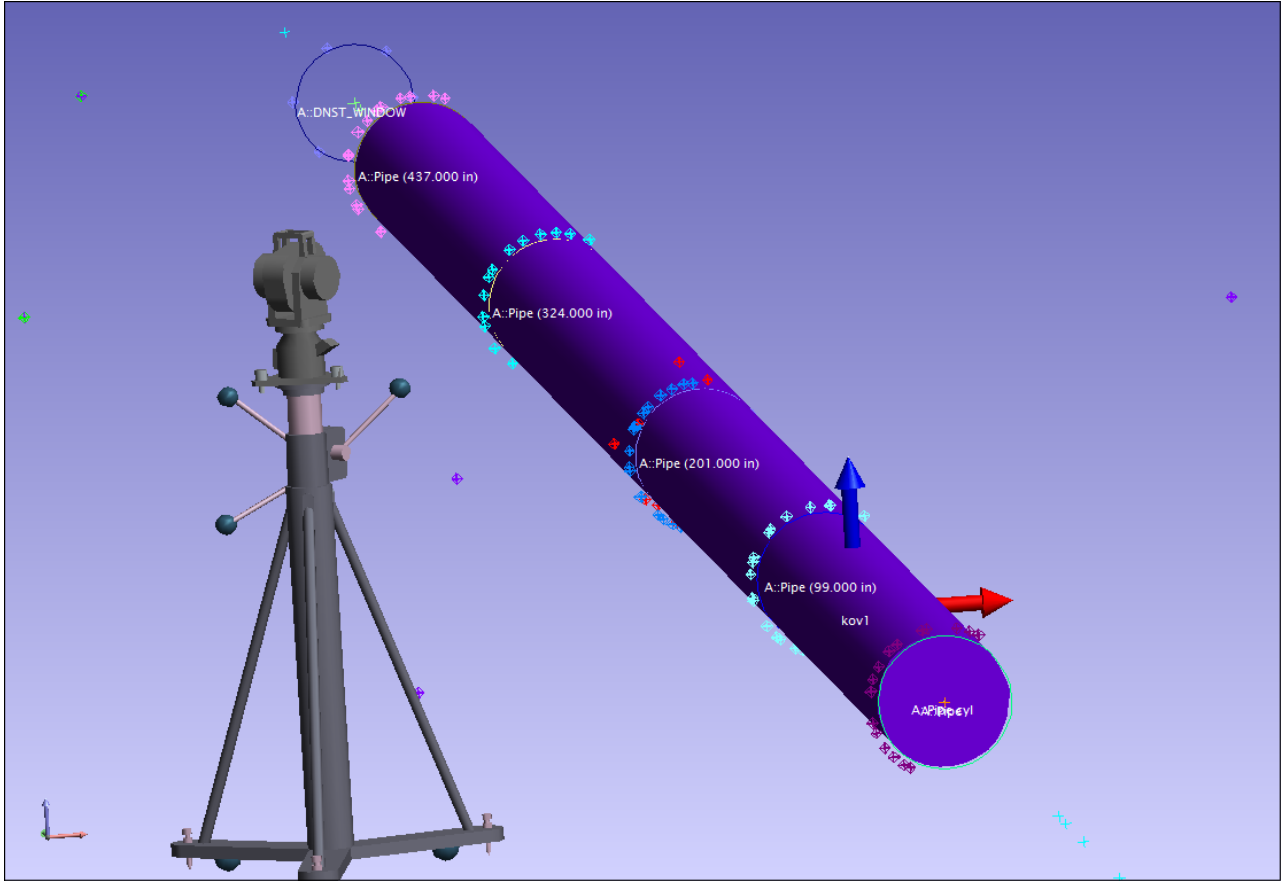

Rough Aligned 28-December-06



MT5CV1 UPSTREAM END



MT5CV1 UPSTREAM END



MT5CV1 UPSTREAM END (Looking Downstream)



MT5CV1 DOWNSTREAM END



MT5CV1 DOWNSTREAM END (Looking Upstream)

As-sets are shown relative to the Ideal Beam Sheet Position (Site coordinates for beam line: MTEST_r8.ces)

MT5CV1 ACTUALS AS-SET LOCAL						
Point Name	X	Y	Z	X	Y	Z
	[Inches]	[Inches]	[Inches]	[Metres]	[Metres]	[Metres]
MT5CV1_0	0.047	-72.750	-0.223	0.00119	-1.84785	-0.00566
MT5CV1_99	-0.025	27.750	-0.012	-0.00064	0.70485	-0.00030
MT5CV1_201	-0.044	129.750	0.036	-0.00112	3.29566	0.00091
MT5CV1_324	-0.103	252.750	0.204	-0.00262	6.41986	0.00518
MT5CV1_437	-0.054	365.750	0.188	-0.00137	9.29007	0.00478
MT5CV1_DN_WINDOW	-0.287	419.450	0.231	-0.00729	10.65405	0.00587
	ROLL(mrad)	PITCH(mrad)	YAW(mrad)			
		0.93	-0.23			

Pitch and Yaw reported with-respect-to MT5CV1_0 and MT5CV1_437.

MT5CV1 ACTUALS AS-SET FSCS(Z)			
Point Name	X	Y	Z
	[Metres]	[Metres]	[Metres]
MT5CV1_0	30258.171003	32151.431510	227.434260
MT5CV1_99	30257.648416	32153.930124	227.446108
MT5CV1_201	30257.119353	32156.466317	227.453923
MT5CV1_324	30256.480492	32159.524479	227.466119
MT5CV1_437	30255.896114	32162.334551	227.473005
MT5CV1_DN_WINDOW	30255.612040	32163.668627	227.477569
	ROLL(mrad)	PITCH(mrad)	YAW(mrad)
		0.93	-0.23

NOTES: Coordinates for the device are in the FSCS(z) coordinate system.

(+X - axis) is East, (+Y - axis) is North, (+Z - axis) is Vertical elevation

+ve Roll is cw rotation about the +Y-axis

+ve Pitch is the Vertical angle above the X-Y plane

+ve Yaw is the cw rotation about the +ve Z-axis

MT5CV2

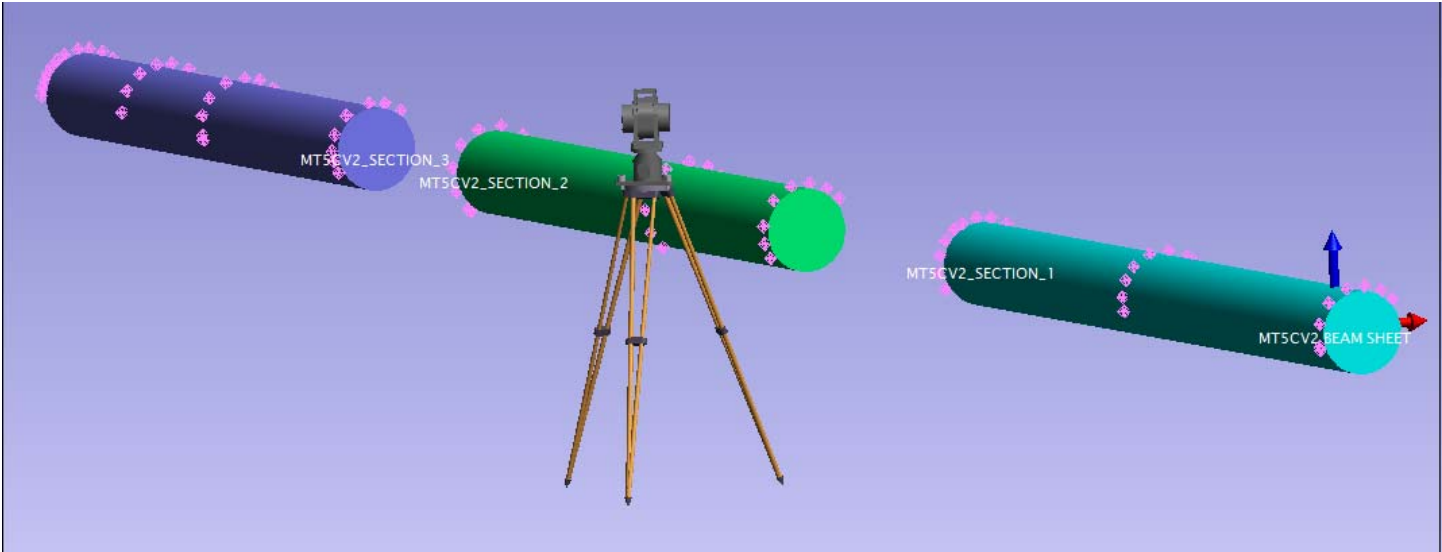
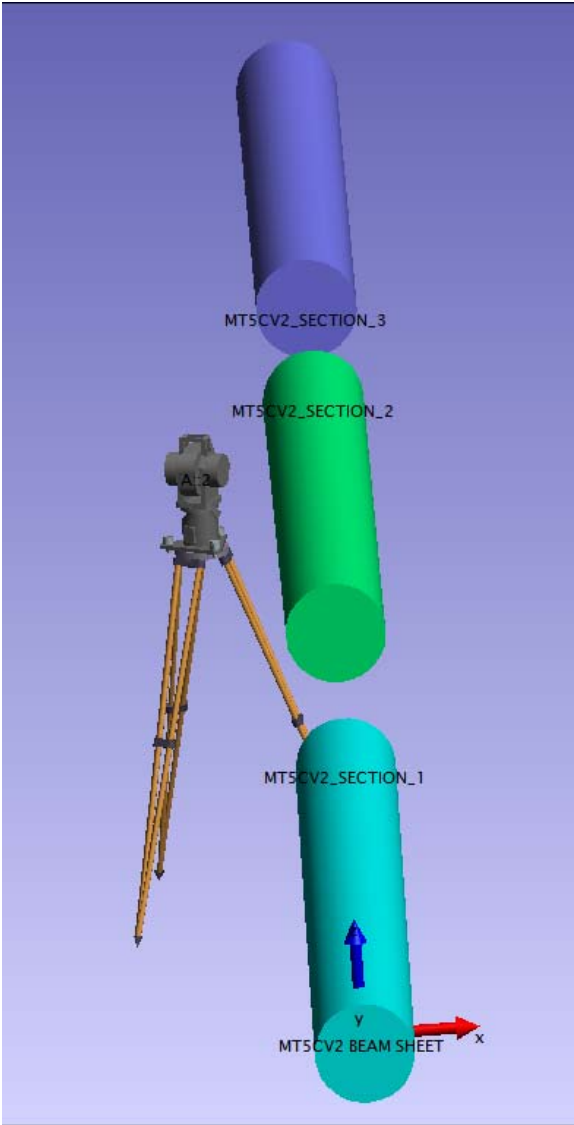



MT5CV2 UPSTREAM (Looking Downstream)



MT5CV2 UPSTREAM FLANGE



MT5CV2 UPSTREAM (Looking Downstream)



MT5CV2 (Looking Downstream)



MT5CV2 DOWNSTREAM (Looking Upstream)



MT5CV2 MIDSTREAM (Looking Upstream)



MT5CV2 DOWNSTREAM



MT5CV2 DOWNSTREAM FLANGE

As-sets are shown relative to the Ideal Beam Sheet Position (Site coordinates for beam line: MTEST_r8.ces)

MT5CV2 ACTUALS AS-SET LOCAL						
Point Name	X	Y	Z	X	Y	Z
	[Inches]	[Inches]	[Inches]	[Metres]	[Metres]	[Metres]
MT5CV2_0	0.212	-10.038	-0.061	0.00538	-0.25497	-0.00155
MT5CV2_157	0.617	146.813	-0.395	0.01567	3.72906	-0.01003
MT5CV2_230	0.645	219.062	-0.304	0.01638	5.56419	-0.00772
MT5CV2_255	0.125	345.373	-0.124	0.00318	8.77249	-0.00315
MT5CV2_404	0.102	394.087	0.005	0.00259	10.00983	0.00013
MT5CV2_523	-0.222	512.877	0.130	-0.00564	13.02710	0.00330
MT5CV2_DN_WINDOW	0.377	547.453	0.537	0.00958	13.90533	0.01364
	ROLL(mrad)	PITCH(mrad)	YAW(mrad)			
		1.07	0.29			

Pitch and Yaw reported with-respect-to MT5CV2_0 and MT5CV2_DN_WINDOW.

MT5CV1 ACTUALS AS-SET FSCS(Z)			
Point Name	X	Y	Z
	[Metres]	[Metres]	[Metres]
MT5CV2_0	30254.873195	32167.275945	227.479497
MT5CV2_157	30254.070416	32171.178271	227.481147
MT5CV2_230	30253.696713	32172.974927	227.488126
MT5CV2_255	30253.029218	32176.113025	227.500837
MT5CV2_404	30252.776202	32177.324213	227.507273
MT5CV2_523	30252.152570	32180.276309	227.518101
MT5CV2_DN_WINDOW	30251.988279	32181.139146	227.530672
	ROLL(mrad)	PITCH(mrad)	YAW(mrad)
		1.07	0.29

NOTES: Coordinates for the device are in the FSCS(z) coordinate system.

(+X - axis) is East, (+Y - axis) is North, (+Z - axis) is Vertical elevation

+ve Roll is cw rotation about the +Y-axis

+ve Pitch is the Vertical angle above the X-Y plane

+ve Yaw is the cw rotation about the +ve Z-axis

MT6FP [5304863]

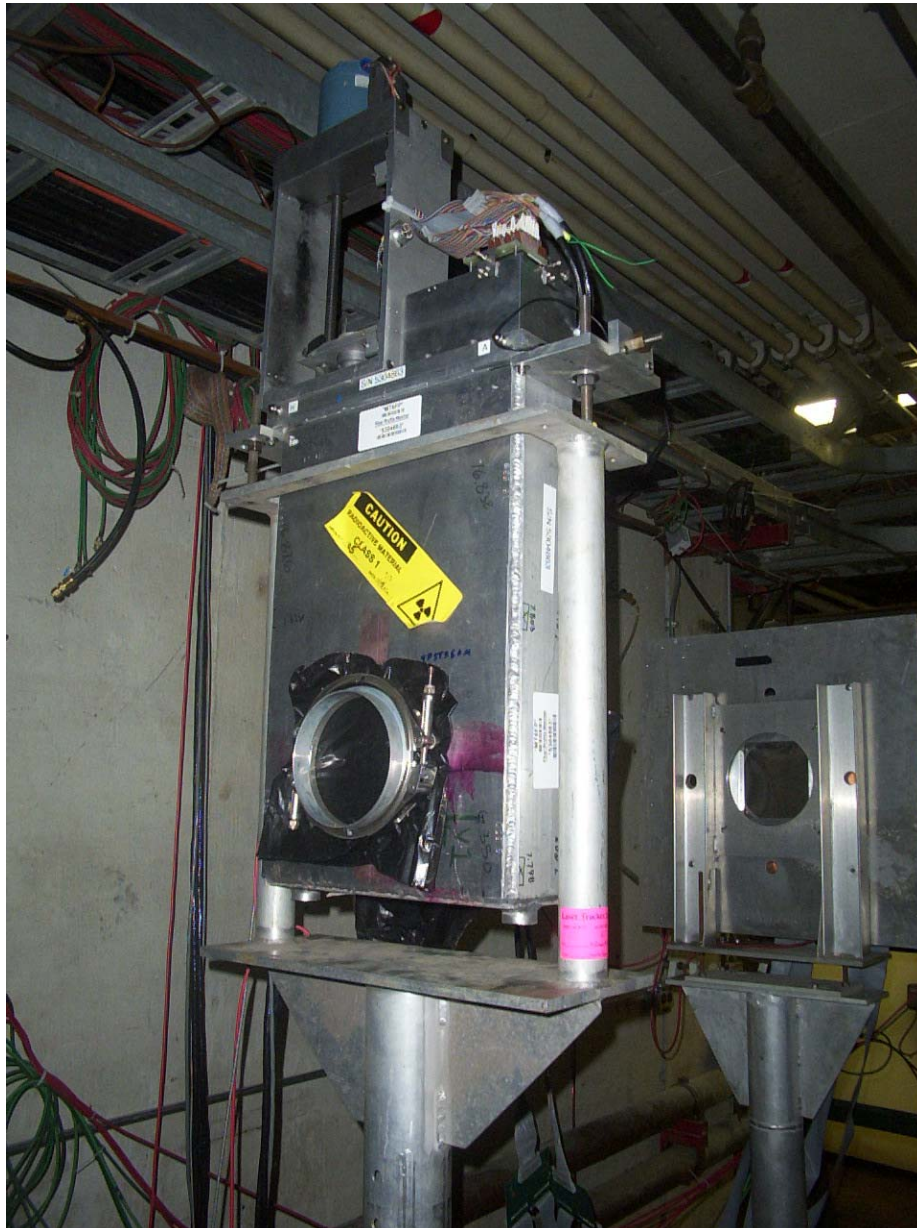
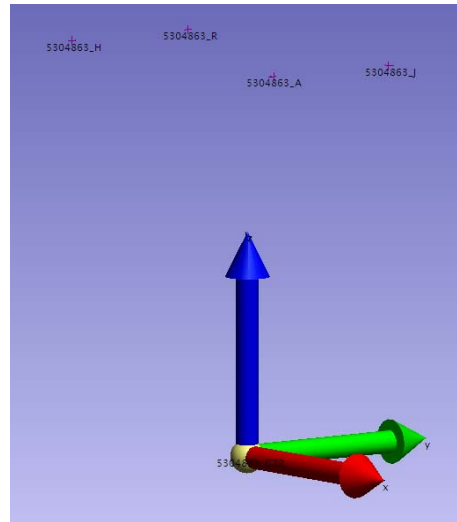

MT6FP Upstream (Looking Downstream)



MT6FP Upstream (Looking Downstream)



MT6FP Downstream (Looking Upstream)

Reference is based on optical tooling survey in calibration room.

MT6FPM_5304863_TB.xls

Reference File located in: G:\projects\7013\fpm\5304863

MT6FP [5304863] REFERENCE VALUES						
Point Name	X	Y	Z	X	Y	Z
	[Inches]	[Inches]	[Inches]	[Metres]	[Metres]	[Metres]
5304863_H	-7.351	-4.339	18.050	-0.18672	-0.11021	0.45847
5304863_A	7.273	-4.411	17.999	0.18473	-0.11204	0.45718
5304863_R	-7.323	2.157	18.048	-0.18600	0.05479	0.45842
5304863_J	7.306	2.088	17.997	0.18557	0.05304	0.45712
5304863_UP	0.000	-0.051	0.000	0.00000	-0.00130	0.00000
5304863_CT	0.000	0.000	0.000	0.00000	0.00000	0.00000
5304863_DN	0.000	0.051	0.000	0.00000	0.00130	0.00000

As-sets are shown relative to the Ideal Beam Sheet Position (Site coordinates for beam line: MTEST_r8.ces)

MT6FP [5304863] ACTUALS AS-SET LOCAL						
Point Name	X	Y	Z	X	Y	Z
	[Inches]	[Inches]	[Inches]	[Metres]	[Metres]	[Metres]
5304863_H	-7.282	-147.076	18.073	-0.18496	-3.73574	0.45906
5304863_A	7.343	-147.051	18.049	0.18651	-3.73510	0.45845
5304863_R	-7.297	-140.580	18.025	-0.18534	-3.57074	0.45784
5304863_J	7.333	-140.552	18.002	0.18626	-3.57003	0.45725
5304863_UP	0.075	-142.865	0.007	0.00191	-3.62878	0.00018
5304863_CT	0.075	-142.814	0.006	0.00191	-3.62748	0.00015
5304863_DN	0.074	-142.763	0.006	0.00188	-3.62619	0.00015

MT6FP [5304863] ACTUALS AS-SET FSCS (Z)			
Point Name	X	Y	Z
	[Metres]	[Metres]	[Metres]
5304863_H	30251.501984	32182.519199	227.979608
5304863_A	30251.865498	32182.595601	227.979013
5304863_R	30251.467947	32182.680648	227.978828
5304863_J	30251.831569	32182.757151	227.978233
5304863_UP	30251.662851	32182.663173	227.521009
5304863_CT	30251.662578	32182.664440	227.521003
5304863_DN	30251.662306	32182.665706	227.520997

NOTES: Coordinates for the device are in the FSCS(z) coordinate system.

(+X - axis) is East, (+Y - axis) is North, (+Z - axis) is Vertical elevation

+ve Roll is cw rotation about the +Y-axis

+ve Pitch is the Vertical angle above the X-Y plane

+ve Yaw is the cw rotation about the +ve Z-axis

MT6PWC1 REFERENCE

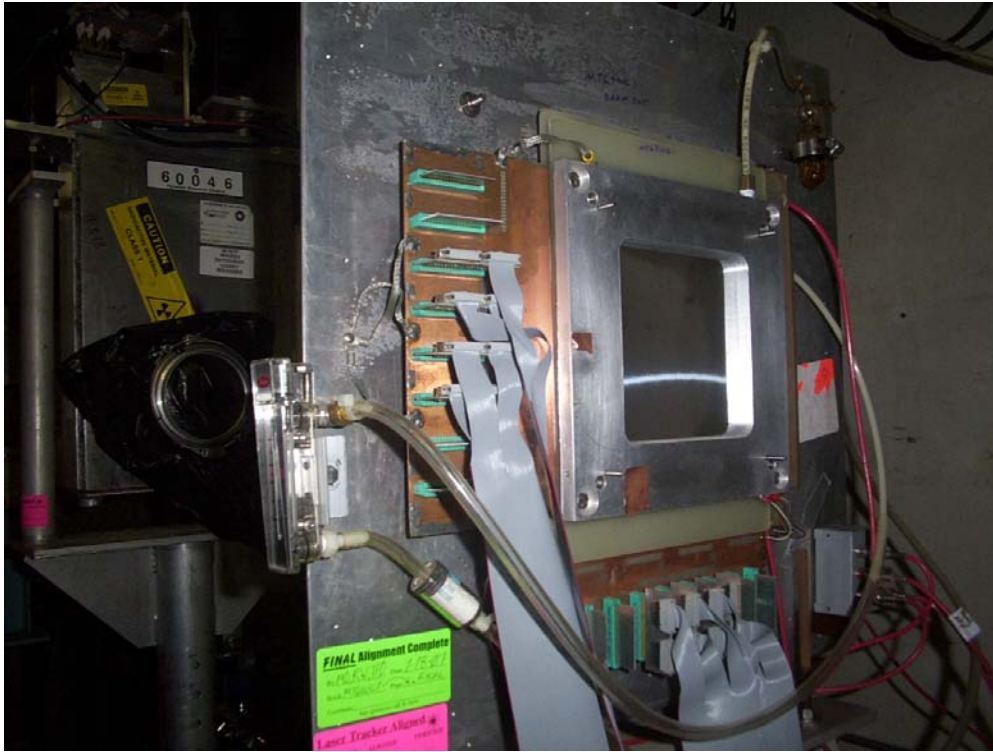

MT6PWC1 [MT6WC1] DOWNSTREAM



MT6PWC1 [MT6WC1] DOWNSTREAM



MT6FP / MT6PWC1 / TOF1

Reference is based on Best-fit Transformation to nominal pin values.

MT6PWC1 REFERENCE VALUES						
Point Name	X	Y	Z	X	Y	Z
	[Inches]	[Inches]	[Inches]	[Metres]	[Metres]	[Metres]
MT6PWC1_BOTTOM_BEAM_RIGHT_PIN	3.755	-0.005	-3.742			
MT6PWC1_TOP_BEAM_RIGHT_PIN	3.750	0.005	3.740			
MT6PWC1_TOP_BEAM_LEFT_PIN	-3.752	-0.005	3.742			
MT6PWC1_BOTTOM_BEAM_LEFT_PIN	-3.753	0.005	-3.740			
MT6PWC1_CT_PIN	-0.000	0.000	0.000			
MT6PWC1_TOP_BEAM_LEFT_INTER	-4.989	0.768	4.996			
MT6PWC1_BOTTOM_BEAM_LEFT_INTER	-5.011	0.759	-5.005			
MT6PWC1_BOTTOM_BEAM_RIGHT_INTER	4.956	0.754	-5.009			
MT6PWC1_TOP_BEAM_RIGHT_INTER	4.949	0.773	4.997			

As-sets are shown relative to the Ideal Beam Sheet Position (Site coordinates for beam line: MTEST_r8.ces)

MT6PWC1 ACTUALS AS-SET LOCAL						
Point Name	X	Y	Z	X	Y	Z
	[Inches]	[Inches]	[Inches]	[Metres]	[Metres]	[Metres]
MT6PWC1_BOTTOM_BEAM_RIGHT_PIN	-3.832	-117.129	3.764			
MT6PWC1_TOP_BEAM_RIGHT_PIN	-3.814	-117.285	-3.735			
MT6PWC1_TOP_BEAM_LEFT_PIN	3.683	-117.496	-3.712			
MT6PWC1_BOTTOM_BEAM_LEFT_PIN	3.665	-117.341	3.786			
MT6PWC1_CT_PIN	-0.075	-117.313	0.026			

MT6PWC1 ACTUALS AS-SET FSCS(Z)			
Point Name	X	Y	Z
	[Metres]	[Metres]	[Metres]
MT6PWC1_BOTTOM_BEAM_RIGHT_PIN	30251.337768	32183.736420	227.619430
MT6PWC1_TOP_BEAM_RIGHT_PIN	30251.338923	32183.733114	227.428962
MT6PWC1_TOP_BEAM_LEFT_PIN	30251.526436	32183.766716	227.429516
MT6PWC1_BOTTOM_BEAM_LEFT_PIN	30251.525281	32183.770022	227.619984
MT6PWC1_CT_PIN	30251.432102	32183.751568	227.524473
	ROLL(mrad)	PITCH(mrad)	YAW(mrad)

NOTES: Coordinates for the device are in the FSCS(z) coordinate system.

(+X - axis) is East, (+Y - axis) is North, (+Z - axis) is Vertical elevation

+ve Roll is cw rotation about the +Y-axis

+ve Pitch is the Vertical angle above the X-Y plane

+ve Yaw is the cw rotation about the +ve Z-axis

MT6 SECTION 1 TOF1

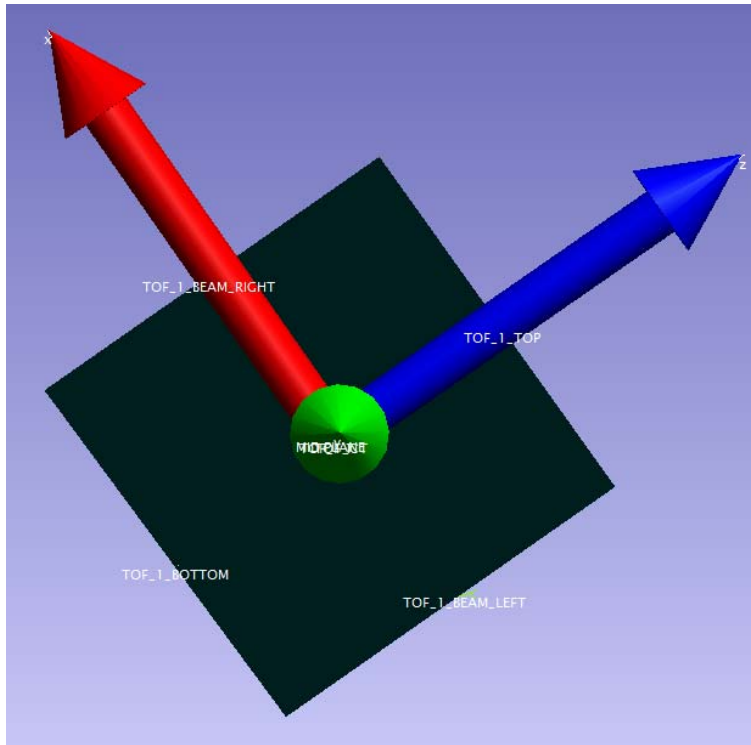

Coordinate System (Looking Upstream)

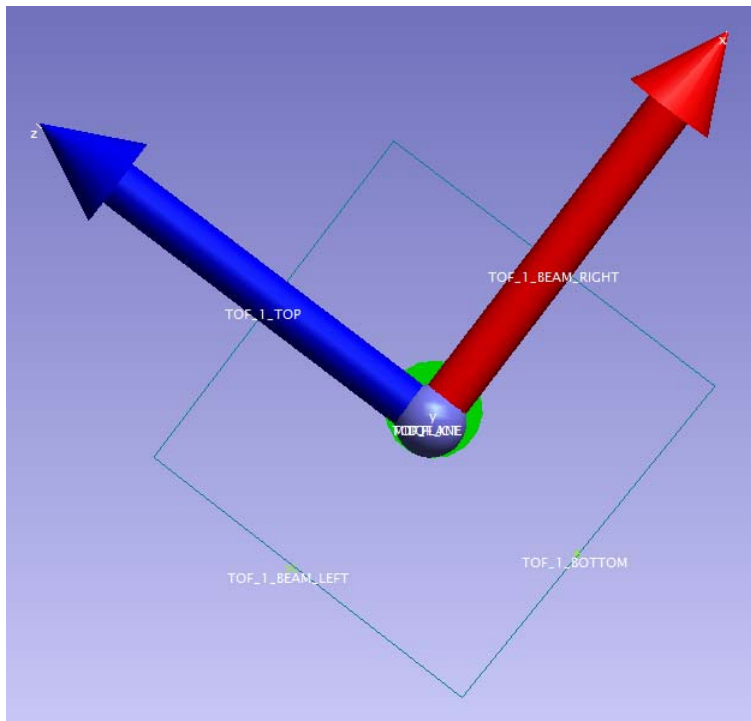

Coordinate System (Looking Downstream)

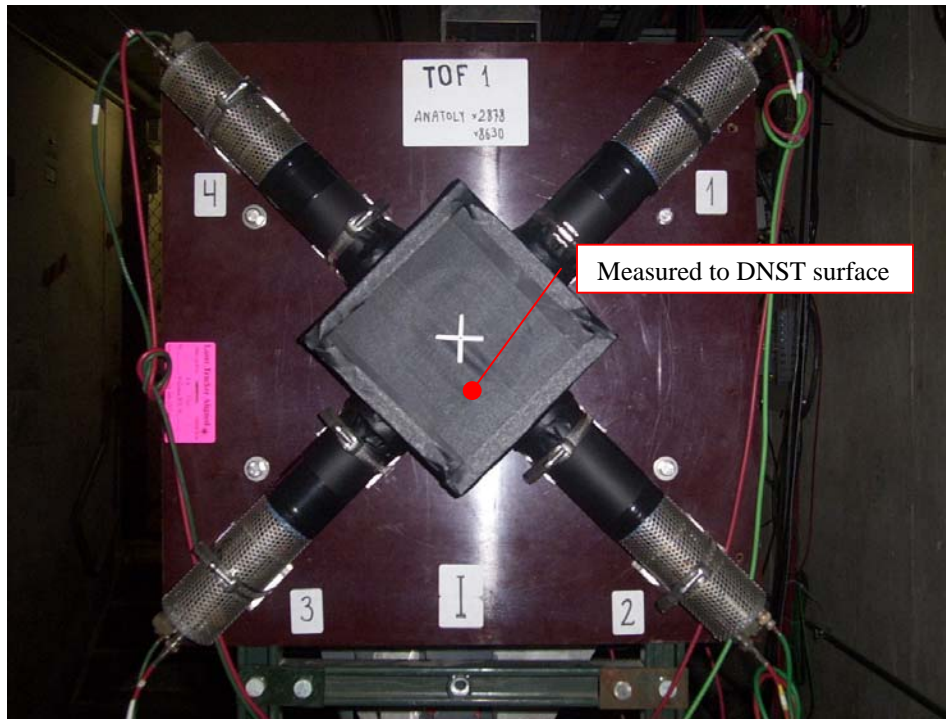

TOF1 DOWNSTREAM (Looking Upstream)

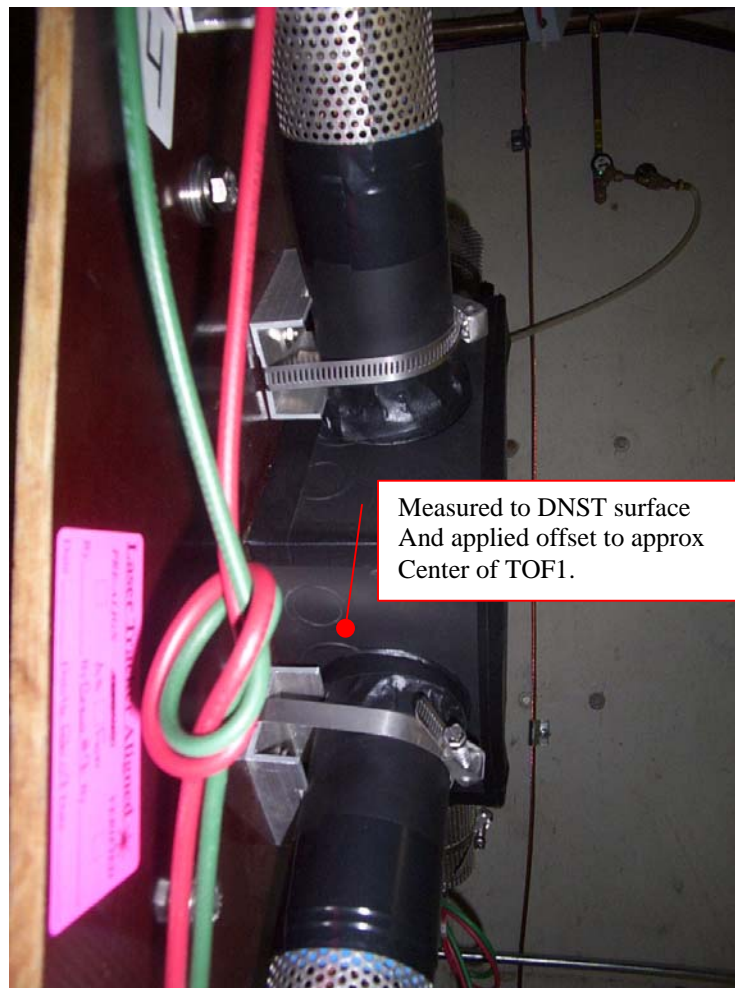

TOF1 (Looking from Beam Right)



TOF1 DOWNSTREAM (Looking Upstream)

Reference is based on sides of TOF1.

Origin: Centroid of Intersection of Lines (Translated Upstream 2")

[Top, Bottom, Beam right, Beam left]

Normal Vector of Downstream Plane

Vector passing thru Top of TOF

NOTE: REFERENCE COORDINATE SYSTEM IS ROTATED -45 DEGREES

MT6TOF1 REFERENCE VALUES						
Point Name	X	Y	Z	X	Y	Z
	[Inches]	[Inches]	[Inches]	[Metres]	[Metres]	[Metres]
MT6TOF1_CT	0.000	0.000	0.000	0.00000	0.00000	0.00000
MT6TOF1_TOP	-0.118	-0.010	4.059	-0.00300	-0.00025	0.10310
MT6TOF1_BEAM_LEFT	-4.076	-0.018	0.393	-0.10353	-0.00046	0.00998
MT6TOF1_BOTTOM	-0.299	0.012	-4.049	-0.00759	0.00030	-0.10284
MT6TOF1_BEAM_RIGHT	4.079	0.016	-0.181	0.10361	0.00041	-0.00460

As-sets are shown relative to the Ideal Beam Sheet Position (Site coordinates for beam line: MTEST_r8.ces)

MT6TOF1 ACTUALS AS-SET LOCAL						
Point Name	X	Y	Z	X	Y	Z
	[Inches]	[Inches]	[Inches]	[Metres]	[Metres]	[Metres]
MT6TOF1_CT	-0.125		-0.061			

MT6TOF1 ACTUALS AS-SET FSCS(Z)			
Point Name	X	Y	Z
	[Metres]	[Metres]	[Metres]
MT6TOF1_CT	30251.316069	32184.302120	227.523700

NOTES: Coordinates for the device are in the FSCS(z) coordinate system.

(+X - axis) is East, (+Y - axis) is North, (+Z - axis) is Vertical elevation

+ve Roll is cw rotation about the +Y-axis

+ve Pitch is the Vertical angle above the X-Y plane

+ve Yaw is the cw rotation about the +ve Z-axis

MT6 SECTION 1 MT6PWC2

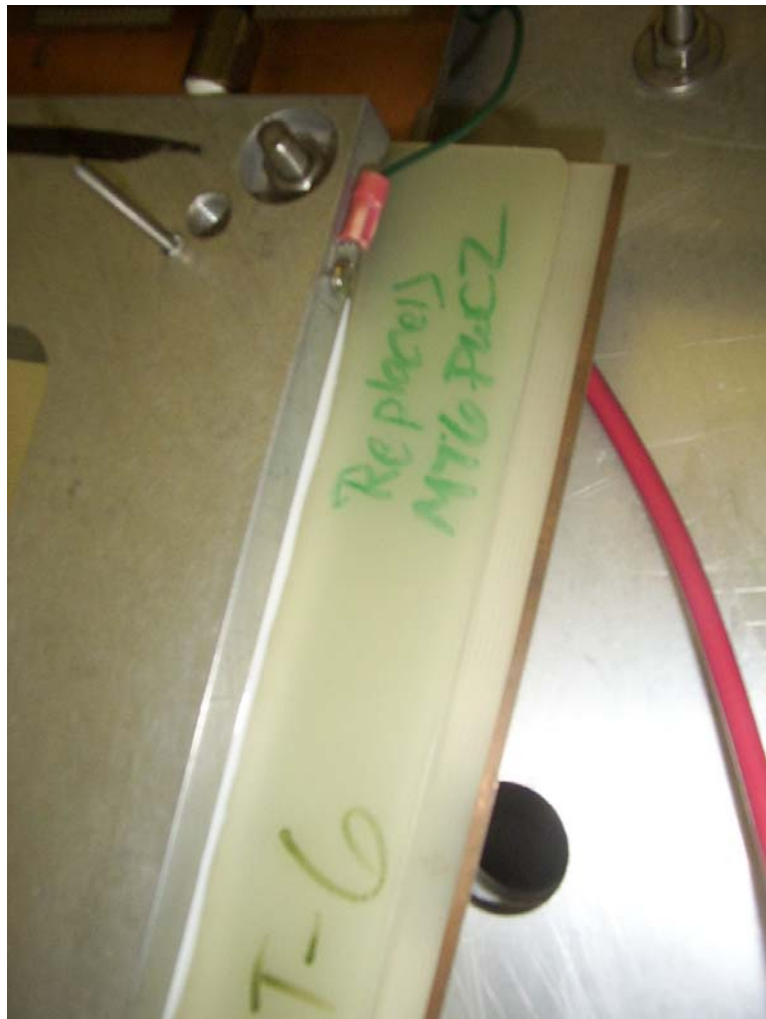
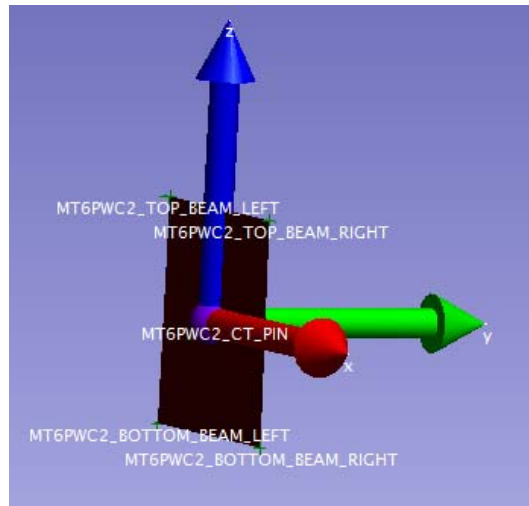

MT6 SECTION 1 MT6PWC2



MT6PWC2 DOWNSTREAM OF HUT

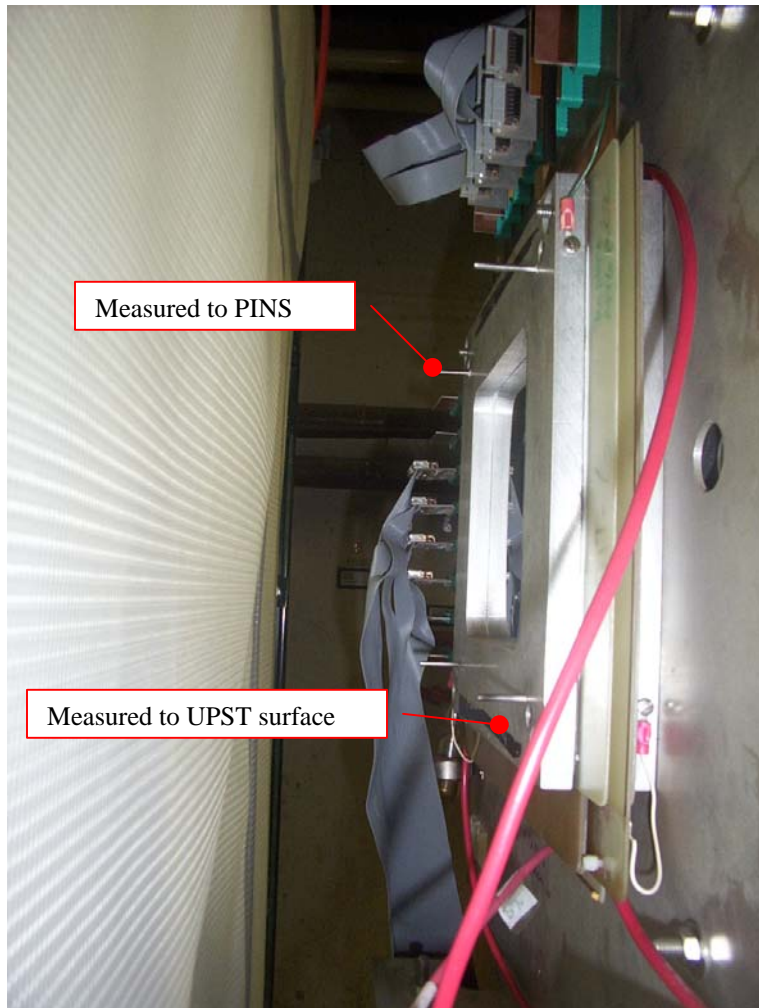

MT6PWC2 BEAM RIGHT VIEW

Reference is based on Best-fit Transformation to nominal pin values.

MT6PWC2 REFERENCE VALUES						
Point Name	X	Y	Z	X	Y	Z
	[Inches]	[Inches]	[Inches]	[Metres]	[Metres]	[Metres]
MT6PWC2_TOP_BEAM_LEFT_PIN	-3.751	-0.003	3.746	-0.09528	-0.00009	0.09515
MT6PWC2_TOP_BEAM_RIGHT_PIN	3.763	0.003	3.747	0.09558	0.00009	0.09516
MT6PWC2_BOTTOM_BEAM_RIGHT_PIN	3.750	-0.003	-3.744	0.09524	-0.00009	-0.09509
MT6PWC2_BOTTOM_BEAM_LEFT_PIN	-3.760	0.003	-3.749	-0.09552	0.00009	-0.09523
MT6PWC2_CT_PIN	0.000	0.000	0.000	0.00000	0.00000	0.00000

As-sets are shown relative to the Ideal Beam Sheet Position (Site coordinates for beam line: MTEST_r8.ces)

NOTE: THIS COMPONENT DOES NOT APPEAR ON THE BEAM SHEET – THEREFORE IGNORE THE Y VALUES FOR THE AS-SET LOCAL

MT6PWC2 ACTUALS AS-SET LOCAL						
Point Name	X	Y	Z	X	Y	Z
	[Inches]	[Inches]	[Inches]	[Metres]	[Metres]	[Metres]
MT6PWC2_TOP_BEAM_LEFT	-3.666	-0.042	3.778	-0.09311	-0.00106	0.09596
MT6PWC2_TOP_BEAM_RIGHT	3.834	-0.015	3.761	0.09738	-0.00037	0.09554
MT6PWC2_BOTTOM_BEAM_RIGHT	3.817	0.042	-3.738	0.09696	0.00106	-0.09495
MT6PWC2_BOTTOM_BEAM_LEFT	-3.683	0.015	-3.722	-0.09354	0.00037	-0.09454
MT6PWC2_CT_PIN	0.076	0.000	0.020	0.00192	0.00000	0.00050
	ROLL(mrad)	PITCH(mrad)	YAW(mrad)			
	2.18	7.49	-3.59			

MT6PWC2 ACTUALS AS-SET FSCS(Z)			
Point Name	X	Y	Z
	[Metres]	[Metres]	[Metres]
MT6PWC2_TOP_BEAM_LEFT	30249.331758	32193.382564	227.644827
MT6PWC2_TOP_BEAM_RIGHT	30249.518109	32193.422102	227.644412
MT6PWC2_BOTTOM_BEAM_RIGHT	30249.517307	32193.423884	227.453922
MT6PWC2_BOTTOM_BEAM_LEFT	30249.330956	32193.384345	227.454337
MT6PWC2_CT_PIN	30249.424532	32193.403224	227.549375
	ROLL(mrad)	PITCH(mrad)	YAW(mrad)
	2.18	7.49	-3.59

NOTES: Coordinates for the device are in the FSCS(z) coordinate system.

(+X - axis) is East, (+Y - axis) is North, (+Z – axis) is Vertical elevation

+ve Roll is cw rotation about the +Y-axis

+ve Pitch is the Vertical angle above the X-Y plane

+ve Yaw is the cw rotation about the +ve Z-axis

MT6 SECTION 2 PWC1A

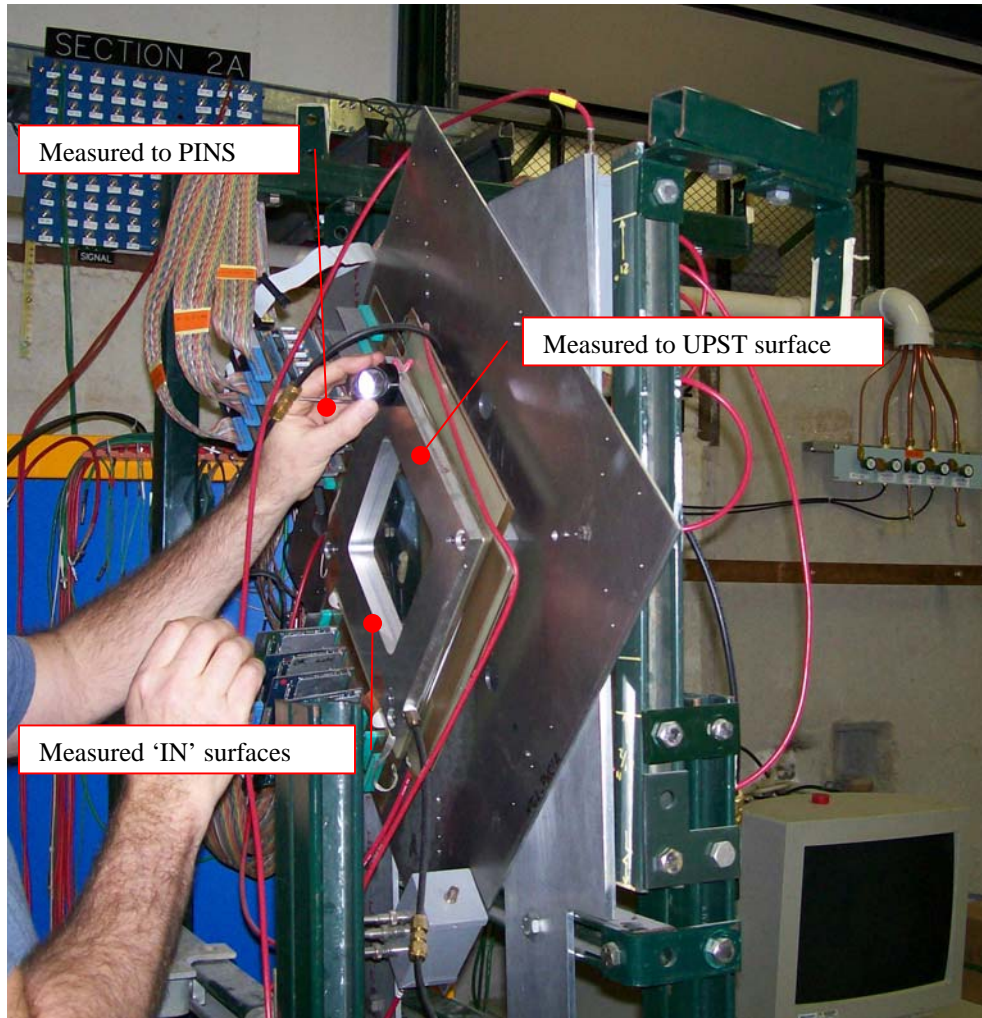
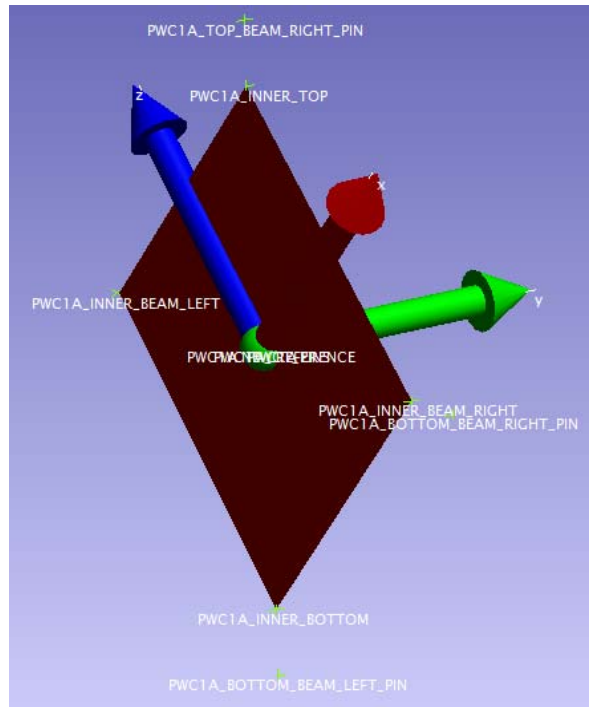

PWC1A UPSTREAM (Looking from Beam Right)

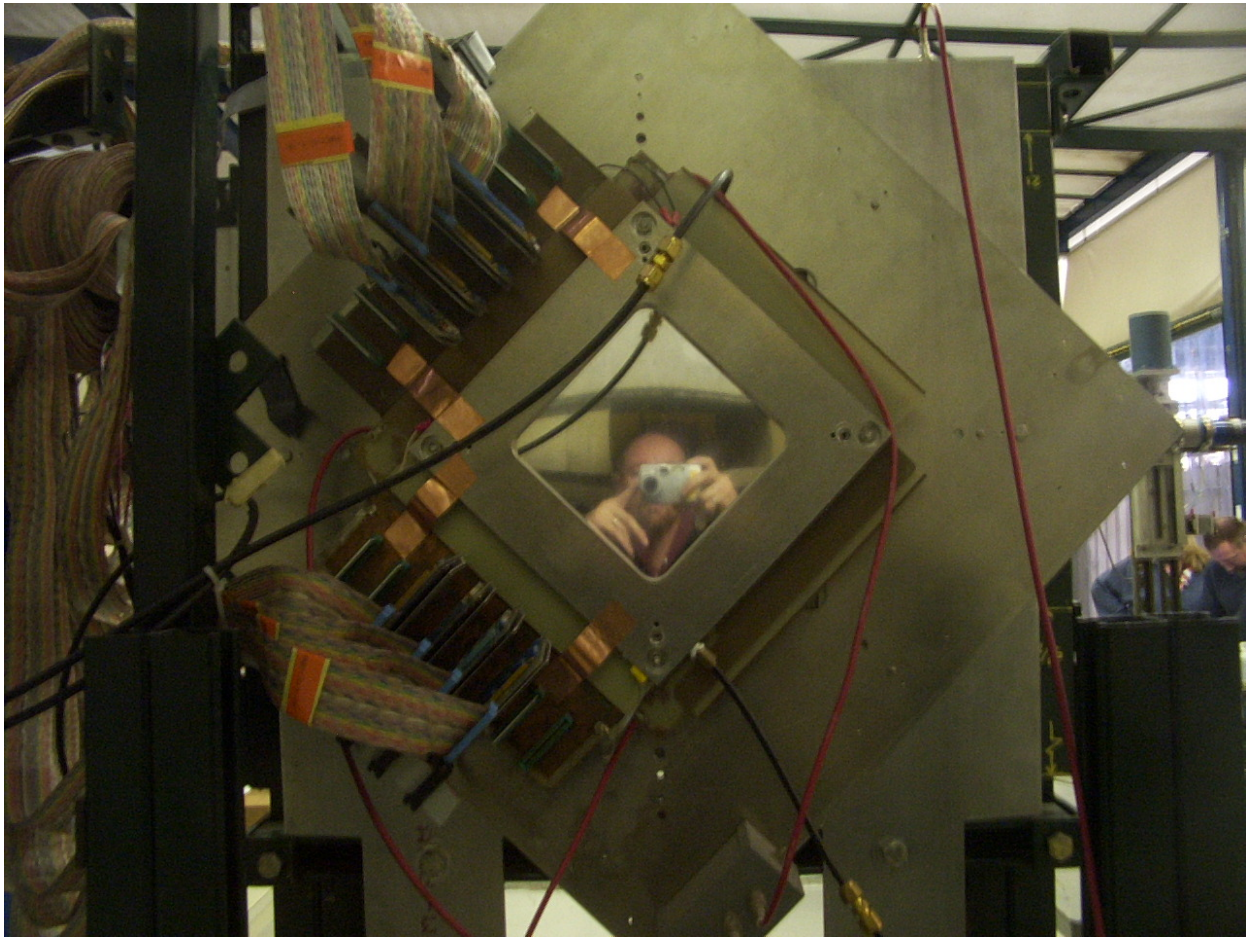

PWC1A UPSTREAM (Looking Downstream)

Reference is based on Best-fit Transformation to nominal pin values.

MT62_PWC1A REFERENCE VALUES						
Point Name	X	Y	Z	X	Y	Z
	[Inches]	[Inches]	[Inches]	[Metres]	[Metres]	[Metres]
MT62_PWC1A_INNER_TOP	3.005	-0.001	3.001	0.07633	-0.00002	0.07623
MT62_PWC1A_INNER_BOTTOM	-3.007	0.003	-3.004	-0.07638	0.00009	-0.07630
MT62_PWC1A_INNER_BEAM_RIGHT	3.006	0.000	-3.001	0.07636	0.00001	-0.07623
MT62_PWC1A_INNER_BEAM_LEFT	-3.006	-0.005	3.002	-0.07636	-0.00013	0.07625
MT62_PWC1A_BOTTOM_BEAM_RIGHT_PIN	3.754	0.000	-3.755	0.09535	0.00010	-0.09537
MT62_PWC1A_TOP_BEAM_RIGHT_PIN	3.755	0.000	3.755	0.09537	0.00010	0.09539
MT62_PWC1A_BOTTOM_BEAM_LEFT_PIN	-3.758	0.000	-3.757	-0.09547	0.00010	-0.09542
MT62_PWC1A_CT_PINS	-0.000	-0.000	-0.000	0.00000	0.00000	0.00000

As-sets are shown relative to the Ideal Beam Sheet Position (Site coordinates for beam line: MTEST_r8.ces)

NOTE: THIS COMPONENT DOES NOT APPEAR ON THE BEAM SHEET – THEREFORE IGNORE THE Y VALUES FOR THE AS-SET LOCAL

MT62_PWC1A ACTUALS AS-SET LOCAL						
Point Name	X	Y	Z	X	Y	Z
	[Inches]	[Inches]	[Inches]	[Metres]	[Metres]	[Metres]
MT62_PWC1A_INNER_TOP	-0.064	-0.087	4.080	-0.00161	-0.00230	0.10364
MT62_PWC1A_INNER_BOTTOM	-0.022	0.089	-4.415	-0.00056	0.00217	-0.11215
MT62_PWC1A_INNER_BEAM_RIGHT	4.205	-0.035	-0.139	0.10680	-0.00099	-0.00354
MT62_PWC1A_INNER_BEAM_LEFT	-4.292	0.030	-0.192	-0.10901	0.00067	-0.00487
MT62_PWC1A_BOTTOM_BEAM_RIGHT_PIN	5.266	-0.040	-0.138	0.13376	-0.00112	-0.00351
MT62_PWC1A_TOP_BEAM_RIGHT_PIN	-0.073	-0.103	5.144	-0.00185	-0.00273	0.13065
MT62_PWC1A_BOTTOM_BEAM_LEFT_PIN	-0.015	0.112	-5.479	-0.00038	0.00273	-0.13916
MT62_PWC1A_CT_PINS	-0.043	-0.000	-0.166	-0.00109	-0.00011	-0.00423

MT62_PWC1A ACTUALS AS-SET FSCS (Z)			
Point Name	X	Y	Z
	[Metres]	[Metres]	[Metres]
MT62_PWC1A_INNER_TOP	30248.176397	32199.374803	227.668010
MT62_PWC1A_INNER_BOTTOM	30248.176407	32199.379934	227.452235
MT62_PWC1A_INNER_BEAM_RIGHT	30248.282203	32199.398470	227.560832
MT62_PWC1A_INNER_BEAM_LEFT	30248.070601	32199.356075	227.559509
MT62_PWC1A_BOTTOM_BEAM_RIGHT_PIN	30248.308623	32199.403744	227.560863
MT62_PWC1A_TOP_BEAM_RIGHT_PIN	30248.176266	32199.374171	227.695016
MT62_PWC1A_BOTTOM_BEAM_LEFT_PIN	30248.176448	32199.380486	227.425226
MT62_PWC1A_CT_PINS	30248.176402	32199.377320	227.560147

NOTES: Coordinates for the device are in the FSCS(z) coordinate system.

(+X - axis) is East, (+Y - axis) is North, (+Z – axis) is Vertical elevation

+ve Roll is cw rotation about the +Y-axis

+ve Pitch is the Vertical angle above the X-Y plane

+ve Yaw is the cw rotation about the +ve Z-axis

MT6 SECTION 2 PWC1B

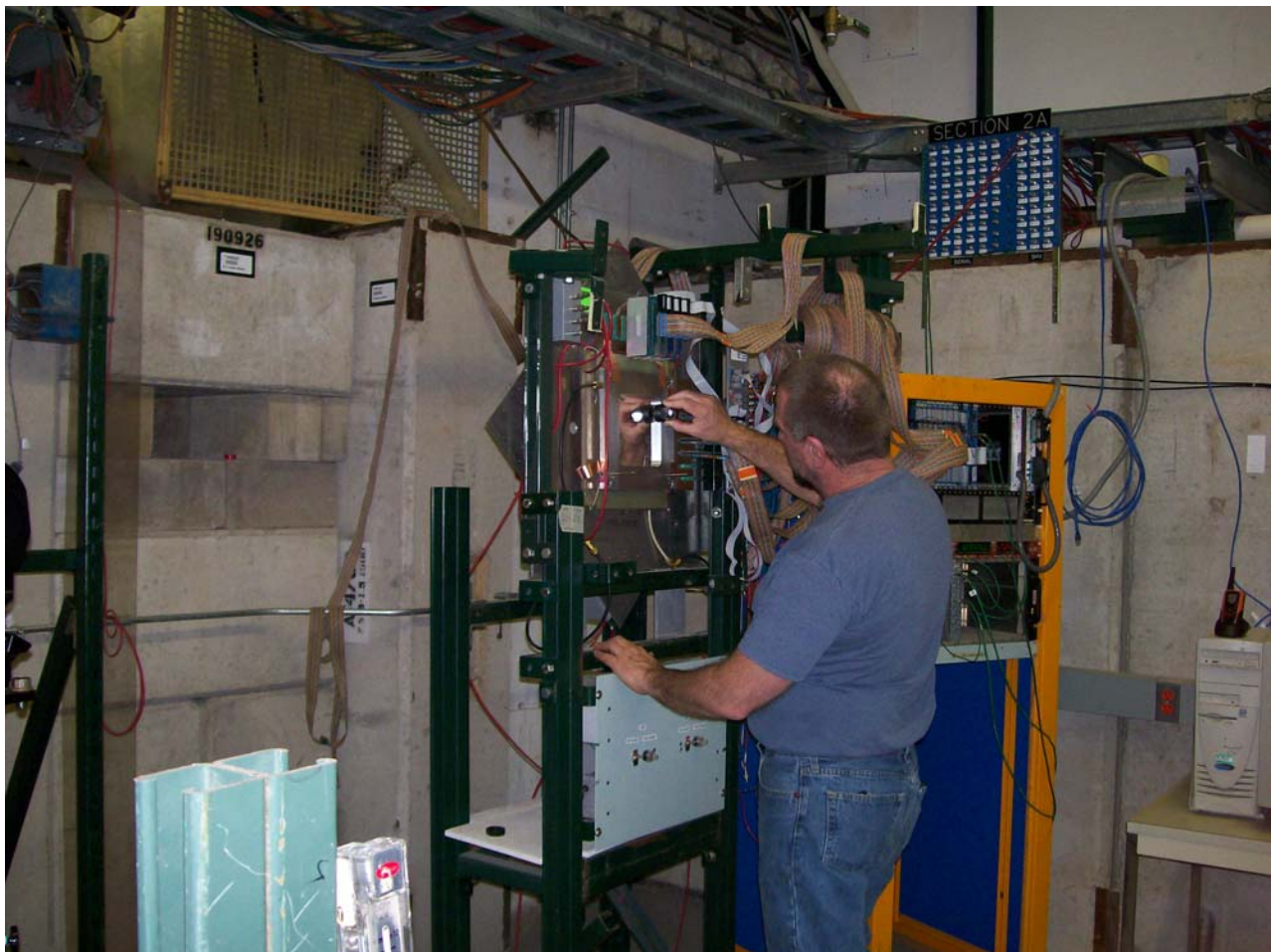
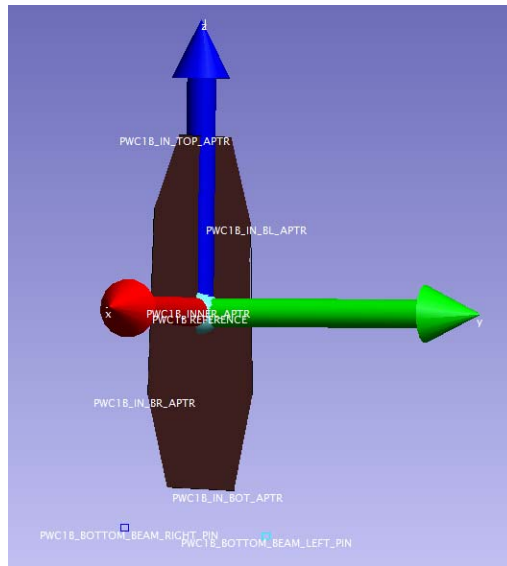

PWC1B DOWNSTREAM

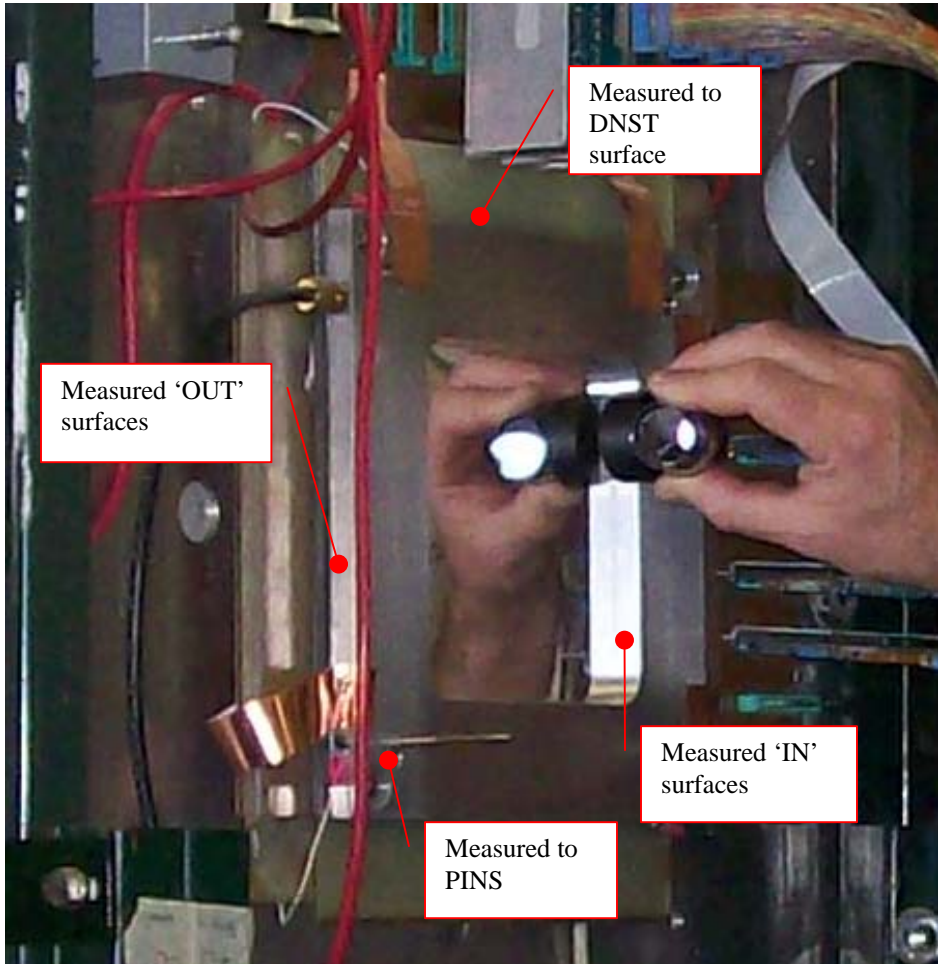

PWC1B DOWNSTREAM

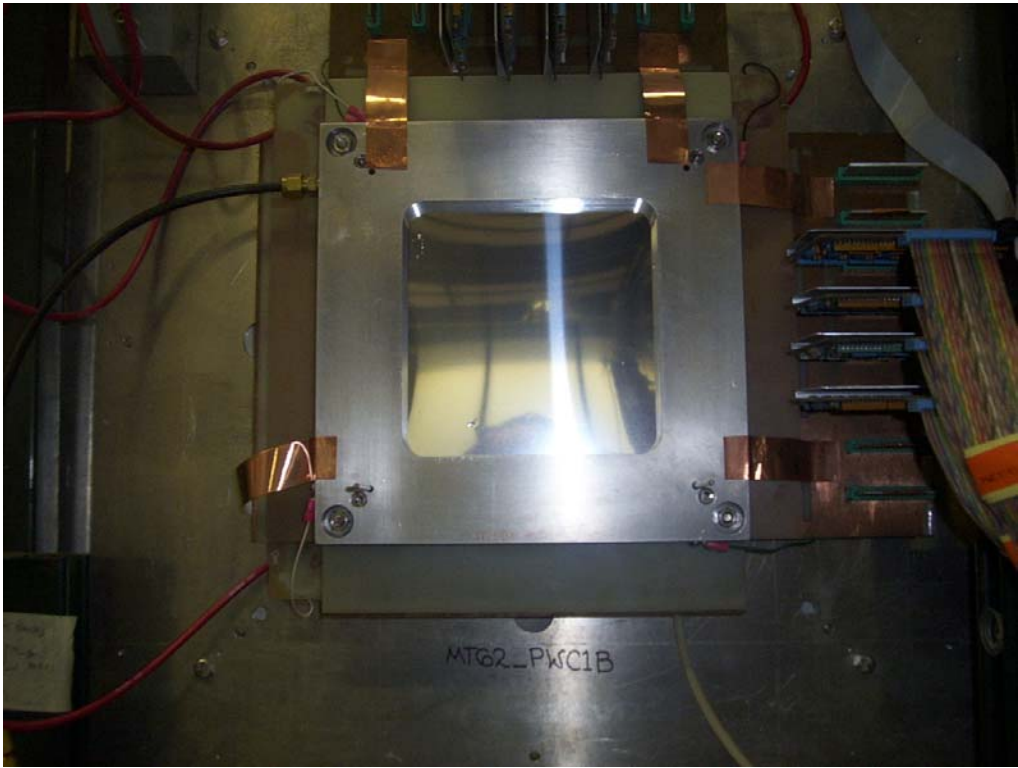

PWC1B DOWNSTREAM

Reference is based on "in side" aperture.
 Origin: Centroid of Intersection of Lines /Points
 [Top, Bottom, Beam right, Beam left]
 Normal Vector of Downstream Plane
 Vector passing thru Top of chamber

MT62_PWC1B REFERENCE VALUES						
Point Name	X	Y	Z	X	Y	Z
	[Inches]	[Inches]	[Inches]	[Metres]	[Metres]	[Metres]
MT62_PWC1B_INNER_APTR_CT	0.000	0.000	0.000	0.00000	0.00000	0.00000
MT62_PWC1B_INNER_TOP_BEAM_RIGHT	3.005	0.001	3.012	0.07633	0.00002	0.07651
MT62_PWC1B_INNER_TOP_BEAM_LEFT	-3.006	-0.001	3.006	-0.07636	-0.00002	0.07634
MT62_PWC1B_INNER_BOTTOM_BEAM_LEFT	-3.004	0.002	-3.012	-0.07630	0.00004	-0.07650
MT62_PWC1B_INNER_BOTTOM_BEAM_RIGHT	3.005	-0.002	-3.006	0.07633	-0.00005	-0.07635
MT62_PWC1B_BOTTOM_BEAM_RIGHT_PIN	3.763	-0.004	-3.736	0.09558	-0.00010	-0.09491
MT62_PWC1B_BOTTOM_BEAM_LEFT_PIN	-3.748	-0.005	-3.747	-0.09521	-0.00013	-0.09517

As-sets are shown relative to the Ideal Beam Sheet Position (Site coordinates for beam line: MTEST_r8.ces)

NOTE: THIS COMPONENT DOES NOT APPEAR ON THE BEAM SHEET – THEREFORE IGNORE THE Y VALUES FOR THE AS-SET LOCAL

MT62_PWC1B ACTUALS AS-SET LOCAL						
Point Name	X	Y	Z	X	Y	Z
	[Inches]	[Inches]	[Inches]	[Metres]	[Metres]	[Metres]
MT62_PWC1B_INNER_APTR_CT	0.000	0.002	-0.064	0.00000	0.00005	-0.00162
MT62_PWC1B_INNER_TOP_BEAM_RIGHT	2.998	-0.089	2.954	0.07615	-0.00226	0.07504
MT62_PWC1B_INNER_TOP_BEAM_LEFT	-3.013	-0.044	2.934	-0.07654	-0.00112	0.07454
MT62_PWC1B_INNER_BOTTOM_BEAM_LEFT	-2.997	0.096	-3.081	-0.07611	0.00243	-0.07826
MT62_PWC1B_INNER_BOTTOM_BEAM_RIGHT	3.012	0.046	-3.063	0.07651	0.00116	-0.07779
MT62_PWC1B_BOTTOM_BEAM_RIGHT_PIN	3.772	0.055	-3.791	0.09580	0.00139	-0.09629
MT62_PWC1B_BOTTOM_BEAM_LEFT_PIN	-3.739	0.111	-3.818	-0.09498	0.00283	-0.09697

MT62_PWC1B ACTUALS AS-SET FSCS(Z)			
Point Name	X	Y	Z
	[Metres]	[Metres]	[Metres]
MT62_PWC1B_INNER_APTR_CT	30248.155609	32199.482459	227.563028
MT62_PWC1B_INNER_TOP_BEAM_RIGHT	30248.230666	32199.495541	227.639678
MT62_PWC1B_INNER_TOP_BEAM_LEFT	30248.080961	32199.465505	227.639180
MT62_PWC1B_INNER_BOTTOM_BEAM_LEFT	30248.080570	32199.469450	227.486393
MT62_PWC1B_INNER_BOTTOM_BEAM_RIGHT	30248.230242	32199.499341	227.486863
MT62_PWC1B_BOTTOM_BEAM_RIGHT_PIN	30248.249072	32199.503545	227.468357
MT62_PWC1B_BOTTOM_BEAM_LEFT_PIN	30248.062012	32199.466037	227.467682

NOTES: Coordinates for the device are in the FSCS(z) coordinate system.

(+X - axis) is East, (+Y - axis) is North, (+Z - axis) is Vertical elevation

+ve Roll is cw rotation about the +Y-axis

+ve Pitch is the Vertical angle above the X-Y plane

+ve Yaw is the cw rotation about the +ve Z-axis

MT6 SECTION 2 PWC2A

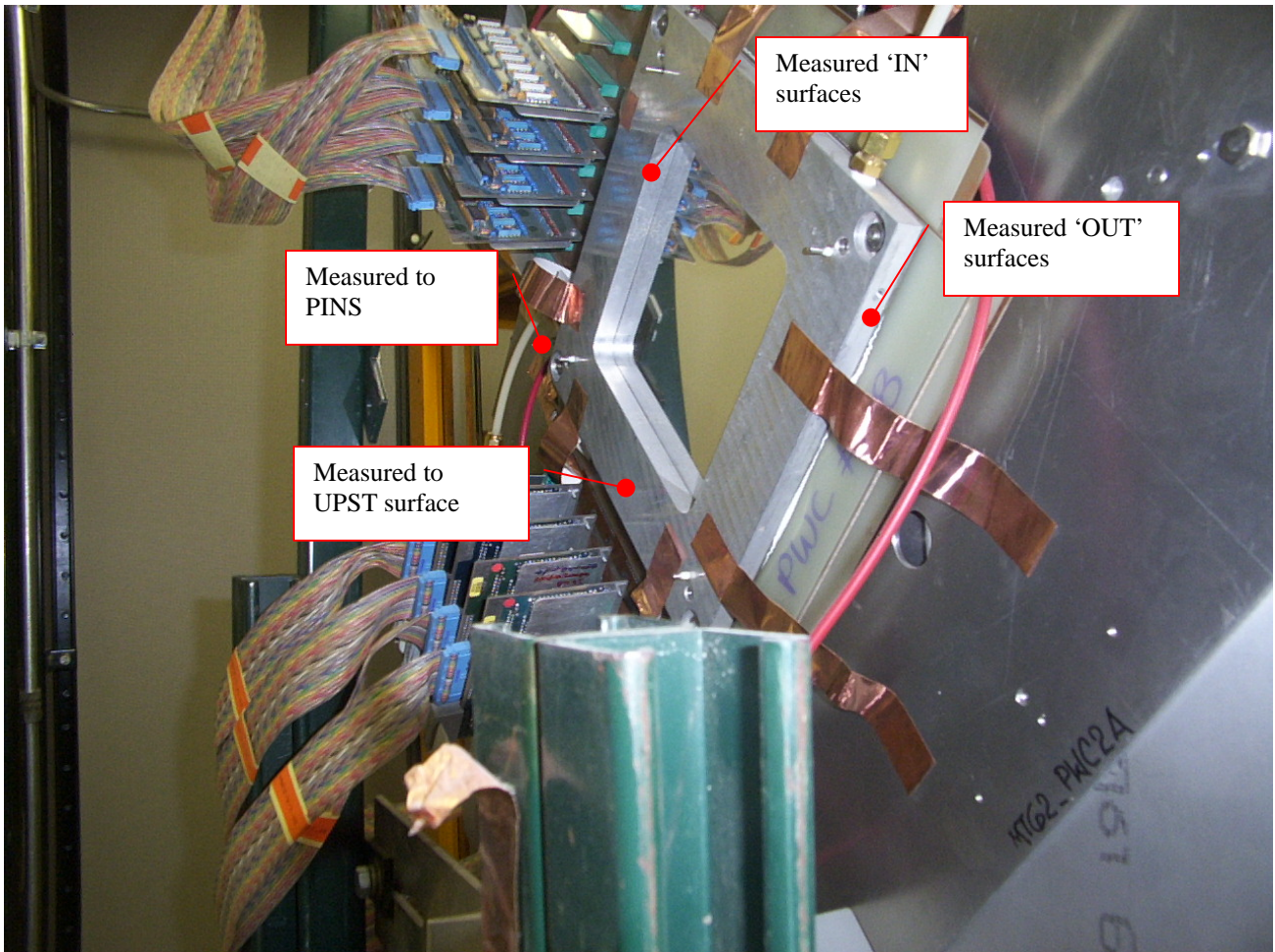
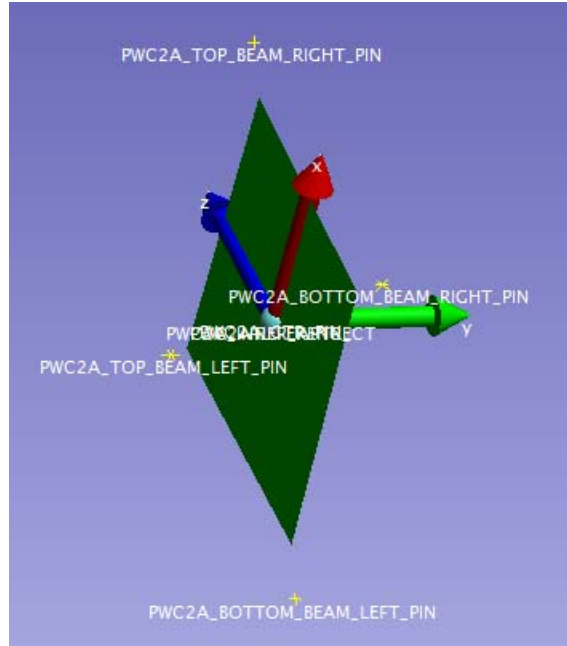

PWC2A UPSTREAM (Beam Right View)

Reference is based on Best-fit Transformation to nominal pin values.

MT62_PWC2A REFERENCE VALUES						
Point Name	X	Y	Z	X	Y	Z
	[Inches]	[Inches]	[Inches]	[Metres]	[Metres]	[Metres]
PWC2A_INNER_TOP_BEAM_RIGHT	3.010	-0.008	2.988	0.07646	-0.00021	0.07590
PWC2A_INNER_BOTTOM_BEAM_LEFT	-3.004	-0.010	-3.018	-0.07630	-0.00026	-0.07667
PWC2A_INNER_TOP_BEAM_LEFT	-2.999	-0.009	2.994	-0.07616	-0.00022	0.07605
PWC2A_INNER_BOTTOM_BEAM_RIGHT	3.005	-0.011	-3.014	0.07632	-0.00027	-0.07655
PWC2A_OUTER_TOP_BEAM_RIGHT	5.011	0.004	4.986	0.12729	0.00011	0.12664
PWC2A_OUTER_BOTTOM_BEAM_LEFT	-4.996	-0.006	-5.013	-0.12690	-0.00016	-0.12732
PWC2A_OUTER_TOP_BEAM_LEFT	-4.986	-0.001	4.997	-0.12665	-0.00003	0.12693
PWC2A_OUTER_BOTTOM_BEAM_RIGHT	4.998	0.004	-5.025	0.12696	0.00010	-0.12764
PWC2A_INNER_APTR_CT	0.003	-0.009	-0.012	0.00008	-0.00024	-0.00032
PWC2A_OUTER_APTR_CT	0.007	0.000	-0.014	0.00017	0.00001	-0.00035
PWC2A_TOP_BEAM_RIGHT_PIN	3.745	-0.001	3.745	0.09512	-0.00003	0.09513
PWC2A_BOTTOM_BEAM_RIGHT_PIN	3.763	0.001	-3.747	0.09558	0.00003	-0.09517
PWC2A_BOTTOM_BEAM_LEFT_PIN	-3.752	-0.001	-3.752	-0.09531	-0.00003	-0.09531
PWC2A_TOP_BEAM_LEFT_PIN	-3.754	0.001	3.754	-0.09536	0.00003	0.09535
PWC2A_CT_PIN	0.000	0.000	0.000	0.00000	0.00000	0.00000

As-sets are shown relative to the Ideal Beam Sheet Position (Site coordinates for beam line: MTEST_r8.ces)

NOTE: THIS COMPONENT DOES NOT APPEAR ON THE BEAM SHEET – THEREFORE IGNORE THE Y VALUES FOR THE AS-SET LOCAL

MT62_PWC2A ACTUALS AS-SET LOCAL						
Point Name	X	Y	Z	X	Y	Z
	[Inches]	[Inches]	[Inches]	[Metres]	[Metres]	[Metres]
PWC2A_INNER_TOP_BEAM_RIGHT	0.061	0.021	4.337	0.00154	0.00053	0.11017
PWC2A_INNER_BOTTOM_BEAM_LEFT	0.113	-0.039	-4.162	0.00288	-0.00098	-0.10573
PWC2A_INNER_TOP_BEAM_LEFT	-4.162	-0.079	0.064	-0.10573	-0.00200	0.00164
PWC2A_INNER_BOTTOM_BEAM_RIGHT	4.329	0.060	0.118	0.10996	0.00151	0.00300
PWC2A_OUTER_TOP_BEAM_RIGHT	0.044	0.052	7.165	0.00112	0.00132	0.18199
PWC2A_OUTER_BOTTOM_BEAM_LEFT	0.134	-0.053	-6.981	0.00340	-0.00135	-0.17732
PWC2A_OUTER_TOP_BEAM_LEFT	-6.984	-0.118	0.057	-0.17740	-0.00299	0.00144
PWC2A_OUTER_BOTTOM_BEAM_RIGHT	7.161	0.121	0.124	0.18188	0.00308	0.00315
PWC2A_INNER_APTR_CT	0.085	-0.009	0.089	0.00216	-0.00023	0.00227
PWC2A_OUTER_APTR_CT	0.089	0.001	0.091	0.00225	0.00001	0.00231
PWC2A_TOP_BEAM_RIGHT_PIN	0.038	0.035	5.392	0.00096	0.00088	0.13696
PWC2A_BOTTOM_BEAM_RIGHT_PIN	5.383	0.089	0.143	0.13674	0.00226	0.00363
PWC2A_BOTTOM_BEAM_LEFT_PIN	0.110	-0.036	-5.210	0.00279	-0.00093	-0.13235
PWC2A_TOP_BEAM_LEFT_PIN	-5.234	-0.087	0.060	-0.13295	-0.00220	0.00153
PWC2A_CT_PIN	0.074	0.000	0.096	0.00189	0.00000	0.00244

MT62_PWC2A ACTUALS AS-SET FSCS(Z)			
Point Name	X	Y	Z
	[Metres]	[Metres]	[Metres]
PWC2A_INNER_TOP_BEAM_RIGHT	30246.866403	32205.675997	227.690897
PWC2A_INNER_BOTTOM_BEAM_LEFT	30246.867903	32205.675335	227.474999
PWC2A_INNER_TOP_BEAM_LEFT	30246.761848	32205.651914	227.582357
PWC2A_INNER_BOTTOM_BEAM_RIGHT	30246.972283	32205.699352	227.583729
PWC2A_OUTER_TOP_BEAM_RIGHT	30246.865861	32205.676508	227.762714
PWC2A_OUTER_BOTTOM_BEAM_LEFT	30246.868452	32205.675252	227.403405
PWC2A_OUTER_TOP_BEAM_LEFT	30246.691889	32205.636316	227.582154
PWC2A_OUTER_BOTTOM_BEAM_RIGHT	30247.042374	32205.715556	227.583886
PWC2A_INNER_APTR_CT	30246.867110	32205.675650	227.582996
PWC2A_OUTER_APTR_CT	30246.867144	32205.675908	227.583040
PWC2A_TOP_BEAM_RIGHT_PIN	30246.865774	32205.676156	227.717684
PWC2A_BOTTOM_BEAM_RIGHT_PIN	30246.998345	32205.705544	227.584358
PWC2A_BOTTOM_BEAM_LEFT_PIN	30246.867798	32205.675434	227.448378
PWC2A_TOP_BEAM_LEFT_PIN	30246.735236	32205.646159	227.582246
PWC2A_CT_PIN	30246.866788	32205.675823	227.583166

NOTES: Coordinates for the device are in the FSCS(z) coordinate system.

(+X - axis) is East, (+Y - axis) is North, (+Z - axis) is Vertical elevation

+ve Roll is cw rotation about the +Y-axis

+ve Pitch is the Vertical angle above the X-Y plane

+ve Yaw is the cw rotation about the +ve Z-axis

MT6 SECTION 2 PWC2B

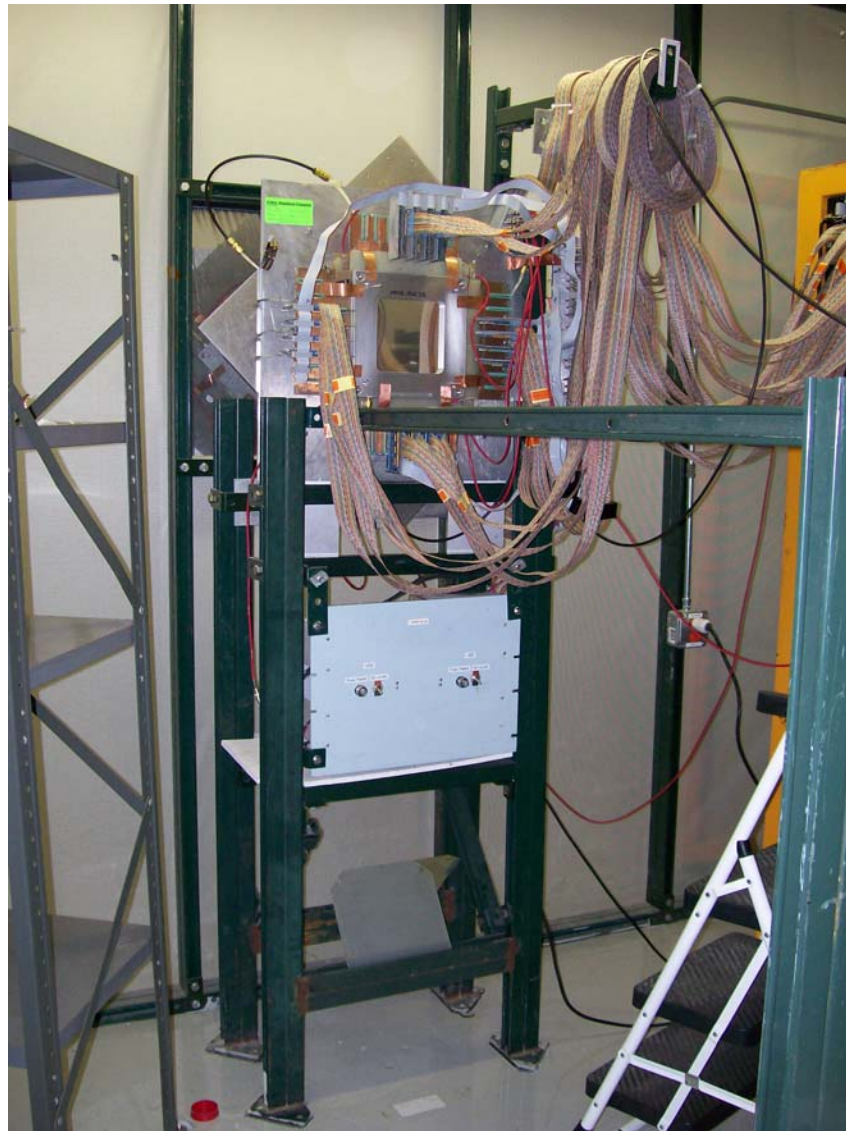
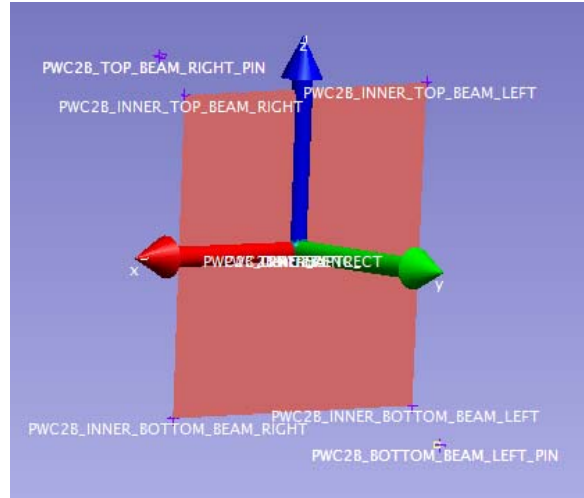

PWC2B DOWNSTREAM (Looking Upstream)

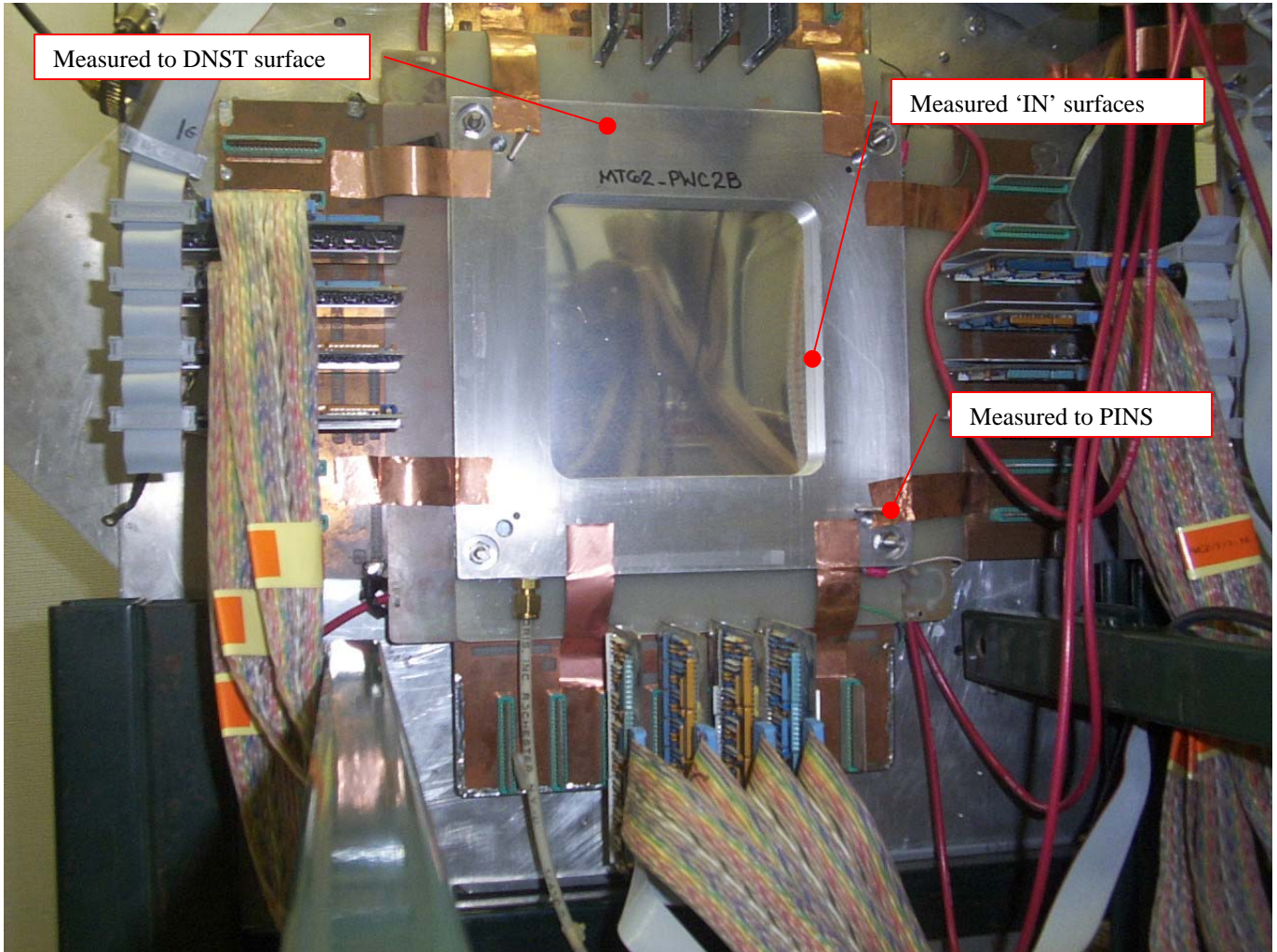

PWC2B DOWNSTREAM (Looking Upstream)

Reference is based on "in side" aperture.
 Origin: Centroid of Intersection of Lines /Points
 [Top, Bottom, Beam right, Beam left]
 Normal Vector of Downstream Plane
 Vector passing thru Top of chamber

MT62_PWC2B REFERENCE VALUES						
Point Name	X	Y	Z	X	Y	Z
	[Inches]	[Inches]	[Inches]	[Metres]	[Metres]	[Metres]
MT62_PWC2B_INNER_TOP_BEAM_RIGHT	3.008	-0.002	2.999	0.07640	-0.00004	0.07616
MT62_PWC2B_INNER_TOP_BEAM_LEFT	-3.013	0.002	2.997	-0.07652	0.00004	0.07612
MT62_PWC2B_INNER_BOTTOM_BEAM_RIGHT	3.008	0.002	-2.991	0.07640	0.00006	-0.07596
MT62_PWC2B_INNER_BOTTOM_BEAM_LEFT	-3.003	-0.002	-3.005	-0.07627	-0.00006	-0.07632
MT62_PWC2B_INNER_APTR_CT	0.000	0.000	0.000	0.00000	0.00000	0.00000
MT62_PWC2B_TOP_BEAM_RIGHT_PIN	3.736	0.003	3.753	0.09491	0.00009	0.09534
MT62_PWC2B_BOTTOM_BEAM_LEFT_PIN	-3.760	0.002	-3.763	-0.09551	0.00004	-0.09557

As-sets are shown relative to the Ideal Beam Sheet Position (Site coordinates for beam line: MTEST_r8.ces)

NOTE: THIS COMPONENT DOES NOT APPEAR ON THE BEAM SHEET – THEREFORE IGNORE THE Y VALUES FOR THE AS-SET LOCAL

MT62_PWC2B ACTUALS AS-SET LOCAL						
Point Name	X	Y	Z	X	Y	Z
	[Inches]	[Inches]	[Inches]	[Metres]	[Metres]	[Metres]
MT62_PWC2B_INNER_TOP_BEAM_RIGHT	2.999	0.085	2.990	0.07617	0.00216	0.07595
MT62_PWC2B_INNER_TOP_BEAM_LEFT	-3.021	-0.006	3.006	-0.07673	-0.00016	0.07635
MT62_PWC2B_INNER_BOTTOM_BEAM_RIGHT	2.982	0.010	-2.999	0.07575	0.00026	-0.07616
MT62_PWC2B_INNER_BOTTOM_BEAM_LEFT	-3.027	-0.089	-2.995	-0.07690	-0.00226	-0.07607
MT62_PWC2B_INNER_APTR_CT	-0.017	0.000	0.001	-0.00043	0.00000	0.00002
MT62_PWC2B_TOP_BEAM_RIGHT_PIN	3.729	0.111	3.743	0.09473	0.00283	0.09506
MT62_PWC2B_BOTTOM_BEAM_LEFT_PIN	-3.787	-0.107	-3.751	-0.09618	-0.00271	-0.09526

MT62_PWC2B ACTUALS AS-SET FSCS(Z)			
Point Name	X	Y	Z
	[Metres]	[Metres]	[Metres]
MT62_PWC2B_INNER_TOP_BEAM_RIGHT	30246.913976	32205.813495	227.656995
MT62_PWC2B_INNER_TOP_BEAM_LEFT	30246.764764	32205.780025	227.657392
MT62_PWC2B_INNER_BOTTOM_BEAM_RIGHT	30246.913875	32205.811926	227.504876
MT62_PWC2B_INNER_BOTTOM_BEAM_LEFT	30246.764952	32205.778314	227.504962
MT62_PWC2B_INNER_APTR_CT	30246.839392	32205.795940	227.581056
MT62_PWC2B_TOP_BEAM_RIGHT_PIN	30246.932016	32205.817889	227.676109
MT62_PWC2B_BOTTOM_BEAM_LEFT_PIN	30246.746154	32205.773984	227.485768

NOTES: Coordinates for the device are in the FSCS(z) coordinate system.

(+X - axis) is East, (+Y - axis) is North, (+Z – axis) is Vertical elevation

+ve Roll is cw rotation about the +Y-axis

+ve Pitch is the Vertical angle above the X-Y plane

+ve Yaw is the cw rotation about the +ve Z-axis

MT6 SECTION 2 PWC3A

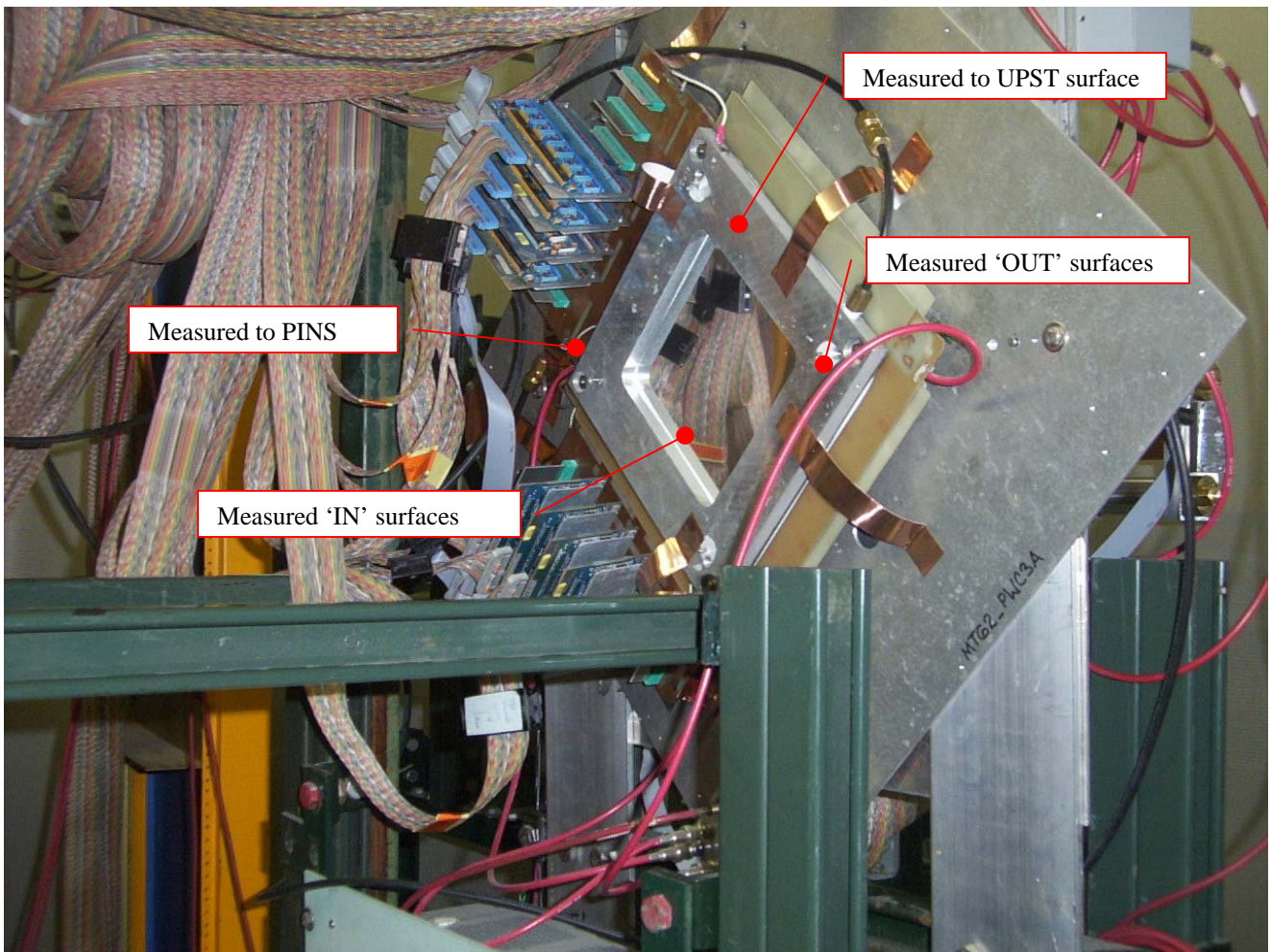
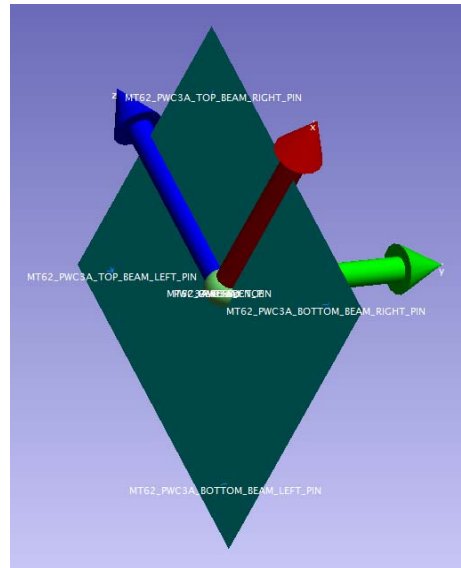

PWC3A UPSTREAM (Looking from Beam Right)

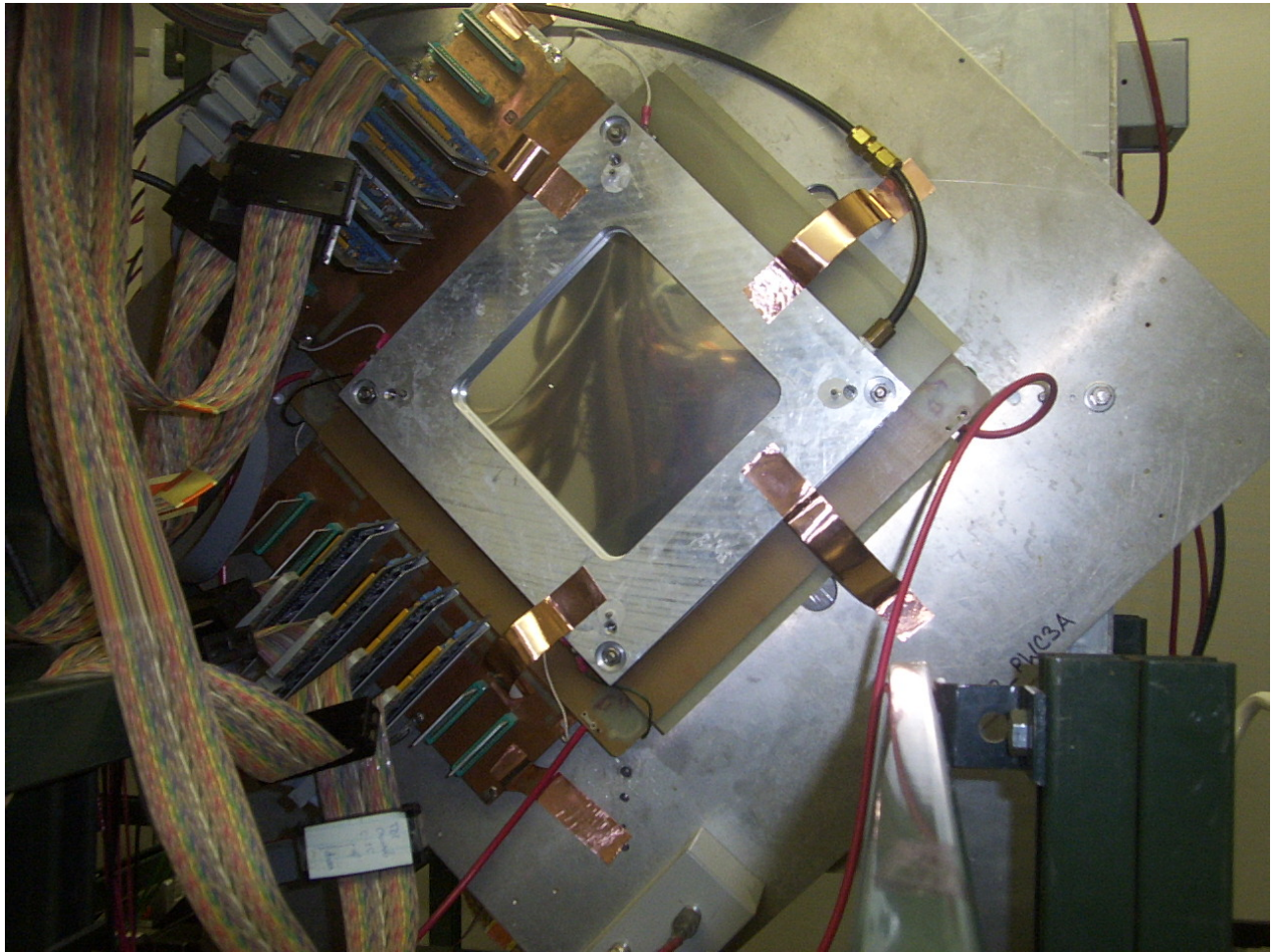

PWC3A UPSTREAM (Looking Downstream)

Reference is based on Best-fit Transformation to nominal pin values.

MT62_PWC3A REFERENCE VALUES						
Point Name	X	Y	Z	X	Y	Z
	[Inches]	[Inches]	[Inches]	[Metres]	[Metres]	[Metres]
MT62_PWC3A_INNER_TOP_BEAM_RIGHT	3.015	-0.004	3.002	0.07659	-0.00010	0.07625
MT62_PWC3A_INNER_TOP_BEAM_LEFT	-2.997	-0.001	2.994	-0.07613	-0.00001	0.07605
MT62_PWC3A_INNER_BOTTOM_BEAM_RIGHT	2.997	-0.001	-3.005	0.07611	-0.00002	-0.07633
MT62_PWC3A_INNER_BOTTOM_BEAM_LEFT	-2.994	0.003	-3.006	-0.07604	0.00007	-0.07635
MT62_PWC3A_OUTER_TOP_BEAM_RIGHT	5.001	-0.001	4.998	0.12703	-0.00002	0.12696
MT62_PWC3A_OUTER_TOP_BEAM_LEFT	-5.007	0.001	4.998	-0.12717	0.00004	0.12695
MT62_PWC3A_OUTER_BOTTOM_BEAM_LEFT	-4.995	0.003	-5.002	-0.12688	0.00006	-0.12706
MT62_PWC3A_OUTER_BOTTOM_BEAM_RIGHT	5.014	0.002	-5.006	0.12736	0.00006	-0.12715
MT62_PWC3A_TOP_BEAM_RIGHT_PIN	3.754	0.000	3.751	0.09535	0.00000	0.09528
MT62_PWC3A_BOTTOM_BEAM_LEFT_PIN	-3.754	0.000	-3.748	-0.09535	0.00000	-0.09519
MT62_PWC3A_TOP_BEAM_LEFT_PIN	-3.749	-0.000	3.743	-0.09522	-0.00000	0.09507
MT62_PWC3A_BOTTOM_BEAM_RIGHT_PIN	3.749	-0.000	-3.746	0.09522	-0.00000	-0.09516
MT62_PWCA_OUTER_APTR_CT	0.003	0.001	-0.003	0.00008	0.00004	-0.00008
MT62_PWCA_INNER_APTR_CT	0.005	-0.001	-0.004	0.00013	-0.00002	-0.00009
MT62_PWC3A_CT_PIN	-0.000	-0.000	-0.000	-0.00000	-0.00000	-0.00000

As-sets are shown relative to the Ideal Beam Sheet Position (Site coordinates for beam line: MTEST_r8.ces)

NOTE: THIS COMPONENT DOES NOT APPEAR ON THE BEAM SHEET – THEREFORE IGNORE THE Y VALUES FOR THE AS-SET LOCAL

MT62_PWC3A ACTUALS AS-SET LOCAL						
Point Name	X	Y	Z	X	Y	Z
	[Inches]	[Inches]	[Inches]	[Metres]	[Metres]	[Metres]
MT62_PWC3A_INNER_TOP_BEAM_RIGHT	0.108	-0.105	4.050	0.00274	-0.00267	0.10286
MT62_PWC3A_INNER_TOP_BEAM_LEFT	-4.128	-0.064	-0.217	-0.10486	-0.00163	-0.00551
MT62_PWC3A_INNER_BOTTOM_BEAM_RIGHT	4.351	0.063	-0.199	0.11052	0.00160	-0.00507
MT62_PWC3A_INNER_BOTTOM_BEAM_LEFT	0.125	0.104	-4.445	0.00318	0.00264	-0.11291
MT62_PWC3A_OUTER_TOP_BEAM_RIGHT	0.094	-0.169	6.864	0.00239	-0.00429	0.17436
MT62_PWC3A_OUTER_TOP_BEAM_LEFT	-6.966	-0.105	-0.228	-0.17693	-0.00266	-0.00579
MT62_PWC3A_OUTER_BOTTOM_BEAM_LEFT	0.128	0.171	-7.271	0.00325	0.00434	-0.18469
MT62_PWC3A_OUTER_BOTTOM_BEAM_RIGHT	7.192	0.109	-0.180	0.18267	0.00276	-0.00458
MT62_PWC3A_TOP_BEAM_RIGHT_PIN	0.098	-0.126	5.101	0.00249	-0.00321	0.12957
MT62_PWC3A_BOTTOM_BEAM_LEFT_PIN	0.115	0.126	-5.507	0.00291	0.00321	-0.13988
MT62_PWC3A_TOP_BEAM_LEFT_PIN	-5.189	-0.079	-0.222	-0.13181	-0.00202	-0.00564
MT62_PWC3A_BOTTOM_BEAM_RIGHT_PIN	5.407	0.080	-0.189	0.13734	0.00202	-0.00480
MT62_PWCA_OUTER_APTR_CT	0.112	0.001	-0.204	0.00284	0.00004	-0.00518
MT62_PWCA_INNER_APTR_CT	0.114	-0.001	-0.203	0.00289	-0.00002	-0.00516
MT62_PWC3A_CT_PIN	0.108	0.000	-0.204	0.00273	0.00000	-0.00519

MT62_PWC3A ACTUALS AS-SET FSCS(Z)			
Point Name	X	Y	Z
	[Metres]	[Metres]	[Metres]
MT62_PWC3A_INNER_TOP_BEAM_RIGHT	30246.490603	32207.485061	227.688279
MT62_PWC3A_INNER_TOP_BEAM_LEFT	30246.384994	32207.464398	227.579912
MT62_PWC3A_INNER_BOTTOM_BEAM_RIGHT	30246.595185	32207.511498	227.580367
MT62_PWC3A_INNER_BOTTOM_BEAM_LEFT	30246.489839	32207.490884	227.472528
MT62_PWC3A_OUTER_TOP_BEAM_RIGHT	30246.490628	32207.483226	227.759775
MT62_PWC3A_OUTER_TOP_BEAM_LEFT	30246.314649	32207.448687	227.579629
MT62_PWC3A_OUTER_BOTTOM_BEAM_LEFT	30246.489520	32207.492743	227.400747
MT62_PWC3A_OUTER_BOTTOM_BEAM_RIGHT	30246.665587	32207.527352	227.580853
MT62_PWC3A_TOP_BEAM_RIGHT_PIN	30246.490478	32207.484417	227.714992
MT62_PWC3A_BOTTOM_BEAM_LEFT_PIN	30246.489448	32207.491453	227.445561
MT62_PWC3A_TOP_BEAM_LEFT_PIN	30246.358696	32207.458518	227.579785
MT62_PWC3A_BOTTOM_BEAM_RIGHT_PIN	30246.621354	32207.517382	227.580637
MT62_PWCA_OUTER_APTR_CT	30246.490096	32207.488002	227.580251
MT62_PWCA_INNER_APTR_CT	30246.490155	32207.487960	227.580271
MT62_PWC3A_CT_PIN	30246.489994	32207.487943	227.580244

NOTES: Coordinates for the device are in the FSCS(z) coordinate system.

(+X - axis) is East, (+Y - axis) is North, (+Z - axis) is Vertical elevation

+ve Roll is cw rotation about the +Y-axis

+ve Pitch is the Vertical angle above the X-Y plane

+ve Yaw is the cw rotation about the +ve Z-axis

MT6 SECTION 2 PWC3B

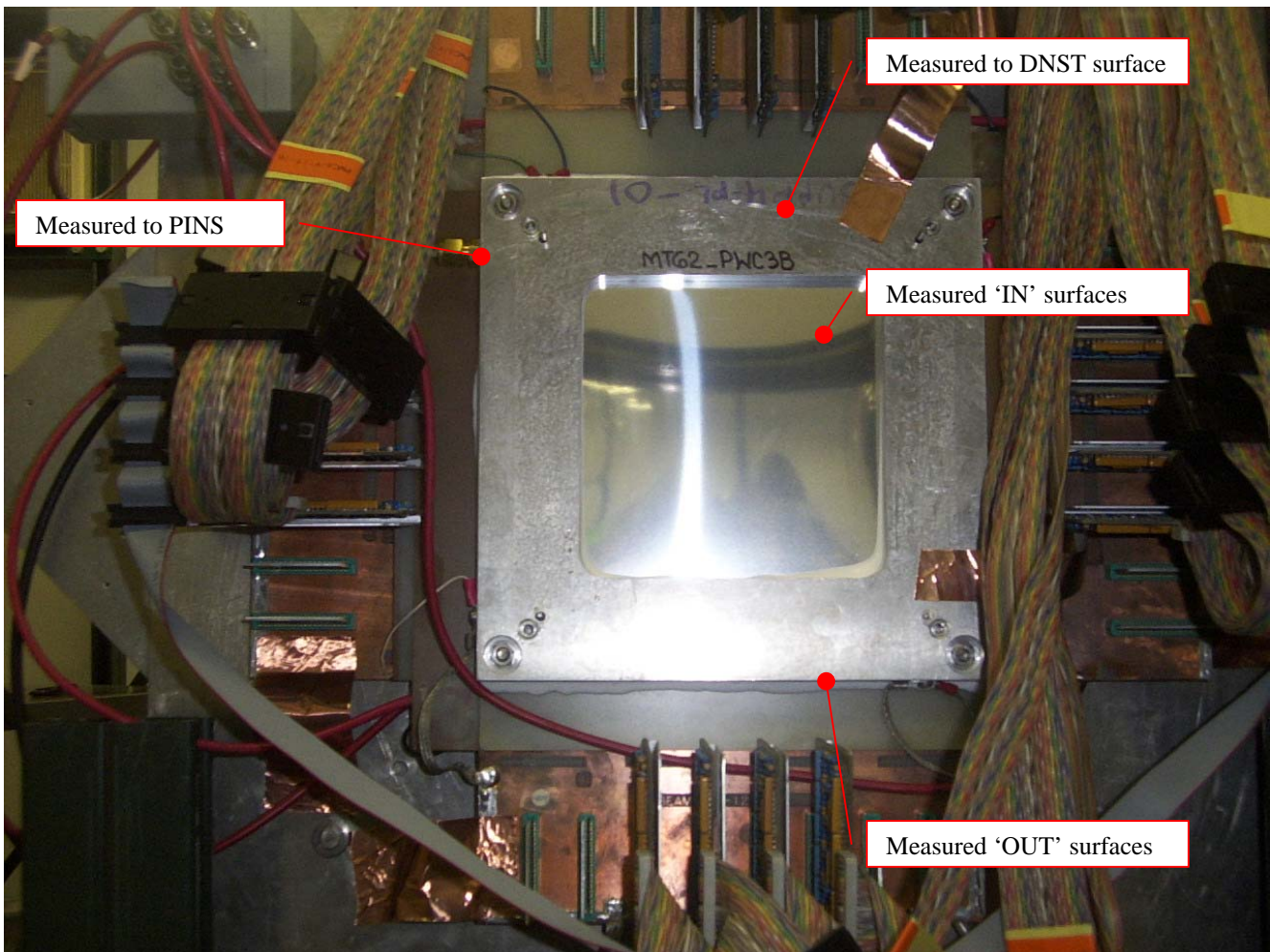
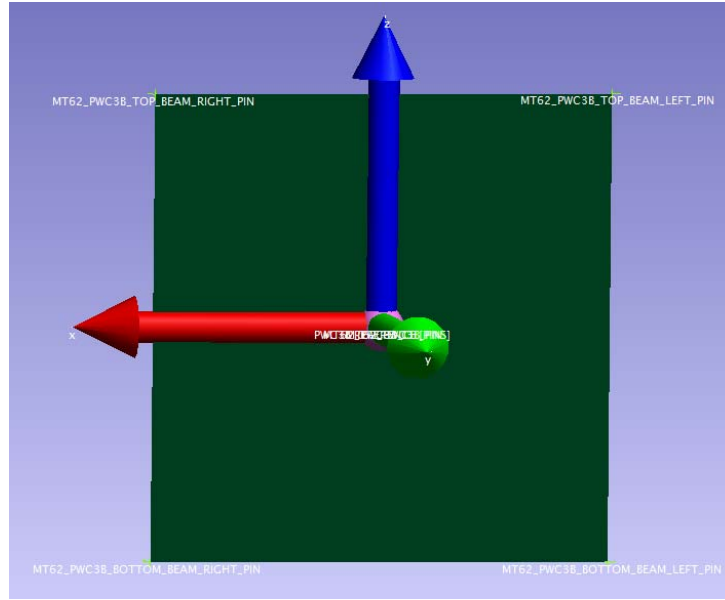

PWC3B DOWNSTREAM (Looking Upstream)



PWC3B DOWNSTREAM (Looking Upstream)

Reference is based on Best-fit Transformation to nominal pin values.

CAUTION: There appears to be an issue with the location of some pins with respect to an expected nominal value of 7.500". Not sure if the problem is with the raw measurements, projection of pins or the fiducials themselves. The angles between the pins are not orthogonal [JCK].

MT62_PWC3B REFERENCE VALUES						
Point Name	X	Y	Z	X	Y	Z
	[Inches]	[Inches]	[Inches]	[Metres]	[Metres]	[Metres]
MT62_PWC3B_INNER_TOP_BEAM_RIGHT	3.007	0.002	3.004	0.07638	0.00006	0.07631
MT62_PWC3B_INNER_TOP_BEAM_LEFT	-2.998	0.010	3.013	-0.07615	0.00027	0.07654
MT62_PWC3B_INNER_BOTTOM_BEAM_LEFT	-2.998	0.004	-3.010	-0.07615	0.00010	-0.07645
MT62_PWC3B_INNER_BOTTOM_BEAM_RIGHT	3.014	0.004	-3.004	0.07655	0.00010	-0.07630
MT62_PWC3B_INNER_APTR_CT	0.006	0.005	0.001	0.00016	0.00013	0.00003
MT62_PWC3B_TOP_BEAM_RIGHT_PIN	3.730	-0.001	3.749	0.09474	-0.00002	0.09523
MT62_PWC3B_TOP_BEAM_LEFT_PIN	-3.746	0.001	3.760	-0.09515	0.00002	0.09550
MT62_PWC3B_BOTTOM_BEAM_LEFT_PIN	-3.739	-0.001	-3.757	-0.09498	-0.00002	-0.09543
MT62_PWC3B_BOTTOM_BEAM_RIGHT_PIN	3.755	0.001	-3.752	0.09538	0.00002	-0.09530
MT62_PWC3B_CT_PIN	-0.000	-0.000	0.000	-0.00000	-0.00000	0.00000

As-sets are shown relative to the Ideal Beam Sheet Position (Site coordinates for beam line: MTEST_r8.ces)

NOTE: THIS COMPONENT DOES NOT APPEAR ON THE BEAM SHEET – THEREFORE IGNORE THE Y VALUES FOR THE AS-SET LOCAL

MT62_PWC3B ACTUALS AS-SET LOCAL						
Point Name	X	Y	Z	X	Y	Z
	[Inches]	[Inches]	[Inches]	[Metres]	[Metres]	[Metres]
MT62_PWC3B_INNER_TOP_BEAM_RIGHT	2.980	-0.046	3.042	0.07569	-0.00117	0.07727
MT62_PWC3B_INNER_TOP_BEAM_LEFT	-3.025	-0.103	2.991	-0.07683	-0.00261	0.07597
MT62_PWC3B_INNER_BOTTOM_BEAM_LEFT	-2.966	0.053	-3.030	-0.07534	0.00134	-0.07696
MT62_PWC3B_INNER_BOTTOM_BEAM_RIGHT	3.045	0.117	-2.964	0.07735	0.00297	-0.07528
MT62_PWC3B_INNER_APTR_CT	0.008	0.005	0.010	0.00021	0.00013	0.00025
MT62_PWC3B_TOP_BEAM_RIGHT_PIN	3.695	-0.062	3.794	0.09386	-0.00156	0.09637
MT62_PWC3B_TOP_BEAM_LEFT_PIN	-3.780	-0.140	3.729	-0.09601	-0.00357	0.09472
MT62_PWC3B_BOTTOM_BEAM_LEFT_PIN	-3.700	0.060	-3.784	-0.09398	0.00152	-0.09612
MT62_PWC3B_BOTTOM_BEAM_RIGHT_PIN	3.794	0.142	-3.704	0.09636	0.00360	-0.09409
MT62_PWC3B_CT_PIN	0.002	0.000	0.009	0.00006	0.00000	0.00022

MT62_PWC3B ACTUALS AS-SET FSCS(Z)			
Point Name	X	Y	Z
	[Metres]	[Metres]	[Metres]
MT62_PWC3B_INNER_TOP_BEAM_RIGHT	30246.537279	32207.618626	227.663000
MT62_PWC3B_INNER_TOP_BEAM_LEFT	30246.388262	32207.586102	227.661700
MT62_PWC3B_INNER_BOTTOM_BEAM_LEFT	30246.388835	32207.590648	227.508776
MT62_PWC3B_INNER_BOTTOM_BEAM_RIGHT	30246.537981	32207.623394	227.510460
MT62_PWC3B_INNER_APTR_CT	30246.463089	32207.604693	227.585984
MT62_PWC3B_TOP_BEAM_RIGHT_PIN	30246.555166	32207.621901	227.682094
MT62_PWC3B_TOP_BEAM_LEFT_PIN	30246.369693	32207.581205	227.680448
MT62_PWC3B_BOTTOM_BEAM_LEFT_PIN	30246.370544	32207.587076	227.489615
MT62_PWC3B_BOTTOM_BEAM_RIGHT_PIN	30246.556453	32207.627941	227.491656
MT62_PWC3B_CT_PIN	30246.462964	32207.604531	227.585953

NOTES: Coordinates for the device are in the FSCS(z) coordinate system.

(+X - axis) is East, (+Y - axis) is North, (+Z - axis) is Vertical elevation

+ve Roll is cw rotation about the +Y-axis

+ve Pitch is the Vertical angle above the X-Y plane

+ve Yaw is the cw rotation about the +ve Z-axis

MT6 SECTION 2 TOF 2

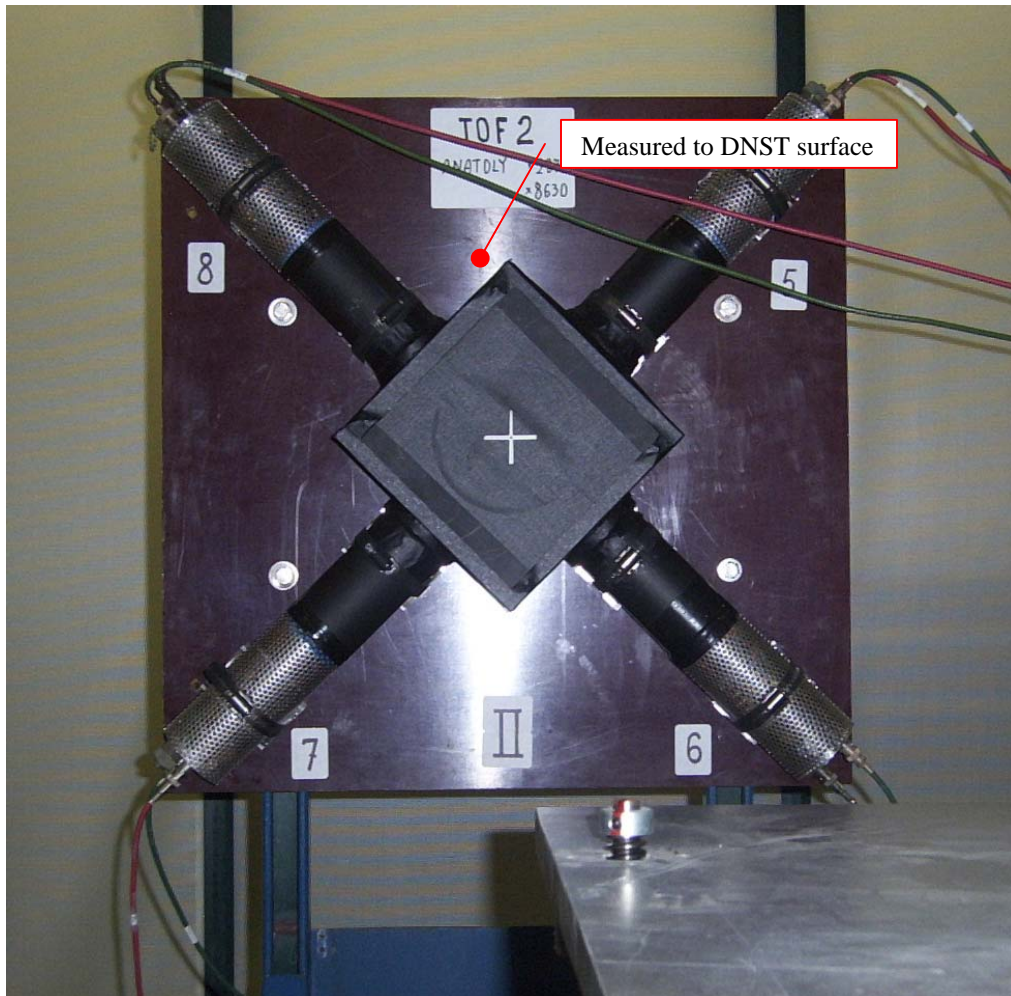
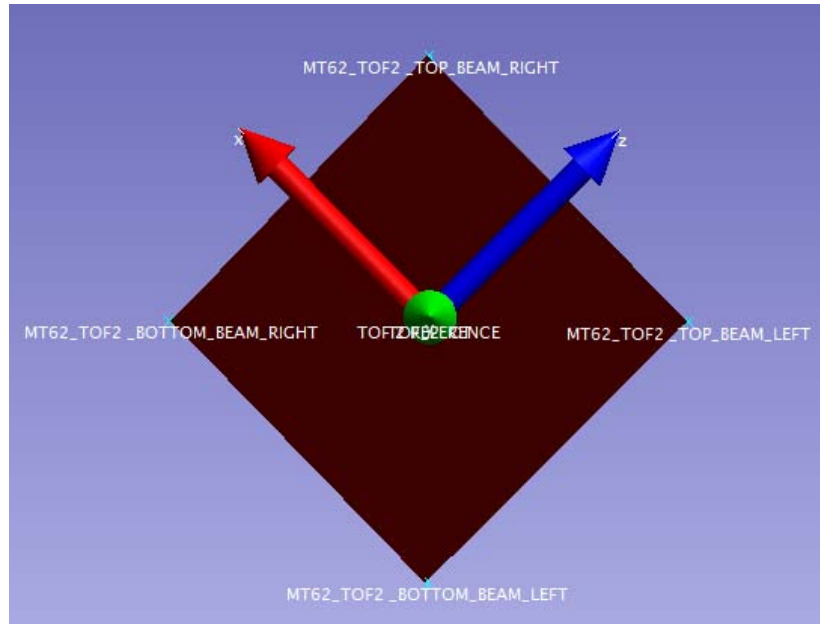

TOF2 DOWNSTREAM (Looking Upstream)

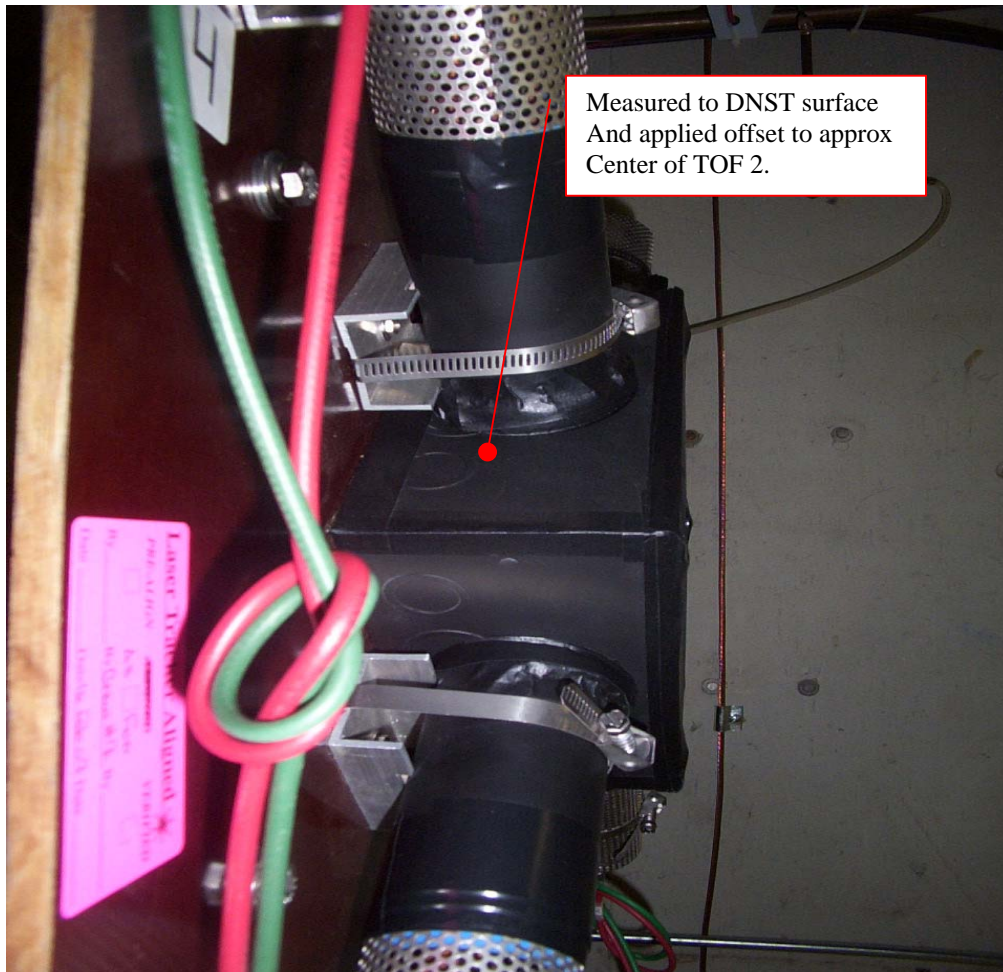

TOF2 BEAM RIGHT VIEW



TOF2 DOWNSTREAM/BEAM RIGHT VIEW (Looking Upstream)

Reference is based on sides of TOF2.
 Origin: Centroid of Intersection of Lines (Translated Upstream 2")
 [Top, Bottom, Beam right, Beam left]
 Normal Vector of Downstream Plane
 Vector passing thru Top of TOF

NOTE: REFERENCE COORDINATE SYSTEM IS ROTATED -45 DEGREES

MT62TOF2 REFERENCE VALUES						
Point Name	X	Y	Z	X	Y	Z
	[Inches]	[Inches]	[Inches]	[Metres]	[Metres]	[Metres]
MT62_TOF2 _TOP_BEAM_RIGHT	4.148	-0.001	4.129	0.10535	-0.00002	0.10487
MT62_TOF2 _BOTTOM_BEAM_LEFT	-4.096	-0.006	-4.117	-0.10404	-0.00014	-0.10456
MT62_TOF2 _BOTTOM_BEAM_RIGHT	4.017	0.007	-4.081	0.10204	0.00018	-0.10366
MT62_TOF2 _TOP_BEAM_LEFT	-4.069	-0.001	4.069	-0.10335	-0.00002	0.10335
MT62_TOF2_CT	0.000	0.000	0.000	0.00000	0.00000	0.00000

As-sets are shown relative to the Ideal Beam Sheet Position (Site coordinates for beam line: MTEST_r8.ces)

NOTE: THIS COMPONENT DOES NOT APPEAR ON THE BEAM SHEET – THEREFORE IGNORE THE Y VALUES FOR THE AS-SET LOCAL

MT62TOF2 ACTUALS AS-SET LOCAL						
Point Name	X	Y	Z	X	Y	Z
	[Inches]	[Inches]	[Inches]	[Metres]	[Metres]	[Metres]
MT62_TOF2 _TOP_BEAM_RIGHT	0.116	0.045	6.103	0.00294	0.00113	0.15502
MT62_TOF2 _BOTTOM_BEAM_LEFT	-0.033	-0.050	-5.555	-0.00083	-0.00128	-0.14110
MT62_TOF2 _BOTTOM_BEAM_RIGHT	5.753	0.022	0.133	0.14611	0.00055	0.00338
MT62_TOF2 _TOP_BEAM_LEFT	-5.726	-0.016	0.326	-0.14545	-0.00041	0.00828
MT62_TOF2_CT	0.027	0.000	0.252	0.00069	0.00000	0.00640

MT62TOF2 ACTUALS AS-SET FSCS (Z)			
Point Name	X	Y	Z
	[Metres]	[Metres]	[Metres]
MT62_TOF2 _TOP_BEAM_RIGHT	30246.007614	32209.803491	227.746458
MT62_TOF2 _BOTTOM_BEAM_LEFT	30246.004259	32209.801094	227.450335
MT62_TOF2 _BOTTOM_BEAM_RIGHT	30246.147815	32209.832508	227.594812
MT62_TOF2 _TOP_BEAM_LEFT	30245.862586	32209.772071	227.599708
MT62_TOF2_CT	30246.005568	32209.802291	227.597828

NOTES: Coordinates for the device are in the FSCS(z) coordinate system.

(+X - axis) is East, (+Y - axis) is North, (+Z - axis) is Vertical elevation

- +ve Roll is cw rotation about the +Y-axis
- +ve Pitch is the Vertical angle above the X-Y plane
- +ve Yaw is the cw rotation about the +ve Z-axis

MT6 SECTION 2 PWC4A (PWC05)

Optical Reference of Chamber PWC05: see e907_pwc_05_reference jck.xls

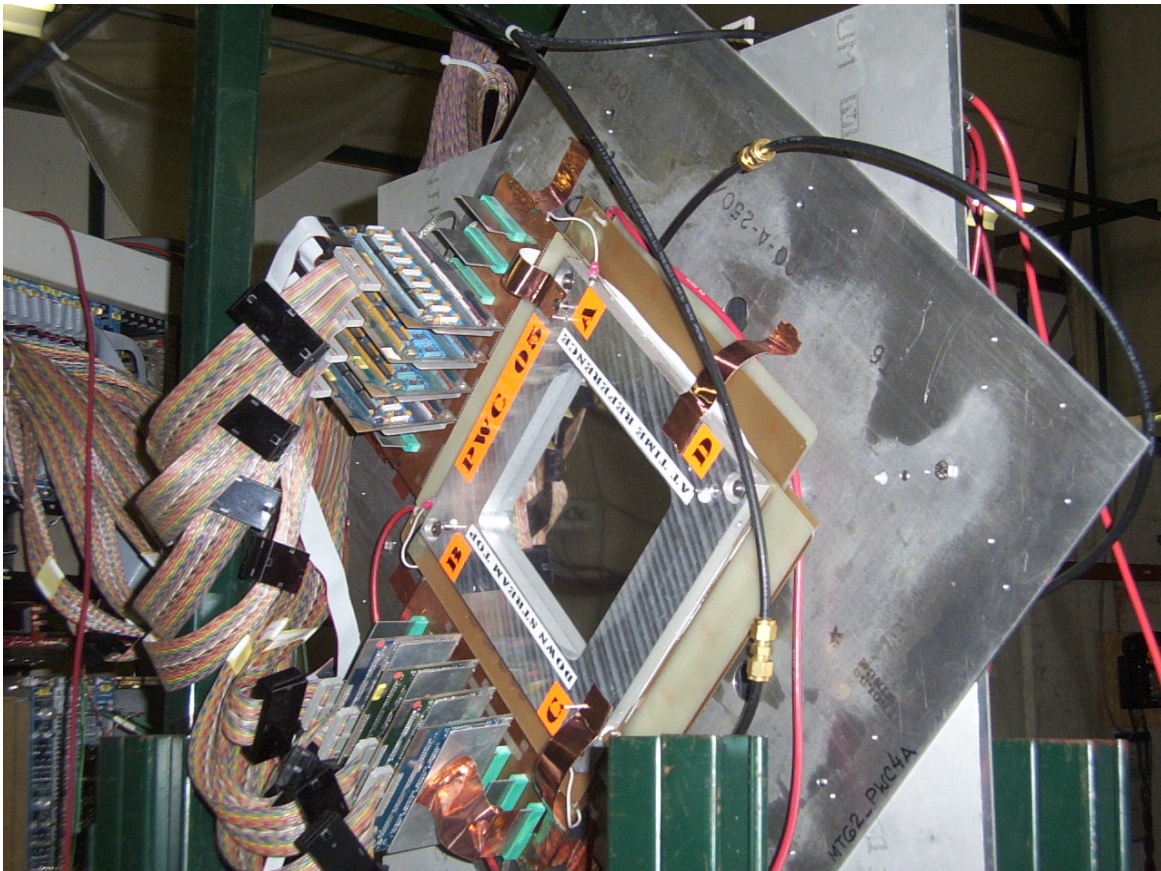
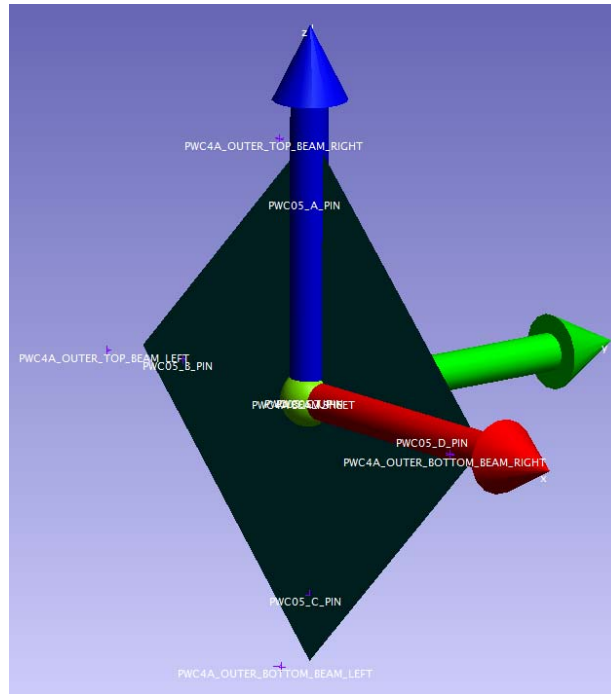

PWC4A (PWC05) UPSTREAM (Looking from Beam Right)

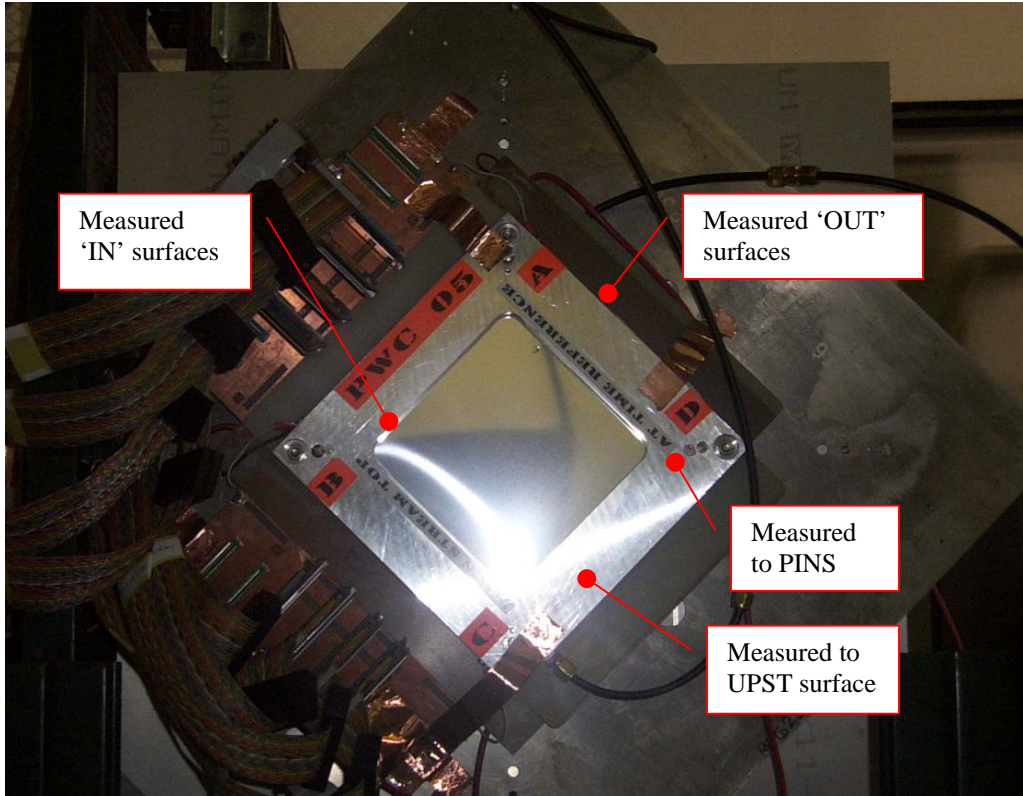

PWC4A (PWC05) UPSTREAM (Looking Downstream)

Note: Chamber is rotated 180 degrees around the 'Z' axis and 45 degrees around the 'Y' axis from the original reference.

Optical Reference of Chamber PWC05: see e907_pwc_05_reference jck.xls

MT62_PWC4A (PWC05) REFERENCE VALUES						
Point Name	X	Y	Z	X	Y	Z
	[Inches]	[Inches]	[Inches]	[Metres]	[Metres]	[Metres]
PWC05_A	-3.755	0.000	-3.744	-0.09538	0.00000	-0.09510
PWC05_B	-3.761	0.000	3.744	-0.09554	0.00000	0.09510
PWC05_C	3.738	0.000	3.761	0.09493	0.00000	0.09554
PWC05_D	3.737	0.000	-3.725	0.09491	0.00000	-0.09462
PWC05_CT	0.000	0.000	0.000	0.00000	0.00000	0.00000

As-sets are shown relative to the Ideal Beam Sheet Position (Site coordinates for beam line: MTEST_r8.ces)

NOTE: THIS COMPONENT DOES NOT APPEAR ON THE BEAM SHEET – THEREFORE IGNORE THE Y VALUES FOR THE AS-SET LOCAL

MT62_PWC4A (PWC05) ACTUALS AS-SET LOCAL						
Point Name	X	Y	Z	X	Y	Z
	[Inches]	[Inches]	[Inches]	[Metres]	[Metres]	[Metres]
PWC05_CT	0.054	-0.005	0.033	0.00136	-0.00013	0.00083
PWC05_A_PIN	0.031	-0.021	5.335	0.00079	-0.00053	0.13552
PWC05_B_PIN	-5.253	-0.002	0.030	-0.13343	-0.00004	0.00076
PWC05_C_PIN	0.052	0.011	-5.270	0.00133	0.00027	-0.13385
PWC05_D_PIN	5.330	-0.009	0.039	0.13539	-0.00022	0.00099

MT62_PWC4A (PWC05) ACTUALS AS-SET FSCS (Z)			
Point Name	X	Y	Z
	[Metres]	[Metres]	[Metres]
PWC05_A	30245.270209	32213.334139	227.601429
PWC05_B	30245.269800	32213.333291	227.736111
PWC05_C	30245.138232	32213.306725	227.601358
PWC05_D	30245.270021	32213.334862	227.466744
PWC05_CT	30245.401430	32213.361394	227.601587

NOTES: Coordinates for the device are in the FSCS(z) coordinate system.

(+X - axis) is East, (+Y - axis) is North, (+Z - axis) is Vertical elevation

+ve Roll is cw rotation about the +Y-axis

+ve Pitch is the Vertical angle above the X-Y plane

+ve Yaw is the cw rotation about the +ve Z-axis

MT6 SECTION 2 PWC4B

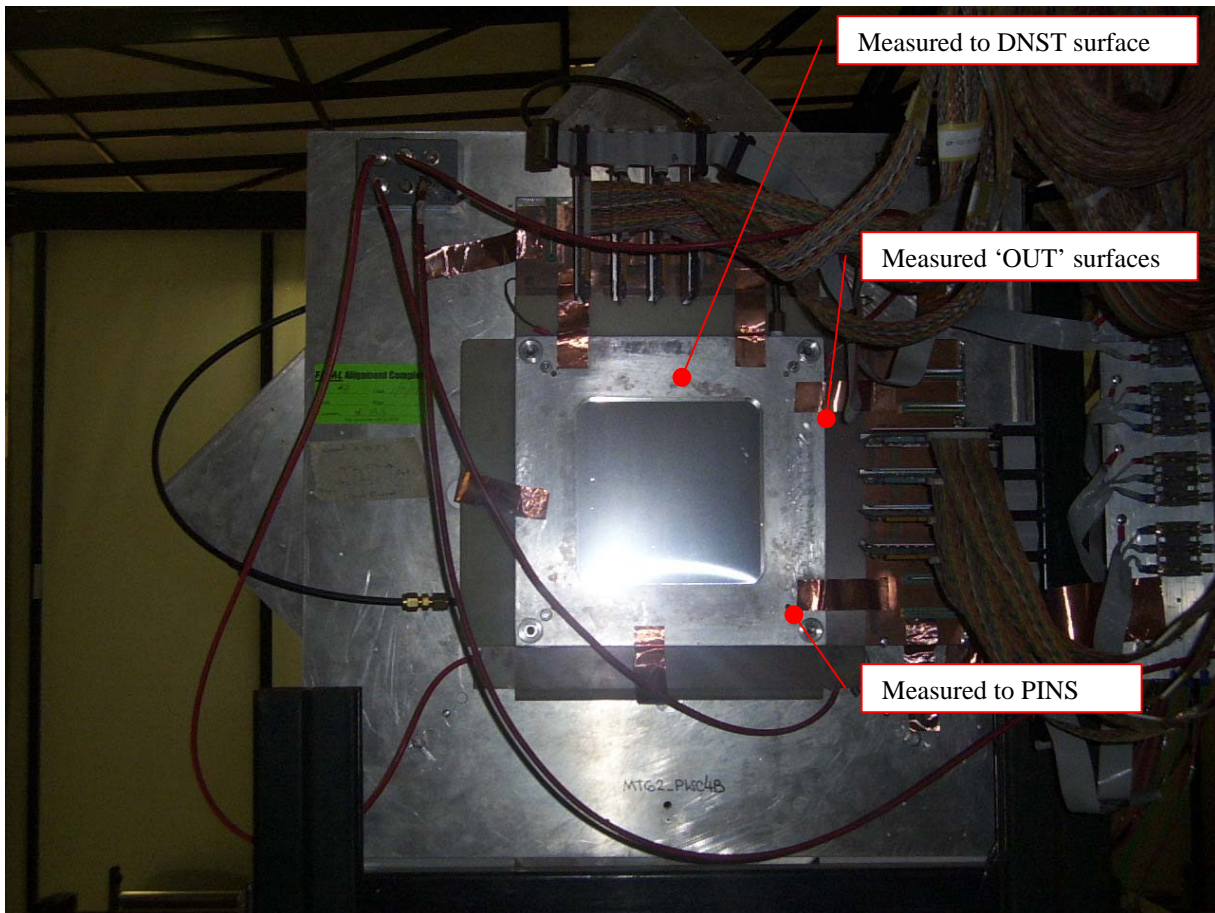
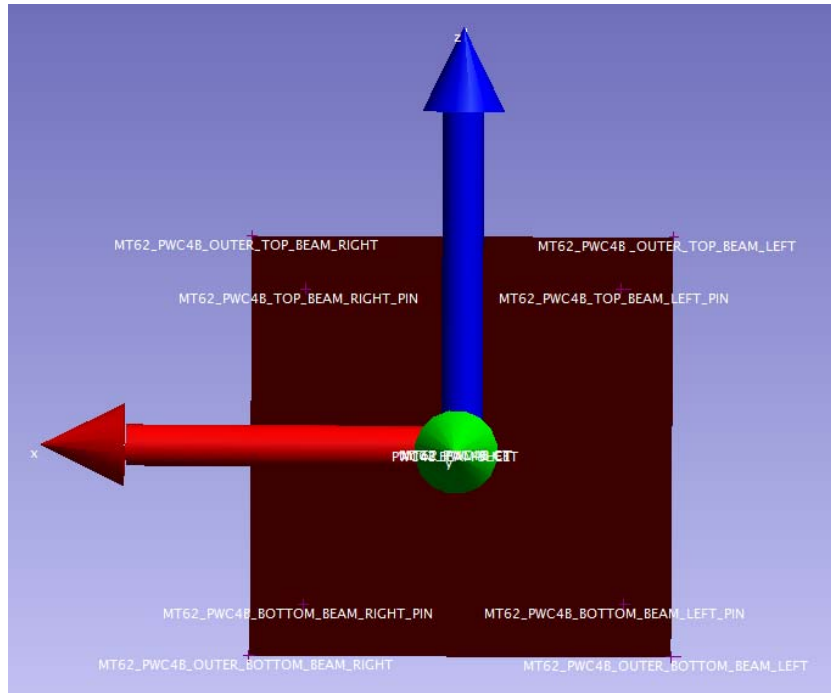

PWC4B DOWNSTREAM (Looking Upstream)

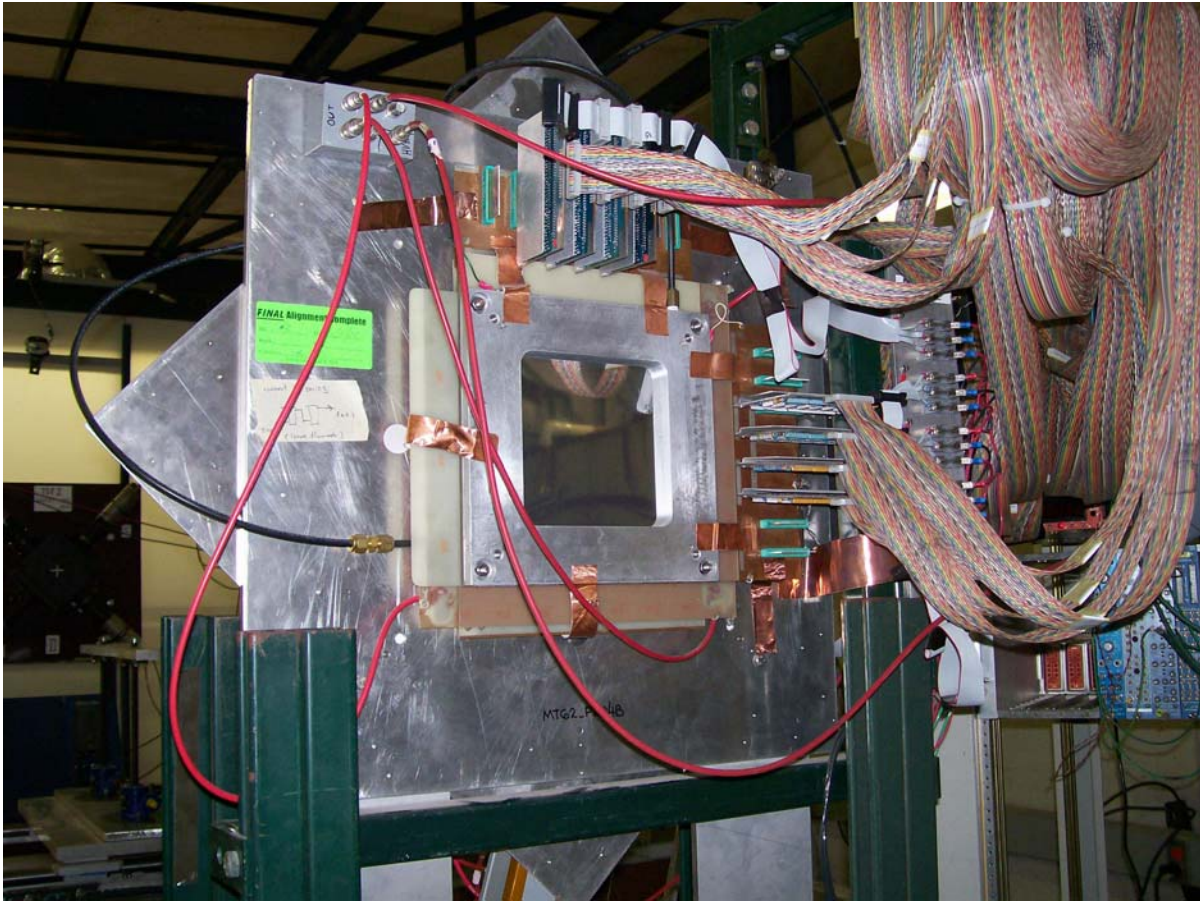

PWC4B DOWNSTREAM (Looking Upstream from Beam Right)

Reference is based on Best-fit Transformation to nominal pin values.

MT62_PWC4B REFERENCE VALUES						
Point Name	X	Y	Z	X	Y	Z
	[Inches]	[Inches]	[Inches]	[Metres]	[Metres]	[Metres]
MT62_PWC4B_CT	-0.000	-0.000	-0.000	0.00000	-0.00000	-0.00000
MT62_PWC4B_BOTTOM_BEAM_LEFT_PIN	-3.756	-0.001	-3.754	-0.09540	-0.00002	-0.09534
MT62_PWC4B_TOP_BEAM_LEFT_PIN	-3.749	0.001	3.761	-0.09522	0.00002	0.09554
MT62_PWC4B_TOP_BEAM_RIGHT_PIN	3.748	-0.001	3.749	0.09521	-0.00002	0.09523
MT62_PWC4B_BOTTOM_BEAM_RIGHT_PIN	3.756	0.001	-3.758	0.09541	0.00002	-0.09545
MT62_PWC4B_OUTER_TOP_BEAM_RIGHT	5.004	-0.012	5.012	0.12710	-0.00029	0.12731
MT62_PWC4B_OUTER_BOTTOM_BEAM_RIGHT	5.018	0.009	-4.997	0.12745	0.00022	-0.12693
MT62_PWC4B_OUTER_BOTTOM_BEAM_LEFT	-4.987	0.022	-5.011	-0.12668	0.00057	-0.12729
MT62_PWC4B_OUTER_TOP_BEAM_LEFT	-5.006	0.008	5.006	-0.12714	0.00021	0.12715

As-sets are shown relative to the Ideal Beam Sheet Position (Site coordinates for beam line: MTEST_r8.ces)

NOTE: THIS COMPONENT DOES NOT APPEAR ON THE BEAM SHEET – THEREFORE IGNORE THE Y VALUES FOR THE AS-SET LOCAL

MT62_PWC4B ACTUALS AS-SET LOCAL						
Point Name	X	Y	Z	X	Y	Z
	[Inches]	[Inches]	[Inches]	[Metres]	[Metres]	[Metres]
MT62_PWC4B_BOTTOM_BEAM_LEFT_PIN	-3.800	-0.013	-3.729	-0.09651	-0.00033	-0.09471
MT62_PWC4B_TOP_BEAM_LEFT_PIN	-3.758	-0.013	3.786	-0.09547	-0.00032	0.09617
MT62_PWC4B_TOP_BEAM_RIGHT_PIN	3.738	0.012	3.740	0.09496	0.00029	0.09500
MT62_PWC4B_BOTTOM_BEAM_RIGHT_PIN	3.712	0.014	-3.767	0.09430	0.00037	-0.09568
MT62_PWC4B_OUTER_TOP_BEAM_RIGHT	5.000	0.005	4.998	0.12699	0.00012	0.12694
MT62_PWC4B_OUTER_BOTTOM_BEAM_RIGHT	4.968	0.027	-5.012	0.12620	0.00069	-0.12730
MT62_PWC4B_OUTER_BOTTOM_BEAM_LEFT	-5.037	0.006	-4.981	-0.12794	0.00015	-0.12652
MT62_PWC4B_OUTER_TOP_BEAM_LEFT	-5.010	-0.010	5.036	-0.12725	-0.00025	0.12793
MT62_PWC4B_CT	-0.027	0.000	0.008	-0.00068	0.00000	0.00020

MT62_PWC4B ACTUALS AS-SET FSCS (Z)			
Point Name	X	Y	Z
	[Metres]	[Metres]	[Metres]
MT62_PWC4B_BOTTOM_BEAM_LEFT_PIN	30245.152457	32213.419396	227.506154
MT62_PWC4B_TOP_BEAM_LEFT_PIN	30245.153576	32213.419136	227.697033
MT62_PWC4B_TOP_BEAM_RIGHT_PIN	30245.339866	32213.458595	227.695867
MT62_PWC4B_BOTTOM_BEAM_RIGHT_PIN	30245.339105	32213.459006	227.505191
MT62_PWC4B_OUTER_TOP_BEAM_RIGHT	30245.371281	32213.464885	227.727803
MT62_PWC4B_OUTER_BOTTOM_BEAM_RIGHT	30245.370255	32213.465907	227.473564
MT62_PWC4B_OUTER_BOTTOM_BEAM_LEFT	30245.121576	32213.413535	227.474348
MT62_PWC4B_OUTER_TOP_BEAM_LEFT	30245.122463	32213.412648	227.728789
MT62_PWC4B_CT	30245.246251	32213.439033	227.601061

NOTES: Coordinates for the device are in the FSCS(z) coordinate system.

(+X - axis) is East, (+Y - axis) is North, (+Z – axis) is Vertical elevation

+ve Roll is cw rotation about the +Y-axis

+ve Pitch is the Vertical angle above the X-Y plane

+ve Yaw is the cw rotation about the +ve Z-axis

MT6 SECTION 2 PWC5A

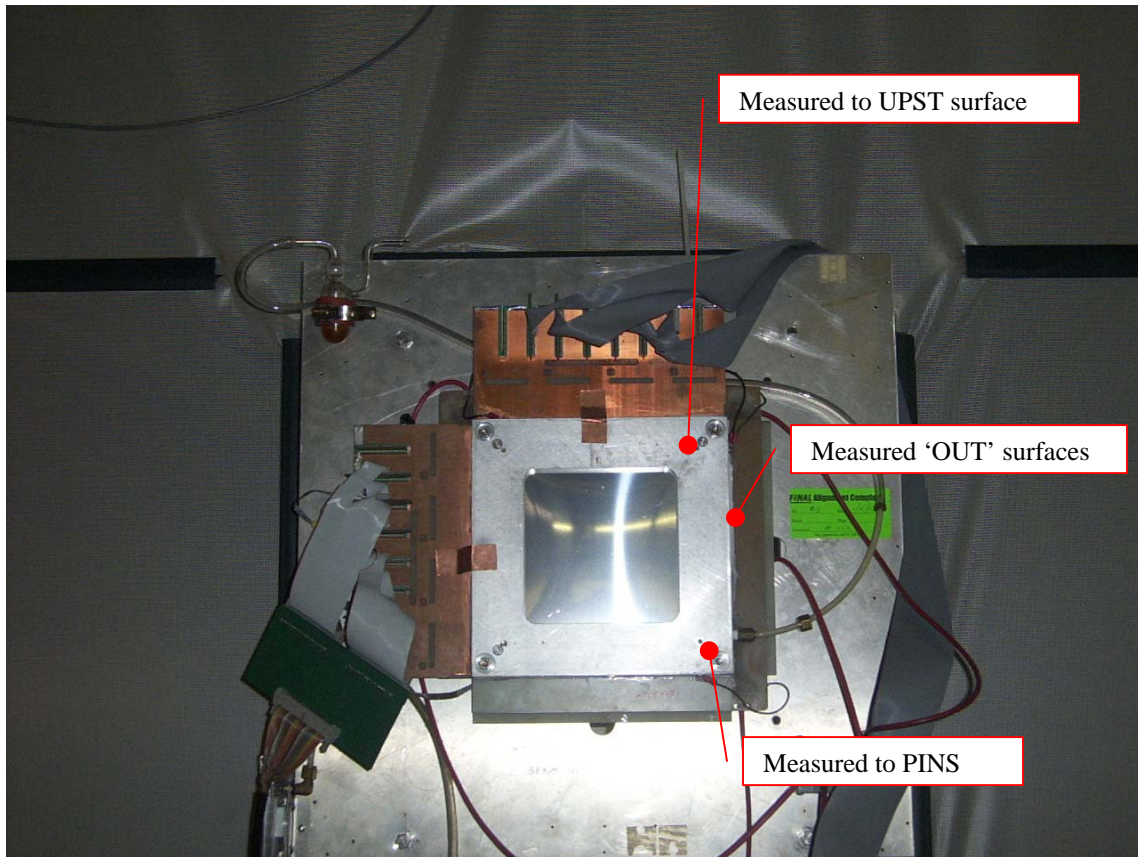
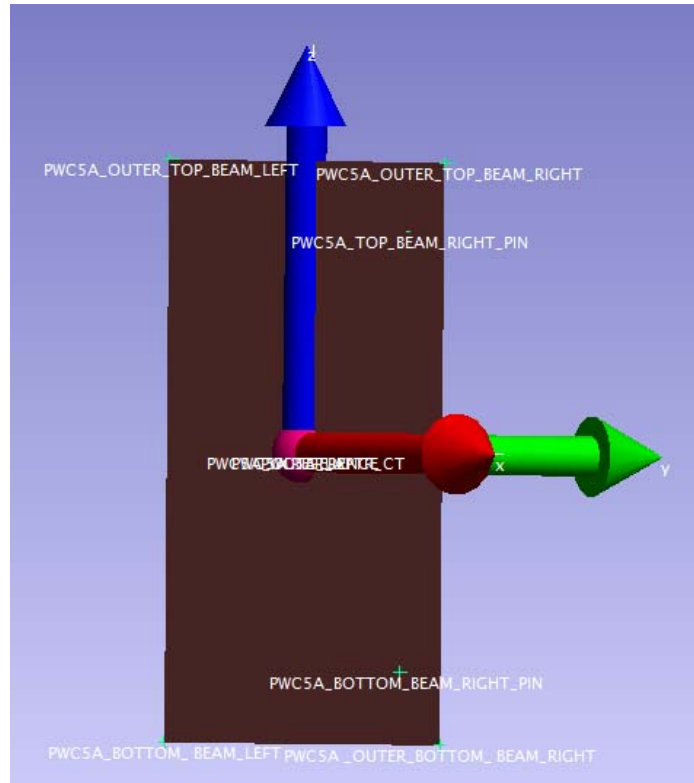

PWC5A UPSTREAM (Looking Downstream)

Reference is based on "outside" aperture.
 Origin: Centroid of Intersection of Lines/Points
 [Top, Bottom, Beam right, Beam left]
 Normal Vector of Upstream Plane
 Vector passing thru Top of chamber

NOTE: NOT ENOUGH DATA TO BASE REFERENCE ON PINS [JCK].

Reference is based on measurements to outer most edges of PWC.

MT62_PWC5A REFERENCE VALUES						
Point Name	X	Y	Z	X	Y	Z
	[Inches]	[Inches]	[Inches]	[Metres]	[Metres]	[Metres]
MT62_PWC5A_OUTER_TOP_BEAM_RIGHT	5.003	0.011	5.003	0.12708	0.00028	0.12706
MT62_PWC5A_OUTER_BOTTOM_BEAM_RIGHT	4.999	-0.011	-5.001	0.12699	-0.00028	-0.12704
MT62_PWC5A_BOTTOM_BEAM_LEFT	-4.999	0.011	-5.005	-0.12699	0.00028	-0.12712
MT62_PWC5A_OUTER_TOP_BEAM_LEFT	-5.003	-0.011	5.004	-0.12708	-0.00028	0.12709
MT62_PWC5A_OUTER_APTR_CT	0.000	0.000	0.000	0.00000	0.00000	0.00000

As-sets are shown relative to the Ideal Beam Sheet Position (Site coordinates for beam line: MTEST_r8.ces)

NOTE: THIS COMPONENT DOES NOT APPEAR ON THE BEAM SHEET – THEREFORE IGNORE THE Y VALUES FOR THE AS-SET LOCAL

MT62_PWC5A ACTUALS AS-SET LOCAL						
Point Name	X	Y	Z	X	Y	Z
	[Inches]	[Inches]	[Inches]	[Metres]	[Metres]	[Metres]
MT62_PWC5A_OUTER_TOP_BEAM_RIGHT	5.053	0.151	4.921	0.12836	0.00384	0.12501
MT62_PWC5A_OUTER_BOTTOM_BEAM_RIGHT	5.015	-0.152	-5.078	0.12738	-0.00387	-0.12898
MT62_PWC5A_BOTTOM_BEAM_LEFT	-4.984	-0.130	-5.047	-0.12659	-0.00329	-0.12819
MT62_PWC5A_OUTER_TOP_BEAM_LEFT	-4.953	0.130	4.958	-0.12580	0.00330	0.12593
MT62_PWC5A_OUTER_APTR_CT	0.033	-0.000	-0.061	0.00084	-0.00000	-0.00156

MT62_PWC5A ACTUALS AS-SET FSCS (Z)			
Point Name	X	Y	Z
	[Metres]	[Metres]	[Metres]
MT62_PWC5A_OUTER_TOP_BEAM_RIGHT	30244.297961	32218.621689	227.739259
MT62_PWC5A_OUTER_BOTTOM_BEAM_RIGHT	30244.298448	32218.614576	227.485257
MT62_PWC5A_BOTTOM_BEAM_LEFT	30244.049702	32218.563321	227.486042
MT62_PWC5A_OUTER_TOP_BEAM_LEFT	30244.049259	32218.569297	227.740181
MT62_PWC5A_OUTER_APTR_CT	30244.173843	32218.592221	227.612685

NOTES: Coordinates for the device are in the FSCS(z) coordinate system.

(+X - axis) is East, (+Y - axis) is North, (+Z - axis) is Vertical elevation

- +ve Roll is cw rotation about the +Y-axis
- +ve Pitch is the Vertical angle above the X-Y plane
- +ve Yaw is the cw rotation about the +ve Z-axis